



ON Semiconductor®

<http://onsemi.com>

# LV52204MT

Bi-CMOS IC

## LED Boost Driver with PWM and 1-Wire Dimming

### Overview

The LV52204MT is a high voltage boost driver for LED drive. LED current is set by the external resistor R1 and LED dimming can be done by changing FB voltage with PWM or 1-Wire.

### Features

- Operating Voltage from 2.7V to 5.5V
- 1-Wire 32 level digital and PWM dimming
- Integrated 40V MOSFET
- 600kHz Switching Frequency

### Typical Applications

- LED Display Backlight Control

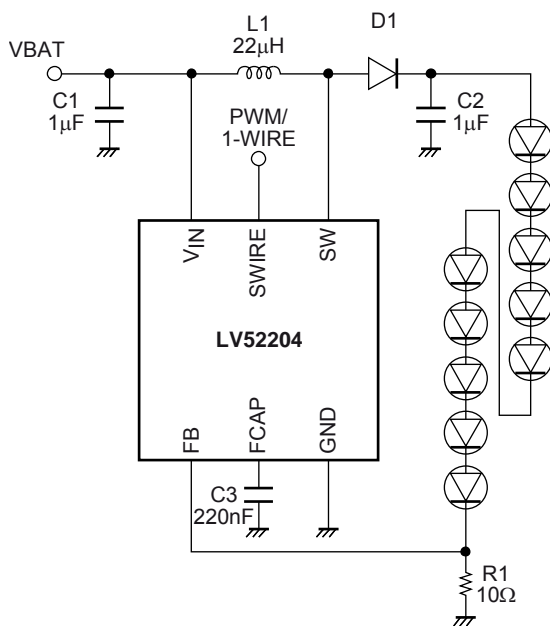

### ORDERING INFORMATION

See detailed ordering and shipping information on page 13 of this data sheet.

# LV52204MT

## Specifications

### Absolute Maximum Ratings at $T_a = 25^\circ\text{C}$

Parameter	Symbol	Conditions	Ratings	Unit
Maximum supply voltage	$V_{CC\text{ max}}$	$V_{CC}$	5.5	V
Maximum pin voltage1	$V1\text{ max}$	SW	40	V
Maximum pin voltage2	$V2\text{ max}$	Other pin	5.5	V
Allowable power dissipation	$Pd\text{ max}$	$T_a = 25^\circ\text{C}^*1$	2.05	W
Operating temperature	$T_{opr}$		-30 to +85	$^\circ\text{C}$
Storage temperature	$T_{stg}$		-55 to +125	$^\circ\text{C}$

\*1 Mounted on a specified board: 70mm×50mm×1.2mm (4 layer glass epoxy)

Caution 1) Absolute maximum ratings represent the values which cannot be exceeded for any length of time.

Caution 2) Even when the device is used within the range of absolute maximum ratings, as a result of continuous usage under high temperature, high current, high voltage, or drastic temperature change, the reliability of the IC may be degraded. Please contact us for the further details.

Stresses exceeding Maximum Ratings may damage the device. Maximum Ratings are stress ratings only. Functional operation above the Recommended Operating Conditions is not implied. Extended exposure to stresses above the Recommended Operating Conditions may affect device reliability.

### Recommendation Operating Condition at $T_a = 25^\circ\text{C}$

Parameter	Symbol	Conditions	Ratings	Unit
Supply voltage range1	$V_{CC\text{ op}}$	$V_{CC}$	2.7 to 5.5	V
PWM frequency	$F_{pwm}$	PWM MODE	300 to 100k	Hz

### Electrical Characteristics Analog block at $T_a = 25^\circ\text{C}$ , $V_{CC} = 3.6\text{V}$ , unless otherwise specified

Parameter	Symbol	Conditions	Ratings			Unit
			min	typ	max	
Standby current dissipation	$I_{CC1}$	SHUTDOWN		0	5	$\mu\text{A}$
DC/DC current dissipation	$I_{CC2}$	$V_{OUT} = 30\text{V}$ , $I_{LED} = 20\text{mA}$			1	mA
FB voltage	$V_{fb}$	PWM duty 100%	0.19	0.2	0.21	V
FB pin leak current	$I_{fb}$				1	$\mu\text{A}$
OVP voltage	$V_{ovp}$	SW	37	38	39	V
SWOUT ON resistance	$R_{on}$	$I_L = 100\text{mA}$		700		$\text{m}\Omega$
NMOS switch current limit	$I_{LIM}$	$V_{fb} = 200\text{mV}$		0.7		A
OSC frequency	$F_{osc}$			600		kHz
High level input voltage	$V_{INH}$	SWIRE	1.5		$V_{CC}$	V
Low level input voltage	$V_{INL}$	SWIRE	0		0.4	V
Under voltage lockout	$V_{uvlo}$	$V_{IN}$ falling		2.2		V
SWIRE output voltage for Acknowledge	$V_{ack}$	$R_{pullup} = 15\text{k}\Omega$			0.4	V

### Recommended SWIRE Timing at $T_a = 25^\circ\text{C}$ , $V_{CC} = 3.6\text{V}$ , unless otherwise specified

Parameter	Symbol	Conditions	Ratings			Unit
			min	typ	max	
SWIRE setup time from shutdown	$T_{on}$		20			$\mu\text{s}$
SWIRE mode selectable time	$T_{sel}$		1		2.2	ms
SWIRE delay time to start digital mode detection	$T_{w0}$		100			$\mu\text{s}$
SWIRE low time to switch to digital mode	$T_{w1}$		260			$\mu\text{s}$
SWIRE low time to shutdown	$T_{off}$		8.9			ms
SWIRE start time for digital mode programming	$T_{start}$		2			$\mu\text{s}$
SWIRE end time for digital mode programming	$T_{end}$		2		360	$\mu\text{s}$

Continued on next page.

# LV52204MT

Continued from preceding page.

SWIRE High time of bit 0	Th0	Bit detection = 0	2	180	μs
SWIRE Low time of bit 0	Tl0	Bit detection = 0	Th0 × 2	360	μs
SWIRE High time of bit 1	Th1	Bit detection = 1	Tl1 × 2	360	μs
SWIRE Low time of bit1	Tl1	Bit detection = 1	2	180	μs
DCDC startup delay	Tdel			2	ms
Delay time of Acknowledge	Tackd			2	μs
Duration of Acknowledge	Tack			512	μs

## Block Diagram

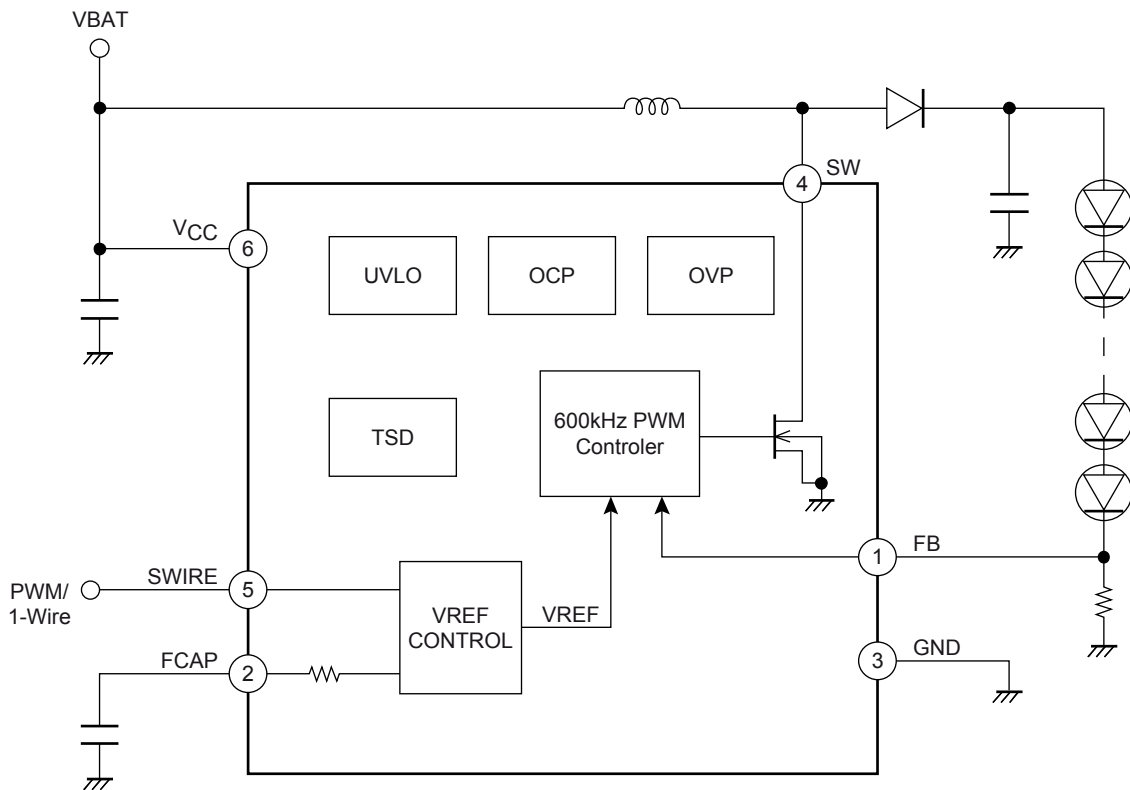

## Pin Function

PIN #	Pin Name	Description
1	FB	Feedback pin.
2	FCAP	Filtering capacitor terminal for PWM mode.
3	GND	Ground
4	SW	Switch pin. Drain of the internal power FET.
5	SWIRE	1-wire dimming control and PWM dimming input (active High).
6	V <sub>CC</sub>	Supply voltage.
	Expose-pad	Connect to GND on PCB.

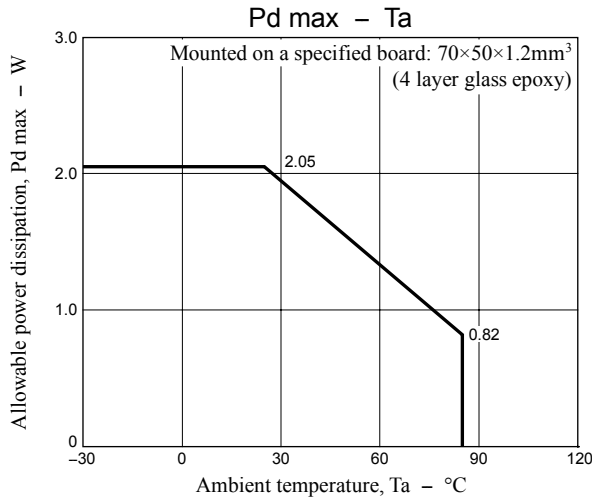

### LED Current Setting

LED current is set by an external resistor connected between the FB pin and ground.

$$I_{LED} = V_{FB}/R_{FB}$$

The  $V_{FB}$  can be controlled by two dimming modes, PWM Mode or Digital Mode. In PWM mode, PWM input is converted into a near DC current by the internal resistor R that was equivalent to 60kΩ (±10%) and the external capacitor  $C_{FCAP}$  as a low pass filter with a cut-off frequency  $f_c = 1/2\pi R_{FCAP}$ . The  $V_{FB}$  can be adjusted by altering the duty cycle of the PWM signal (See Fig.1).

$$V_{FB} = 200 \text{ (mV)} \times \text{PWM Duty (\%)}$$

On the other hand,  $V_{FB}$  can be selected one from among 32 steps in Digital Mode (See Fig.2).

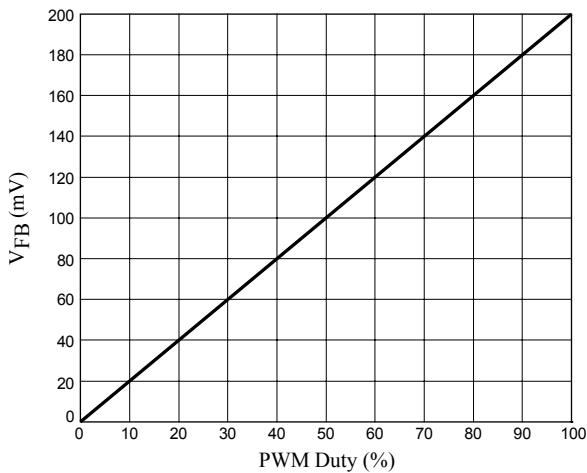

Fig1.  $V_{FB}$  vs. PWM Duty (PWM mode)

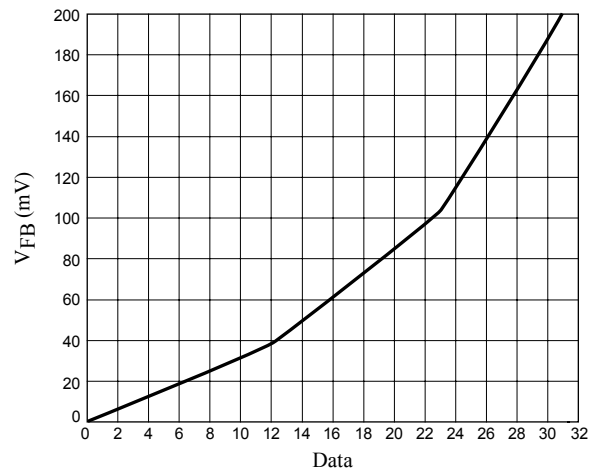

Fig2.  $V_{FB}$  vs. Data Register Value (Digital mode)

### Dimming Mode Selection

Dimming Mode is selected by a specific pattern of the SWIRE within  $T_{sel}$  (1ms) from the startup of the device every time. In order to startup the device, the SWIRE must keep high for longer than  $T_{on}$ .

**PWM Mode**

The dimming mode is set to PWM mode when it is not recognized as a digital mode within Tsel. To enter Digital Mode, the SWIRE is required keeping in low state for Tw1 (See Fig.4). If the PWM frequency is used faster than 6.6kHz, the dimming mode is set to PWM mode only. But slower than 6.6kHz, it is necessary to avoid entering the digital mode condition, such as SWIRE keeps high for longer than Tsel. PWM is enabled after Tdel from Tsel.

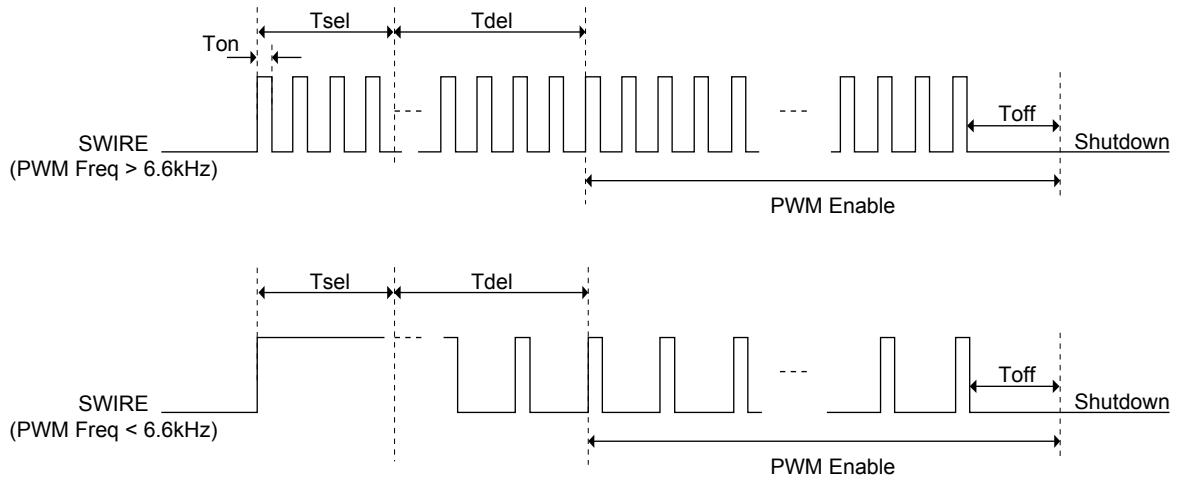

Fig3. SWIRE Timing Diagram in PWM mode

**Digital Mode**

To enter Digital Mode, SWIRE should be taken high for more than Tw0 (100µs) from the first rising edge and keep low state for Tw1(260µs) before Tsel(1ms).

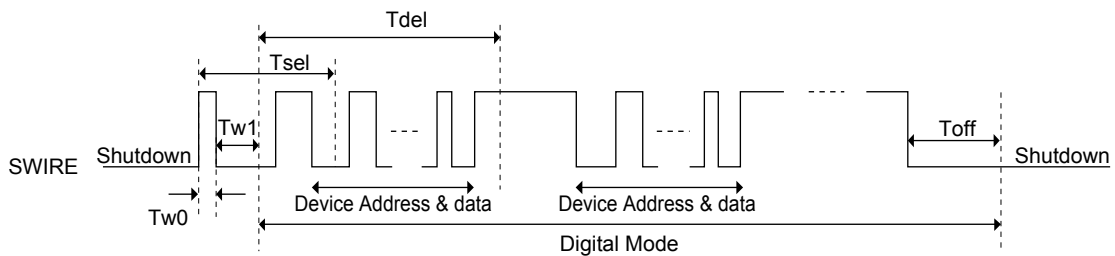

Fig4. SWIRE Timing Diagram in Digital mode

It is required sending the device address byte and the data byte to select VFB. The bit detection is determined by the ratio of Th and Tl (See Fig6). The start condition for the bit transmission required SWIRE high for at least Tstart. The end condition is required SWIRE low for at least Tend. When data is not being transferred, SWIRE is set in the “H” state. These registers are initialized with POR (Power On Reset).

In the LV52204MT, the device address (DA7 to DA0) is specified as “01110010”. D7 is setting for the acknowledge response. If the device address and the data byte are transferred on D7 = 1, the ACK signal is sent from the receive side to the send side. The acknowledge signal is issued when SWIRE on the send side is released and SWIRE on the receive side is set to low state. D6 and D5 need to send 0. D4 to D0 allow to changing the FB voltage.

	Register	BIT	Description
Device Address	DA7	7	0
	DA6	6	1
	DA5	5	1
	DA4	4	1
	DA3	3	0
	DA2	2	0
	DA1	1	1
	DA0	0	0

Table1. Device Address Description

# LV52204MT

	Register	BIT	Description
Data	D7	7	0 = Acknowledge disabled 1 = Acknowledge enabled
	D6	6	0
	D5	5	0
	D4	4	Data bit 4
	D3	3	Data bit 3
	D2	2	Data bit 2
	D1	1	Data bit 1
	D0	0	Data bit 0

*Table2. Data Description*

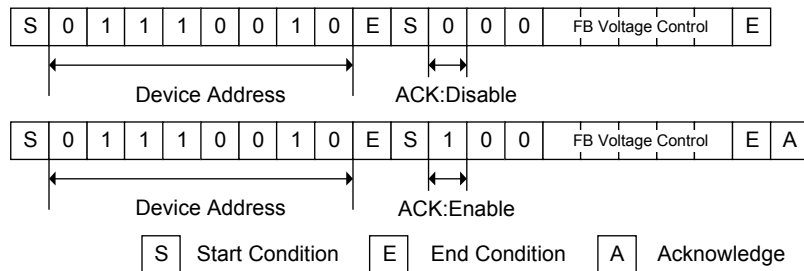

*Fig5. Example of writing data*

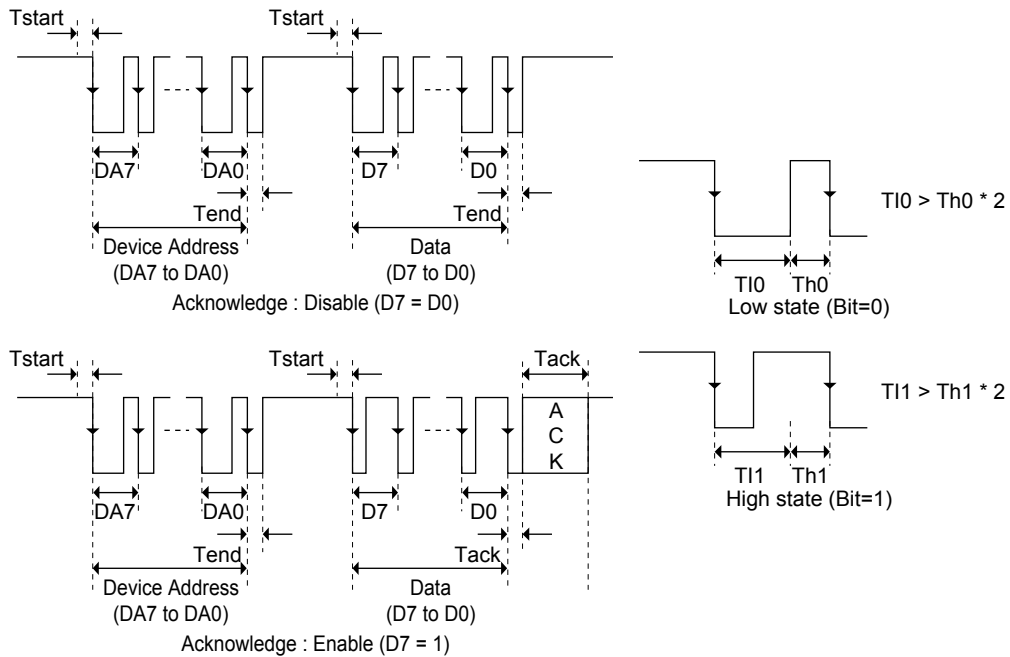

*Fig6.Bit detection Diagram*

# LV52204MT

	D7	D6	D5	D4	D3	D2	D1	D0	FB voltage (mV)
0	1/0	0	0	0	0	0	0	0	0
1	1/0	0	0	0	0	0	0	1	5
2	1/0	0	0	0	0	0	1	0	8
3	1/0	0	0	0	0	0	1	1	11
4	1/0	0	0	0	0	1	0	0	14
5	1/0	0	0	0	0	1	0	1	17
6	1/0	0	0	0	0	1	1	0	20
7	1/0	0	0	0	0	1	1	1	23
8	1/0	0	0	0	1	0	0	0	26
9	1/0	0	0	0	1	0	0	1	29
10	1/0	0	0	0	1	0	1	0	32
11	1/0	0	0	0	1	0	1	1	35
12	1/0	0	0	0	1	1	0	0	38
13	1/0	0	0	0	1	1	0	1	44
14	1/0	0	0	0	1	1	1	0	50
15	1/0	0	0	0	1	1	1	1	56
16	1/0	0	0	1	0	0	0	0	62
17	1/0	0	0	1	0	0	0	1	68
18	1/0	0	0	1	0	0	1	0	74
19	1/0	0	0	1	0	0	1	1	80
20	1/0	0	0	1	0	1	0	0	86
21	1/0	0	0	1	0	1	0	1	92
22	1/0	0	0	1	0	1	1	0	98
23	1/0	0	0	1	0	1	1	1	104
24	1/0	0	0	1	1	0	0	0	116
25	1/0	0	0	1	1	0	0	1	128
26	1/0	0	0	1	1	0	1	0	140
27	1/0	0	0	1	1	0	1	1	152
28	1/0	0	0	1	1	1	0	0	164
29	1/0	0	0	1	1	1	0	1	176
30	1/0	0	0	1	1	1	1	0	188
31	1/0	0	0	1	1	1	1	1	*200

(\*Default)

*Table3. Data Register vs. FB Voltage*

**Start up and Shutdown**

The device becomes enabled when SWIRE is initially taken high. The dimming mode is determined within  $T_{sel}$  and the boost converter start up after  $T_{del}$ . To place the device into shutdown mode, the SWIRE must be held low for  $T_{off}$ .

PWM MODE

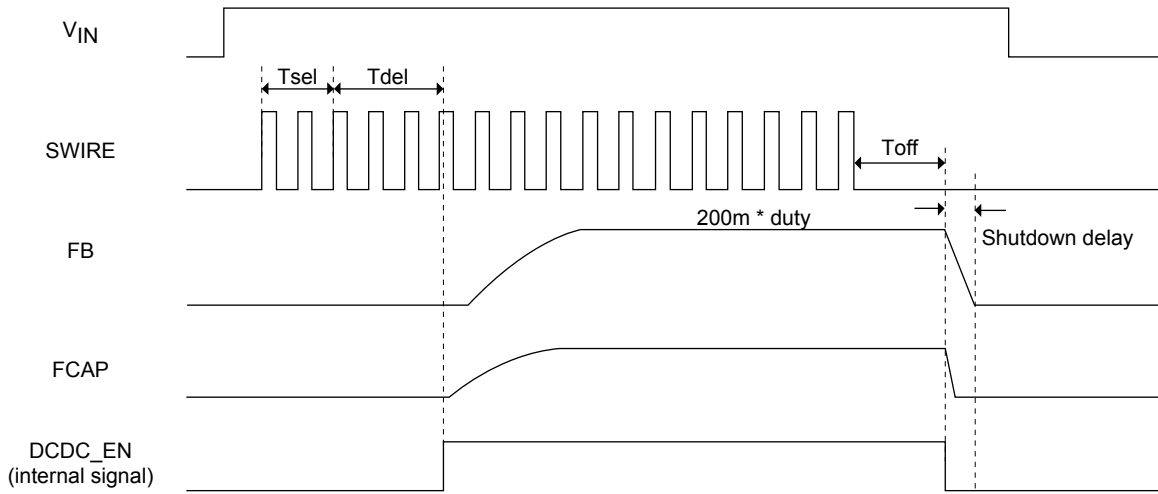

Digital MODE

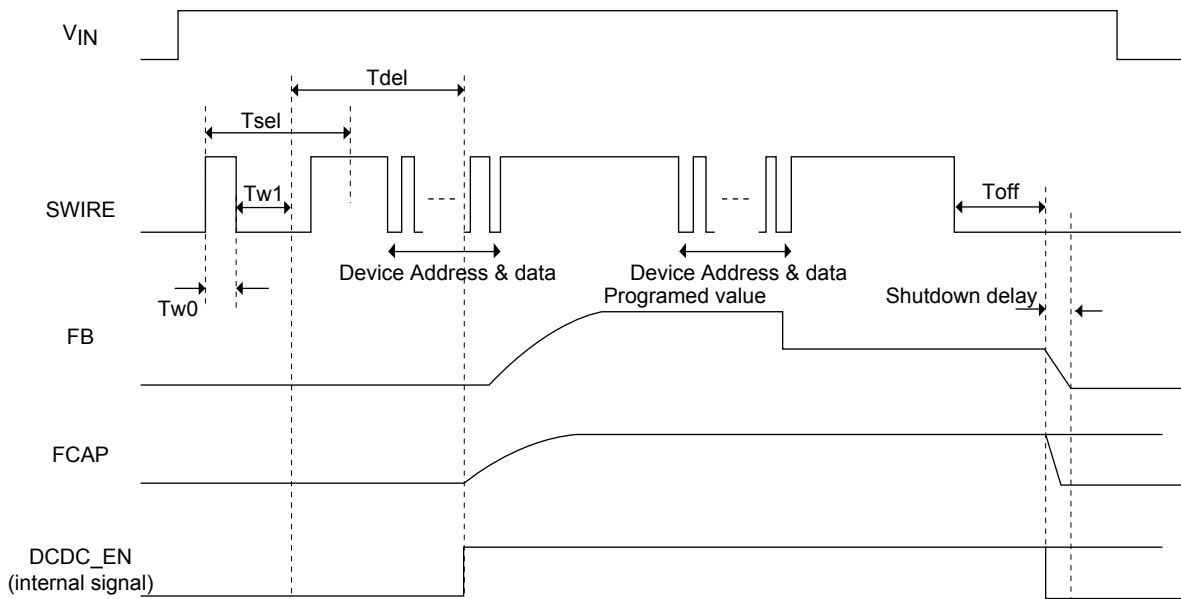
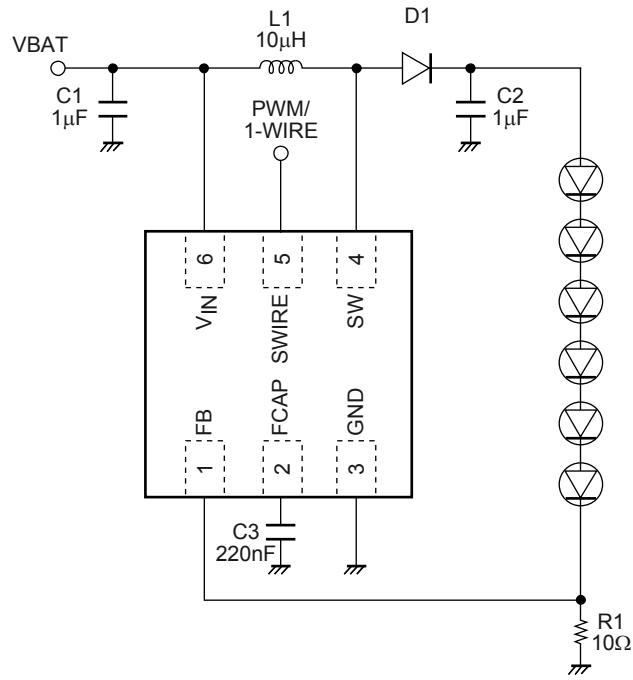

Fig7. Start up and shutdown diagram



# LV52204MT

## 6LEDs



- L1: VLS3012T-100M72 (TDK), VLF302512M-100M (TDK)  
D1: MBR0540T1 (ON semi), NSR05F40 (ONsemi)  
C2: GRM21BR71H105K (Murata), C1608X5R1H105K (TDK)

# LV52204MT

Typical Characteristics ( $V_{IN} = 3.6V$ ,  $L = 22\mu H$ ,  $T = 25^\circ C$ , unless otherwise specified)

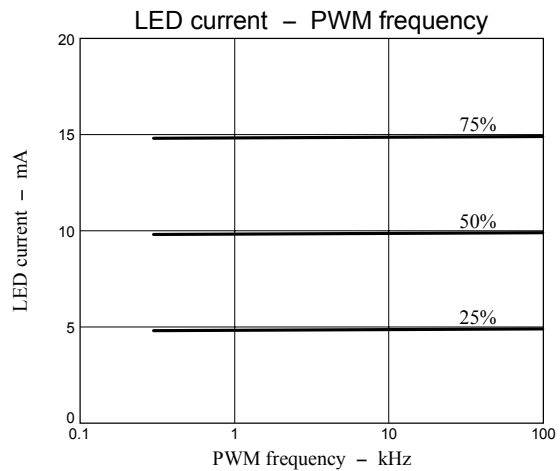
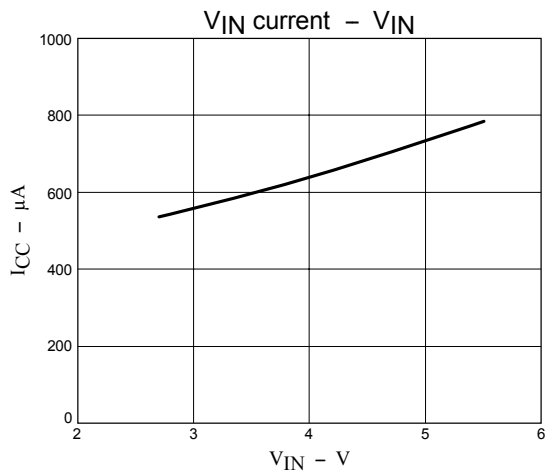
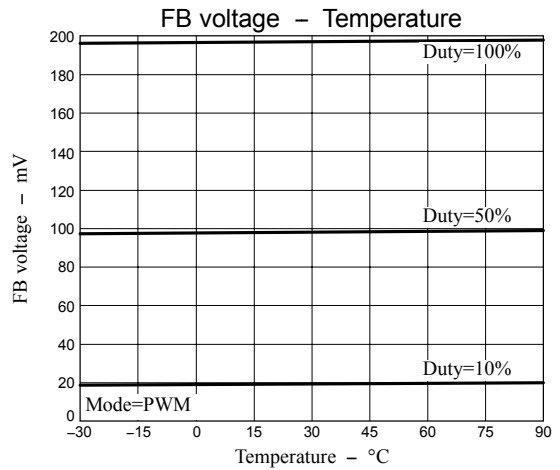
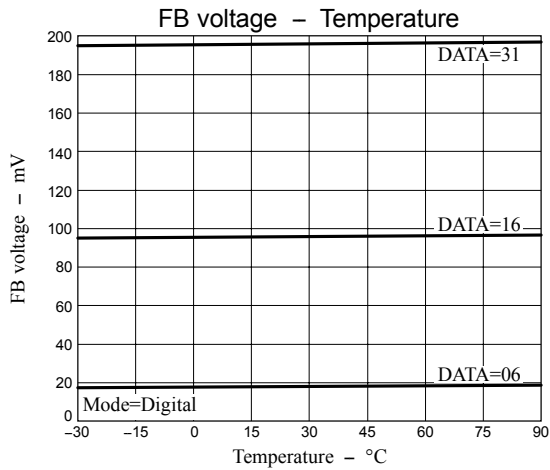
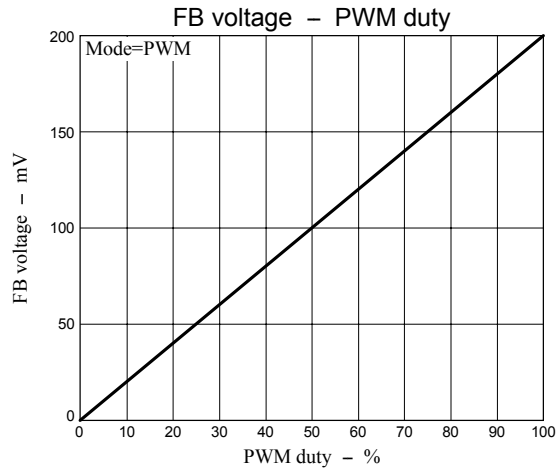
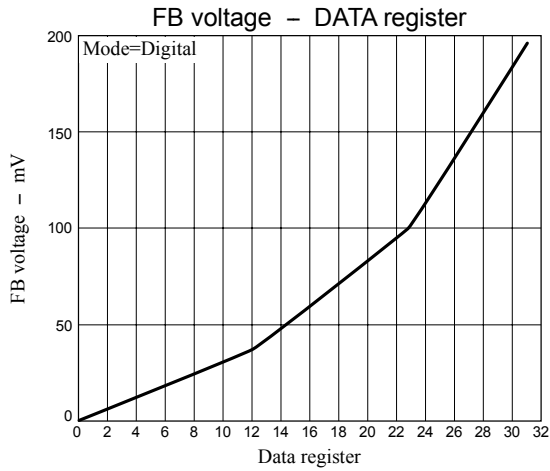
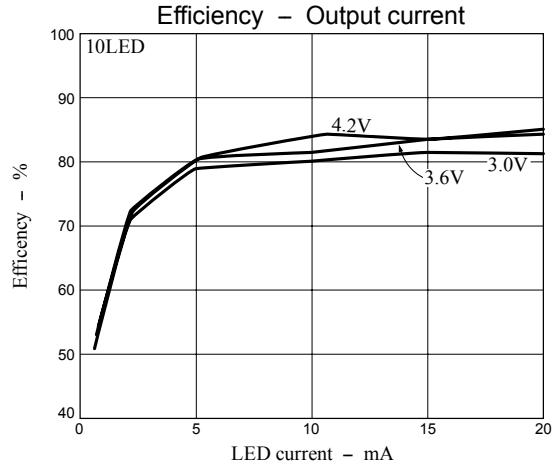
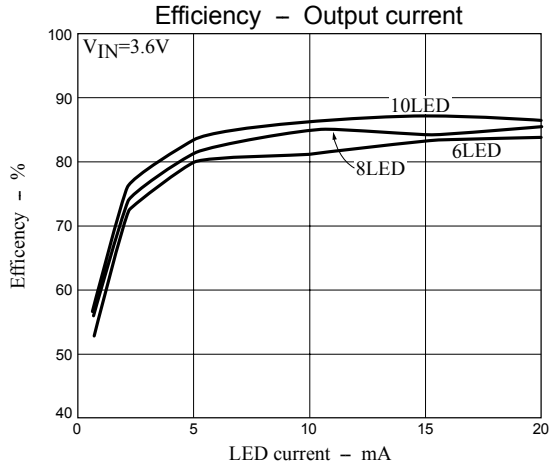

**PACKAGE DIMENSIONS**

**WDFN6 2x2, 0.65P**

CASE 511BR-01

ISSUE O

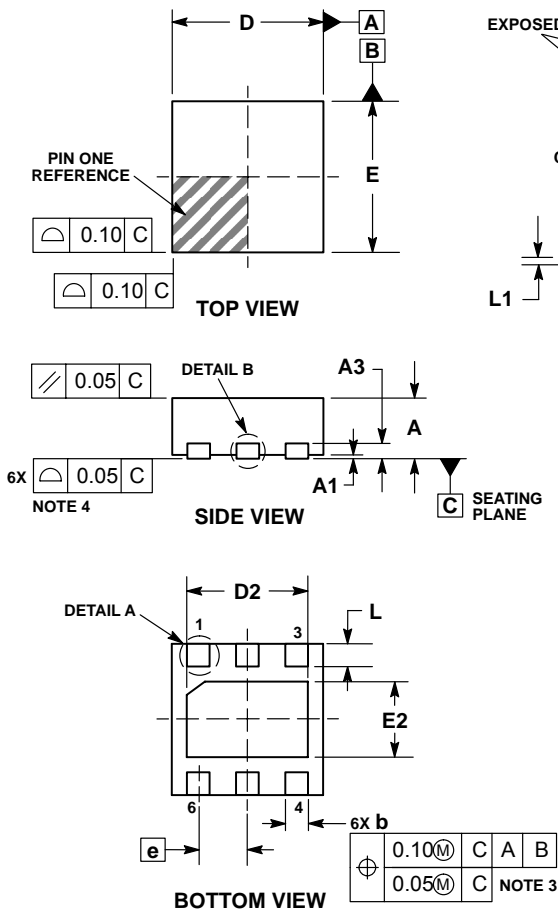

**NOTES:**

1. DIMENSIONING AND TOLERANCING PER ASME Y14.5M, 1994.
2. CONTROLLING DIMENSION: MILLIMETERS.
3. DIMENSION b APPLIES TO PLATED TERMINAL AND IS MEASURED BETWEEN 0.15 AND 0.25 mm FROM THE TERMINAL TIP.
4. COPLANARITY APPLIES TO THE EXPOSED PAD AS WELL AS THE TERMINALS.

MILLIMETERS		
DIM	MIN	MAX
A	0.70	0.80
A1	0.00	0.05
A3	0.20 REF	
b	0.25	0.35
D	2.00 BSC	
D2	1.50	1.70
E	2.00 BSC	
E2	0.90	1.10
e	0.65 BSC	
L	0.20	0.40
L1	---	0.15

**GENERIC MARKING DIAGRAM\***



XX = Specific Device Code  
M = Date Code

\*This information is generic. Please refer to device data sheet for actual part marking. Pb-Free indicator, G or microdot ■, may or may not be present.

**RECOMMENDED MOUNTING FOOTPRINT**

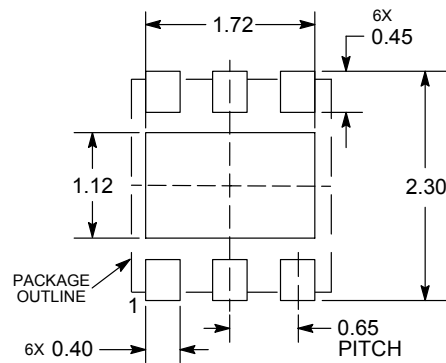

DIMENSIONS: MILLIMETERS

# LV52204MT

---

## ORDERING INFORMATION

Device	Package	Shipping (Qty / Packing)
LV52204MTTBG	WDFN6 (2x2) (Pb-Free)	3000 / Tape & Reel

ON Semiconductor and the ON logo are registered trademarks of Semiconductor Components Industries, LLC (SCILLC). SCILLC owns the rights to a number of patents, trademarks, copyrights, trade secrets, and other intellectual property. A listing of SCILLC's product/patent coverage may be accessed at [www.onsemi.com/site/pdf/Patent-Marking.pdf](http://www.onsemi.com/site/pdf/Patent-Marking.pdf). SCILLC reserves the right to make changes without further notice to any products herein. SCILLC makes no warranty, representation or guarantee regarding the suitability of its products for any particular purpose, nor does SCILLC assume any liability arising out of the application or use of any product or circuit, and specifically disclaims any and all liability, including without limitation special, consequential or incidental damages. "Typical" parameters which may be provided in SCILLC data sheets and/or specifications can and do vary in different applications and actual performance may vary over time. All operating parameters, including "Typicals" must be validated for each customer application by customer's technical experts. SCILLC does not convey any license under its patent rights nor the rights of others. SCILLC products are not designed, intended, or authorized for use as components in systems intended for surgical implant into the body, or other applications intended to support or sustain life, or for any other application in which the failure of the SCILLC product could create a situation where personal injury or death may occur. Should Buyer purchase or use SCILLC products for any such unintended or unauthorized application, Buyer shall indemnify and hold SCILLC and its officers, employees, subsidiaries, affiliates, and distributors harmless against all claims, costs, damages, and expenses, and reasonable attorney fees arising out of, directly or indirectly, any claim of personal injury or death associated with such unintended or unauthorized use, even if such claim alleges that SCILLC was negligent regarding the design or manufacture of the part. SCILLC is an Equal Opportunity/Affirmative Action Employer. This literature is subject to all applicable copyright laws and is not for resale in any manner.