



SANYO Semiconductors

# DATA SHEET

## LV5608LP — Bi-CMOS LSI For CCD Charge pump power supply

### Overview

The LV5608LP is charge pump power supply for CCD.

### Functions

- The charge pump boosts the +3.3V input by multiplying with +6, then by -3 to regulate the voltage to the specified level.
- The output voltage is +15V, -7.5V necessary for CCD.
- Soft start function incorporated, which reduces the inrush current at start of charge pump.
- Short-circuit protection function incorporated.
- Four types of operating frequency selectable.

### Specifications

#### Absolute Maximum Ratings at $T_a = 25^\circ\text{C}$

Parameter	Symbol	Conditions	Ratings	Unit
Maximum supply voltage	$V_{DD\ max}$		3.5	V
Allowable power dissipation	$P_d\ max$	with specified substrate *1	0.8	W
Operating temperature	$T_{opr}$		-20 to +80	$^\circ\text{C}$
Storage temperature	$T_{stg}$		-40 to +125	$^\circ\text{C}$

\*1 : Specified substrate : 40×50×0.8mm<sup>3</sup>, glass epoxy four-layer (2S2P) board

#### Allowable Operating Ratings at $T_a = 25^\circ\text{C}$ , PGND = 0V

Parameter	Symbol	Conditions	Ratings			Unit
			min	typ	max	
Supply voltage	$V_{DD}$		3.0	3.3	3.45	V
Input CLK frequency	CKIN	SEL=H *2	0.1		8	MHz
Input High voltage	$V_{INH}$	EN pin	$0.7V_{DD}$		$V_{DD}$	V
Input Low voltage	$V_{INL}$	EN pin	-0.1		0.4	V

\*2 : Note that the charge pump frequency should be adjusted with S0/S1 so that it becomes 2 MHz or less.

- Any and all SANYO Semiconductor products described or contained herein do not have specifications that can handle applications that require extremely high levels of reliability, such as life-support systems, aircraft's control systems, or other applications whose failure can be reasonably expected to result in serious physical and/or material damage. Consult with your SANYO Semiconductor representative nearest you before using any SANYO Semiconductor products described or contained herein in such applications.
- SANYO Semiconductor assumes no responsibility for equipment failures that result from using products at values that exceed, even momentarily, rated values (such as maximum ratings, operating condition ranges, or other parameters) listed in products specifications of any and all SANYO Semiconductor products described or contained herein.

**SANYO Semiconductor Co., Ltd.**

TOKYO OFFICE Tokyo Bldg., 1-10, 1 Chome, Ueno, Taito-ku, TOKYO, 110-8534 JAPAN



# LV5608LP

## Pin Assignment

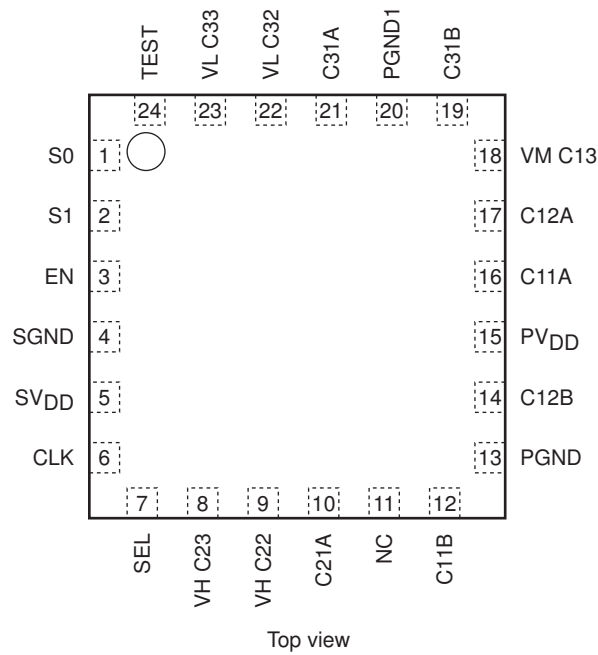

## Pin Function

Pin No.	Name	Mode
1	S0	Charge pump frequency changeover pin
2	S1	Charge pump frequency changeover pin
3	EN	System enable pin (Hi active)
4	SGND	Small signal system GND pin
5	SVDD	Small signal system VDD pin
6	CLK	External CLK input pin
7	SEL	CLK selector pin (L: built-in CLK, H: external CLK)
8	VH C23	VH (+15V) regulator output pin
9	VH C22	Boost voltage output (+6VDD)
10	C21A	Boost capacitor connection pin (on the load transfer side)
11	NC	
12	C11B	Boost capacitor connection pin (driver side)
13	PGND	+3-fold boost power GND pin
14	C12B	Boost capacitor connection pin (driver side)
15	PVDD	Power system VDD pin
16	C11A	Boost capacitor connection pin (load transfer side)
17	C12A	Boost capacitor connection pin (load transfer side)
18	VM C13	Boost voltage output (+3VDD)
19	C31B	+2-fold and -1-fold boost capacitor connection pin (driver side)
20	PGND1	+2-fold and -1-fold boost power GND pin
21	C31A	-1-fold boost capacitor connection pin (load transfer side)
22	VL C32	Boost voltage output (-3VDD)
23	VL C33	VL (-7.5V) regulator output pin
24	TEST	Test pin (OPEN or GND short-circuited)

# LV5608LP

## Block Diagram

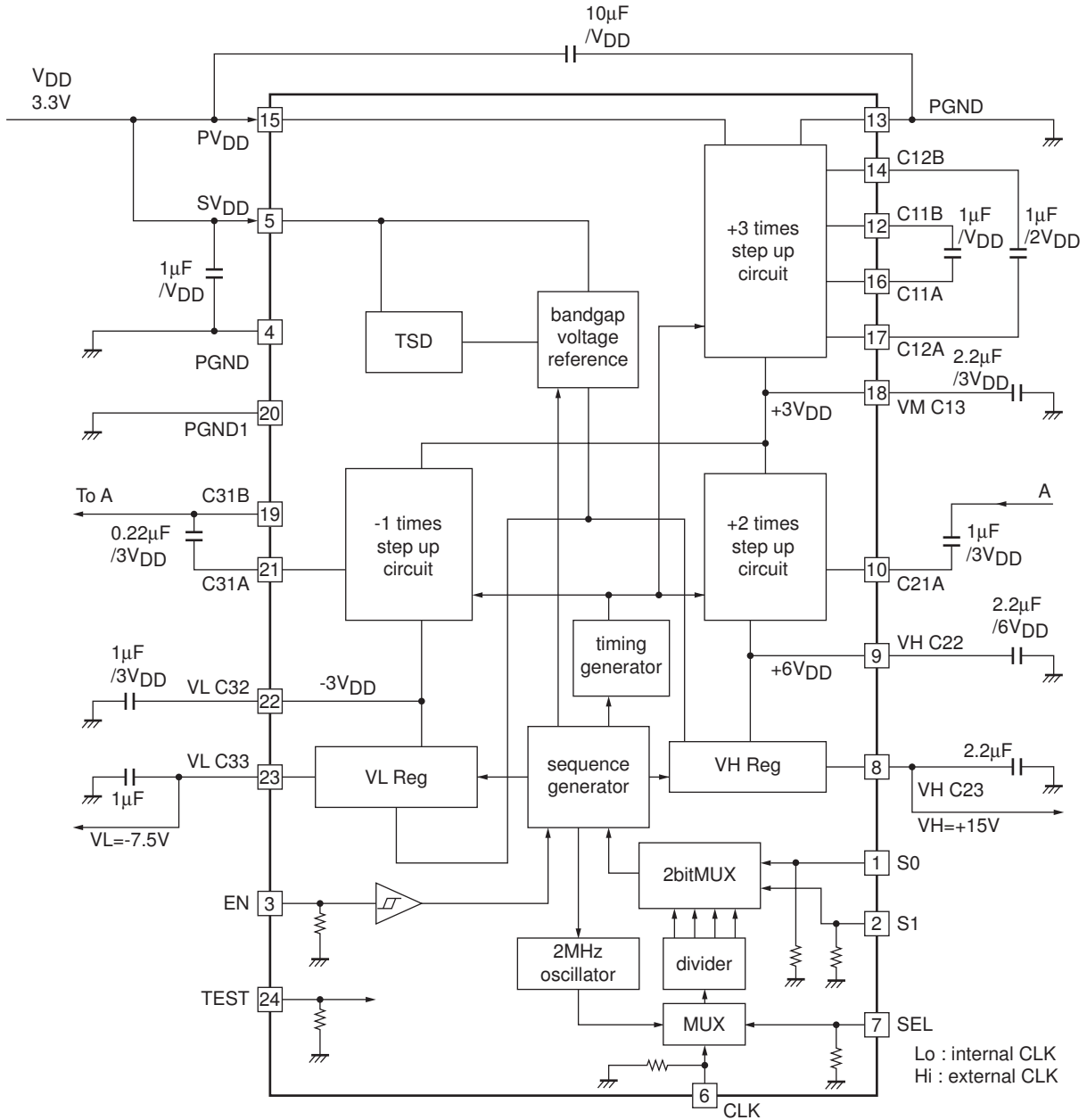

# LV5608LP

## Short-circuit Protection

VH and VL output pins incorporate the short-circuit protection function.

When the output pins are short-circuited to allow the large current to flow, IC is latched OFF to interrupt output.

To reset from the interrupted state, set the EN pin to L, then reset it again to H.

## Frequency Selection

The charge pump operating frequency can be changed with S0 and S1 logics.

For light load, the reactive load can be reduced by lowering the operating frequency.

SEL logic also enables synchronous operation with external CLK.

The charge pump is operated with the frequency equivalent to 1/2 of input CLK.

(The IC internal oscillator is used for the sequence, so that it is normally ON regardless of SEL.

For minimum 9.4ms after startup with the EN signal set to H, the IC internal clock is used to operate the charge pump with 1 MHz regardless of the input of SEL, S0, and S1 pins. After the 9.4ms(min) period, the charge pump frequency is changed over according to the state of SEL, S0, and S1 pins. The changeover frequency is set as shown in the table right.

S0	S1	CP operating frequency	
		SEL=L	SEL=H
L	L	1MHz	1/2 CLK
H	L	500kHz	1/4 CLK
L	H	250kHz	1/8 CLK
H	H	125kHz	1/16 CLK

SEL	
L	IC internal oscillator
H	Synchronous operation with external CLK

## Internal Equivalent Circuit

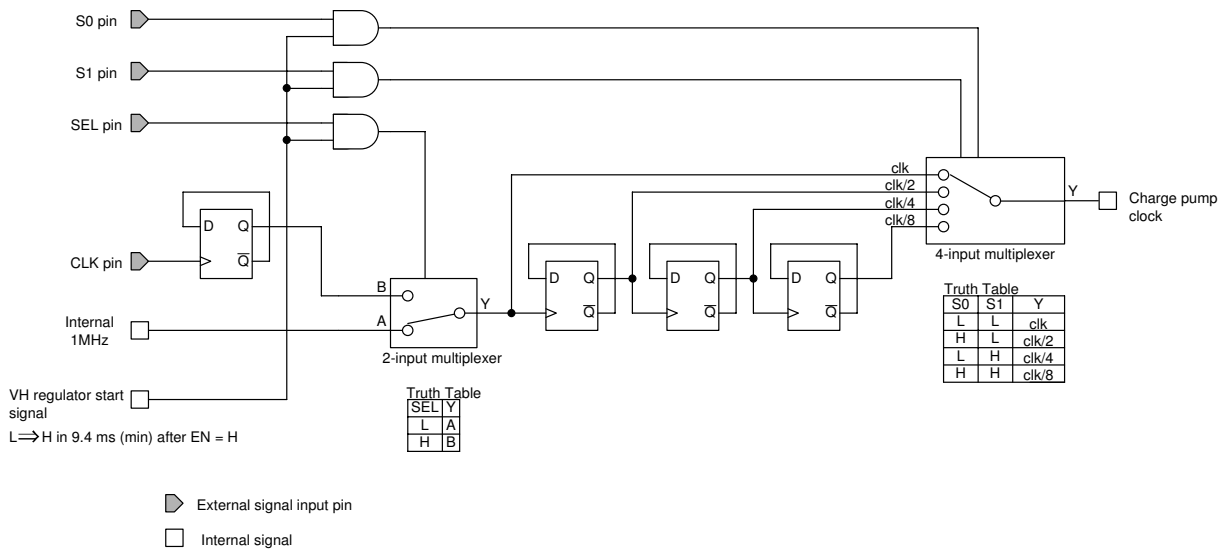

## External clock signal startup sequence

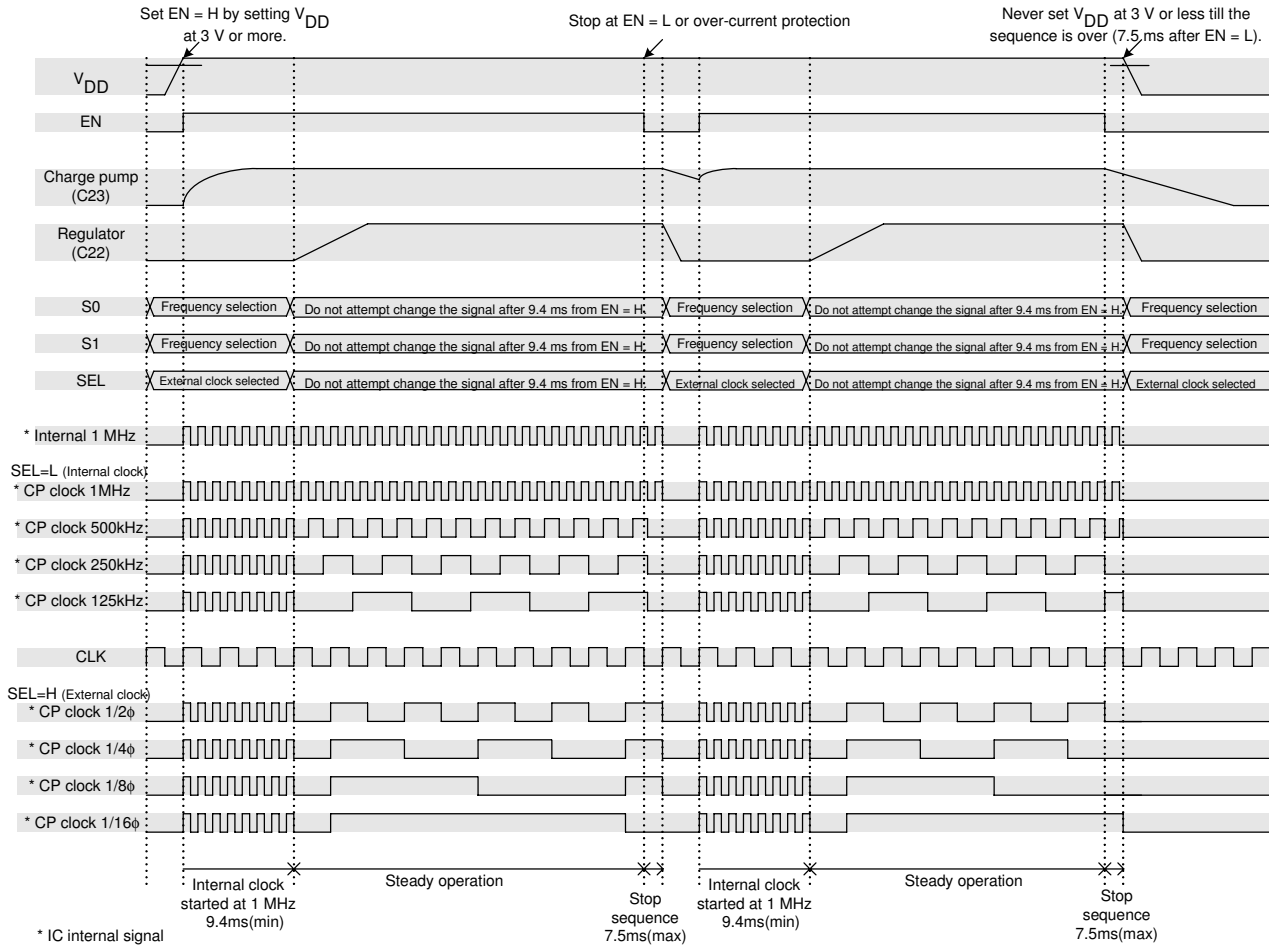

## EN Pin and $V_{DD}$

Though the sequence operation is made at startup, startup is not effectuated if the internal circuit has not been reset.

To reset the internal circuit, it is necessary to keep the EN pin at L till  $V_{DD}$  becomes 3V or more.

Note that operation with  $V_{DD}$  and EN pin short-circuited cannot be made.

Since the sequence operation is incorporated for stop of operation, the charge pump remains active till 7.5ms (max) passes after setting the EN pin to L. During this period,  $V_{DD}$  must be kept at 3V or more to allow the internal sequence logic to operate correctly.

# LV5608LP

## Rise/fall Sequence

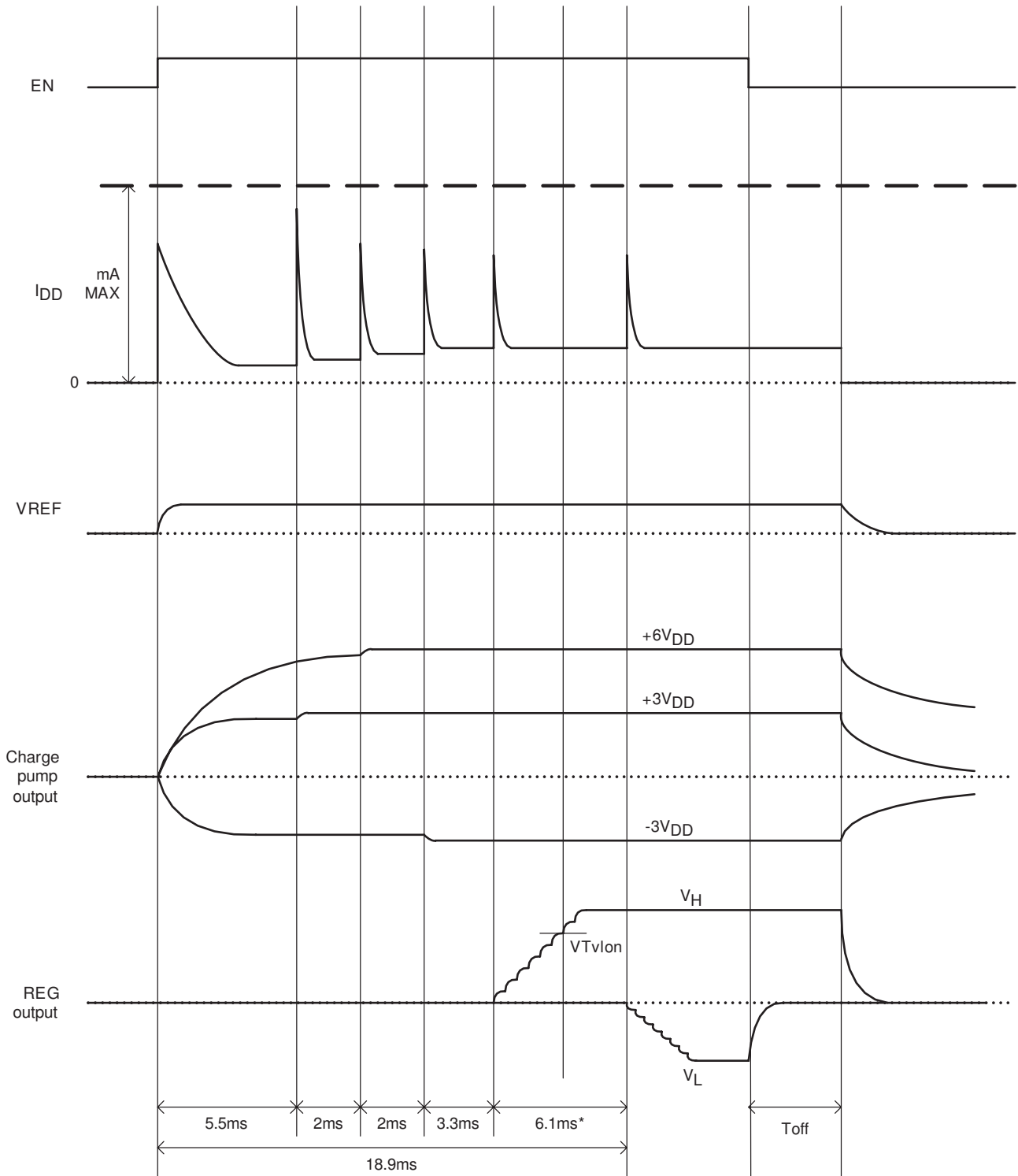

\*The V<sub>L</sub> startup time at V<sub>H</sub> ≥ 10V and after elapse of 6.1ms is the reference time for CLK = 2MHz.

- Specifications of any and all SANYO Semiconductor products described or contained herein stipulate the performance, characteristics, and functions of the described products in the independent state, and are not guarantees of the performance, characteristics, and functions of the described products as mounted in the customer's products or equipment. To verify symptoms and states that cannot be evaluated in an independent device, the customer should always evaluate and test devices mounted in the customer's products or equipment.
- SANYO Semiconductor Co., Ltd. strives to supply high-quality high-reliability products. However, any and all semiconductor products fail with some probability. It is possible that these probabilistic failures could give rise to accidents or events that could endanger human lives, that could give rise to smoke or fire, or that could cause damage to other property. When designing equipment, adopt safety measures so that these kinds of accidents or events cannot occur. Such measures include but are not limited to protective circuits and error prevention circuits for safe design, redundant design, and structural design.
- In the event that any or all SANYO Semiconductor products (including technical data, services) described or contained herein are controlled under any of applicable local export control laws and regulations, such products must not be exported without obtaining the export license from the authorities concerned in accordance with the above law.
- No part of this publication may be reproduced or transmitted in any form or by any means, electronic or mechanical, including photocopying and recording, or any information storage or retrieval system, or otherwise, without the prior written permission of SANYO Semiconductor Co., Ltd.
- Any and all information described or contained herein are subject to change without notice due to product/technology improvement, etc. When designing equipment, refer to the "Delivery Specification" for the SANYO Semiconductor product that you intend to use.
- Information (including circuit diagrams and circuit parameters) herein is for example only; it is not guaranteed for volume production. SANYO Semiconductor believes information herein is accurate and reliable, but no guarantees are made or implied regarding its use or any infringements of intellectual property rights or other rights of third parties.

This catalog provides information as of March, 2007. Specifications and information herein are subject to change without notice.