



ON Semiconductor®

<http://onsemi.com>

# LV5771QA

Bi-CMOS IC

## Step-down Voltage Switching Regulator

### Overview

LV5771QA is a step-down voltage switching regulator.

### Features and Functions

- Wide Input dynamic range: 8V to 42V
- Current mode type
- Built-in pulse-by-pulse OCP circuit: detects over current by using ON resistance of an external of an external MOS external resistance for over current detection.
- Over current protection: HICCUP MODE
- Built-in output voltage correction circuit
- Droops when frequency FOLD BACK is negative
- Thermal shutdown
- Fixed frequency: 1MHz
- Load-independent soft start circuit
- Over voltage protection

### Specifications

**Absolute Maximum Ratings** at  $T_a = 25^\circ\text{C}$

Parameter	Symbol	Conditions	Ratings	Unit
Supply voltage	$V_{IN\ max}$		45	V
Allowable pin voltage	$V_{IN, SW}$		45	V
	HDRV, CBOOT		52	V
	LDRV		6	V
	Between CBOOT and SW, Between CBOOT and HDRV		6	V
	EN, $I_{LIM}$		$V_{IN}+0.3$	V
	Between $V_{IN}$ and $I_{LIM}$		1	V
	$V_{DD}$		6	V
	SS, COMP, FB, SDIN		$V_{DD}+0.3$	V
SNS_OCP, SNS_COM, SNS_CS		7	V	
Allowable Power dissipation	$P_d\ max$	Mounted on a specified board. *	0.65	W
Operating temperature	$T_{opr}$		-40 to +85	°C
Storage temperature	$T_{stg}$		-55 to +150	°C
Junction temperature	$T_j\ max$		150	°C

\* Specified board: 24.0mm × 15.0mm × 1.6mm, glass epoxy 2-layer board.

Caution 1) Absolute maximum ratings represent the values which cannot be exceeded for any length of time.

Caution 2) Even when the device is used within the range of absolute maximum ratings, as a result of continuous usage under high temperature, high current, high voltage, or drastic temperature change, the reliability of the IC may be degraded. Please contact us for the further details.

Stresses exceeding Maximum Ratings may damage the device. Maximum Ratings are stress ratings only. Functional operation above the Recommended Operating Conditions is not implied. Extended exposure to stresses above the Recommended Operating Conditions may affect device reliability.

### ORDERING INFORMATION

See detailed ordering and shipping information on page 12 of this data sheet.

# LV5771QA

## Recommendation Operating Conditions at Ta = 25°C

Parameter	Symbol	Conditions	Ratings	Unit
Supply voltage range	V <sub>IN</sub>		8 to 42	V
Error amplifier input voltage	V <sub>FB</sub>		0 to 1.6	V

## Electrical Characteristics at Ta = 25°C, V<sub>IN</sub> = 12V

Parameter	Symbol	Conditions	Ratings			Unit
			min	typ	max	
<b>Reference voltage block</b>						
5V power supply	V <sub>DD</sub>	I <sub>OUT</sub> = 0 to 5mA	4.7	5.2	5.7	V
Internal reference voltage	V <sub>REF</sub>	Including offset of E/A	0.69	0.7	0.71	V
<b>Triangular waveform oscillator block</b>						
Oscillation frequency1	F <sub>OSC1</sub>	V <sub>IN</sub> = 12V (≈8V to 18V)	870	1000	1130	kHz
Oscillation frequency2	F <sub>OSC2</sub>	V <sub>IN</sub> = 24V (≈18V to 30V)		1/2 × F <sub>OSC1</sub>		kHz
Oscillation frequency3	F <sub>OSC3</sub>	V <sub>IN</sub> = 36V (≈30V to 42V)		1/3 × F <sub>OSC1</sub>		kHz
Oscillation Fold back sense voltage	V <sub>OSC_FB</sub>	After power is supplied to SS, voltage is detected FB		0.5		V
Oscillation frequency after fold back	F <sub>OSC_FB</sub>		100	150	200	kHz
Maximum ON duty	D <sub>MAX</sub>		75			%
<b>ON/OFF circuit block</b>						
EN ON voltage	V <sub>EN_ON</sub>	V <sub>IN</sub> = 8 to 42V		3.4	4.3	V
EN OFF voltage	V <sub>EN_OFF</sub>	V <sub>IN</sub> = 8 to 42V	1.0	1.2		V
<b>Soft Start circuit block</b>						
Soft start source current	I <sub>SS_SC</sub>	EN > 5V, SS = 0V	4	5	6	μA
Soft start sink current	I <sub>SS_SK</sub>	EN < 1V, V <sub>DD</sub> = 5V, SS = 1V		2		mA
Voltage to end the soft start function	V <sub>SS_END</sub>		0.7	0.9	1.1	V
<b>UVLO circuit block</b>						
UVLO lock release voltage	V <sub>UVLO</sub>		7.0	7.4	7.8	V
UVLO hysteresis	V <sub>UVLO_H</sub>			0.6		V
<b>Error amplifier</b>						
Input bias current	I <sub>EA_IN</sub>				100	nA
Error amplifier trans conductance	G <sub>EA</sub>		1000	1400	1800	μA/V
Sink output current	I <sub>EA_OSK</sub>	FB = 1.0V		-100		μA
Source output current	I <sub>EA_OSC</sub>	FB = 0V		100		μA
<b>Over current limiter circuit block1</b>						
Over current detection comparator 1 Offset voltage	V <sub>SNS_OCP</sub>	(R6 = 20mΩ)	43.5	46	48.5	mV
<b>Over current limiter circuit block2</b>						
Reference current	I <sub>LIM</sub>		-10%	20	+10%	μA
Over current detection comparator 2 Offset voltage	V <sub>LIM_OFS</sub>		-5		+5	mV
Over current detection comparator 2 common mode input voltage			V <sub>IN</sub> -0.45		V <sub>IN</sub>	V
<b>Over voltage protection circuit block1</b>						
Over voltage detection voltage	V <sub>SNS_OCP</sub>			6.7		V
Over voltage detection voltage	V <sub>SNS_COM</sub>			6.7		V
<b>Over voltage protection circuit block2</b>						
Over voltage detection voltage 2	V <sub>SDIN</sub>			0.7		V

Continued on next page.

# LV5771QA

Continued from preceding page.

Parameter	Symbol	Conditions	Ratings			Unit
			min	typ	max	
<b>Output block</b>						
Output stage ON resistance (upper side)	R <sub>ONH</sub>			5		Ω
Output stage ON resistance (lower side)	R <sub>ONL</sub>			5		Ω
Output stage ON current (upper side)	I <sub>ONH</sub>		240			mA
Output stage ON current (lower side)	I <sub>ONL</sub>		240			mA
<b>The whole device</b>						
Standby current	I <sub>CCS</sub>	EN < 1V			100	μA
Mean consumption current	I <sub>CCA</sub>	EN > 5V, No switching		3		mA

## Package Dimensions

unit : mm (typ)

3444

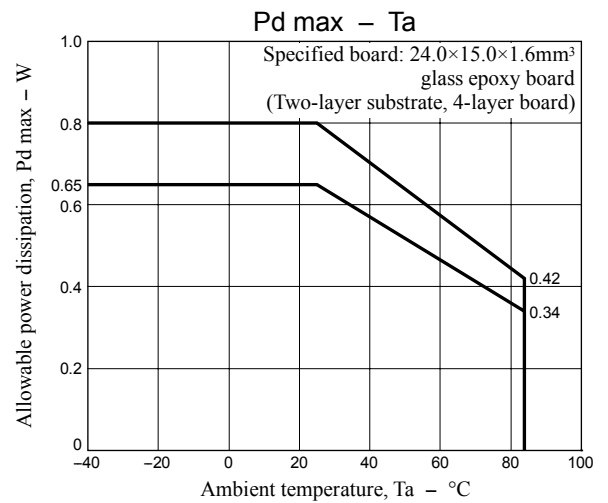
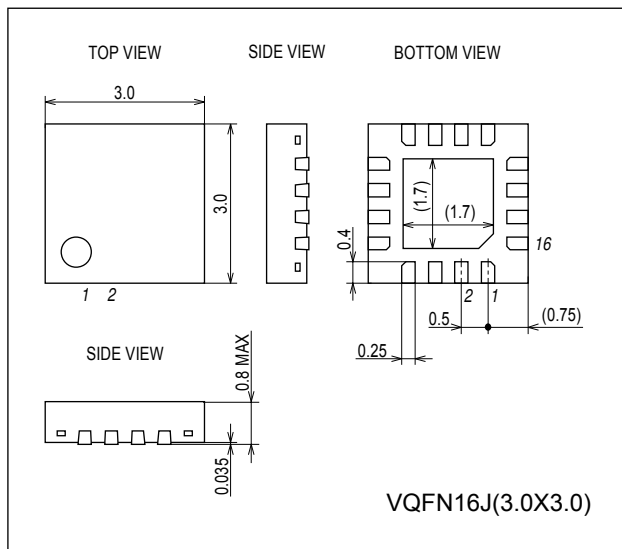

# LV5771QA

## Pin Assignment

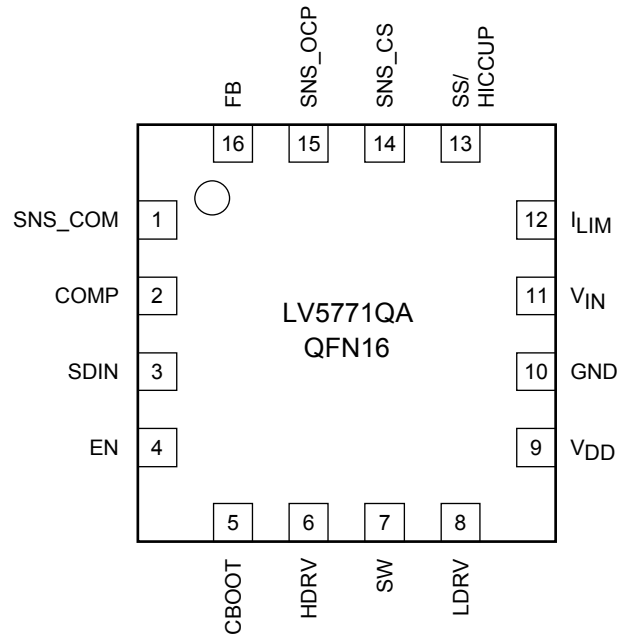

Top view

## Pin Function

No	Pin Name	Description
1	SNS_COM	Pin to connect a current sense resistor
2	COMP	Error amplifier output pin. Connect a phase compensation circuit between this pin and GND.
3	SDIN	When voltage level of this pin is High, switching is turned off. When this pin turns Low, the capacitor connected between SS/HICCUP and GND discharges voltage.
4	EN	ON/OFF pin.
5	CBOOT	Bootstrap capacity connection pin. This pin becomes a GATE drive power supply of an external NchMOSFET. Connect a bypass capacitor between CBOOT and SW.
6	HDRV	An external the upper MOSFET gate drive pin.
7	SW	Pin to connect with switching node. The source of NchMOSFET connects to this pin.
8	LDRV	An external the lower MOSFET gate drive pin.
9	VDD	Power supply pin for an external the lower MOS-FET gate drive.
10	GND	Ground pin. Each reference voltage is based on the voltage of the ground pin.
11	V <sub>IN</sub>	Power supply pin. This pin is monitored by UVLO function. When the voltage of this pin becomes 7.8V or more by UVLO function, The IC starts and the soft start function operates.
12	I <sub>LIM</sub>	Reference current pin for current detection. The sink current of about 20μA flows to this pin. When a resistance is connected between this pin and V <sub>IN</sub> outside and the voltage applied to the SW pin is lower than the voltage of the terminal side of the resistance, the upper NchMOSFET is off by operating the current limiter comparator. This operation is reset with respect to each PWM pulse.
13	SS/HICCUP	Pin to connect a capacitor for soft start. A capacitor for soft start is charged by using the voltage of about 5μA. This pin ends the soft start period by using the voltage of about 1.1V and the frequency fold back function becomes active.
14	SNS_CS	Output voltage correction rate pin.
15	SNS_OCP	Pin to connect a current sense resistor. Overcurrent protector limit function operates when the voltage of the both ends of external sense resistance exceed 46mV. When you do not use this function, make sure to connect the pin of the external sense resistance to GND.
16	FB	Error amplifier reverse input pin. By operating the converter, the voltage of this pin becomes 0.7V. The voltage in which the output voltage is divided by an external resistance is applied to this pin. Also, the oscillation frequency becomes one-tenth when the voltage of this pin becomes 0.4V or less after soft start function.

# LV5771QA

## Block Diagram

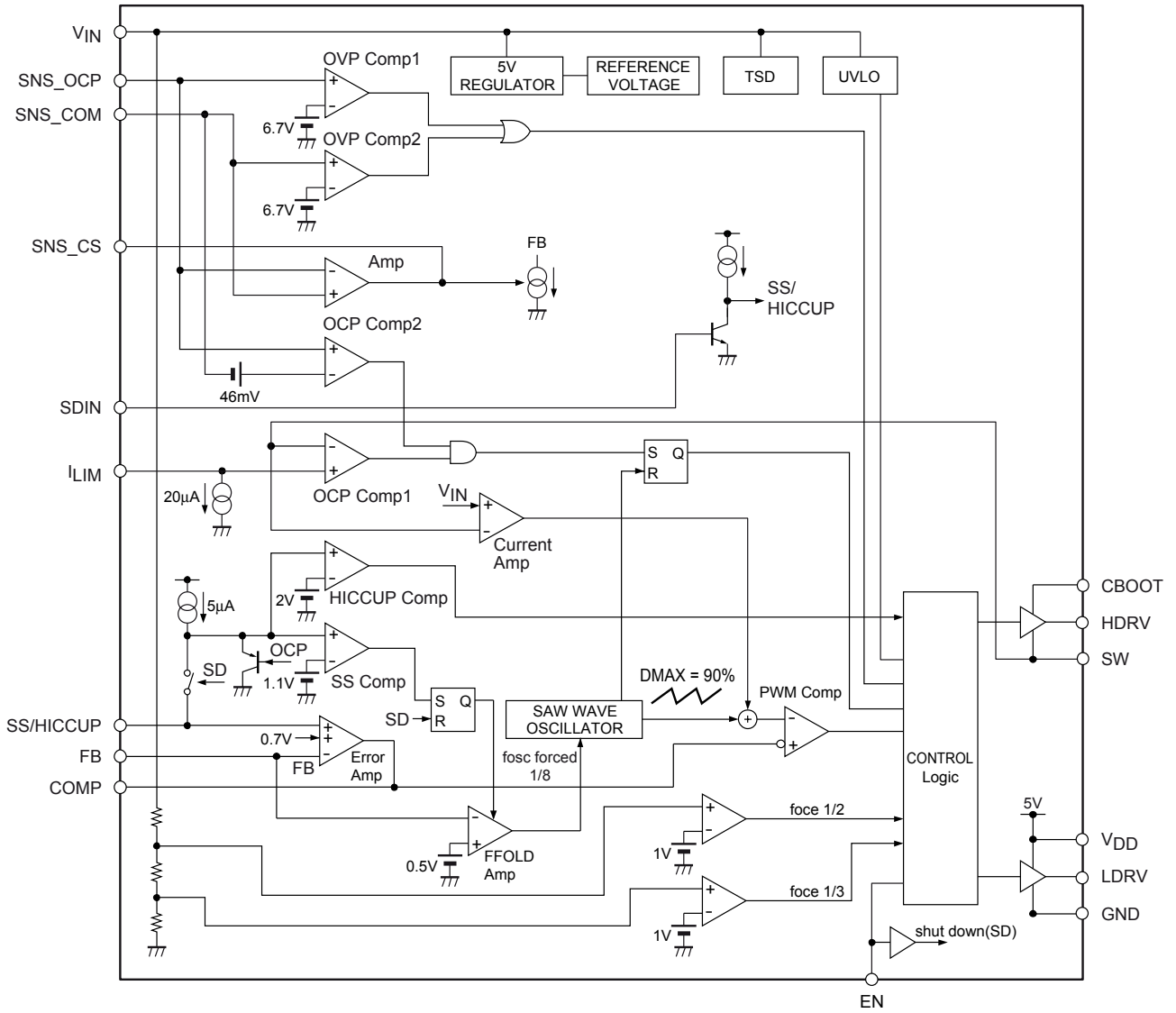

## Sample Application Circuit

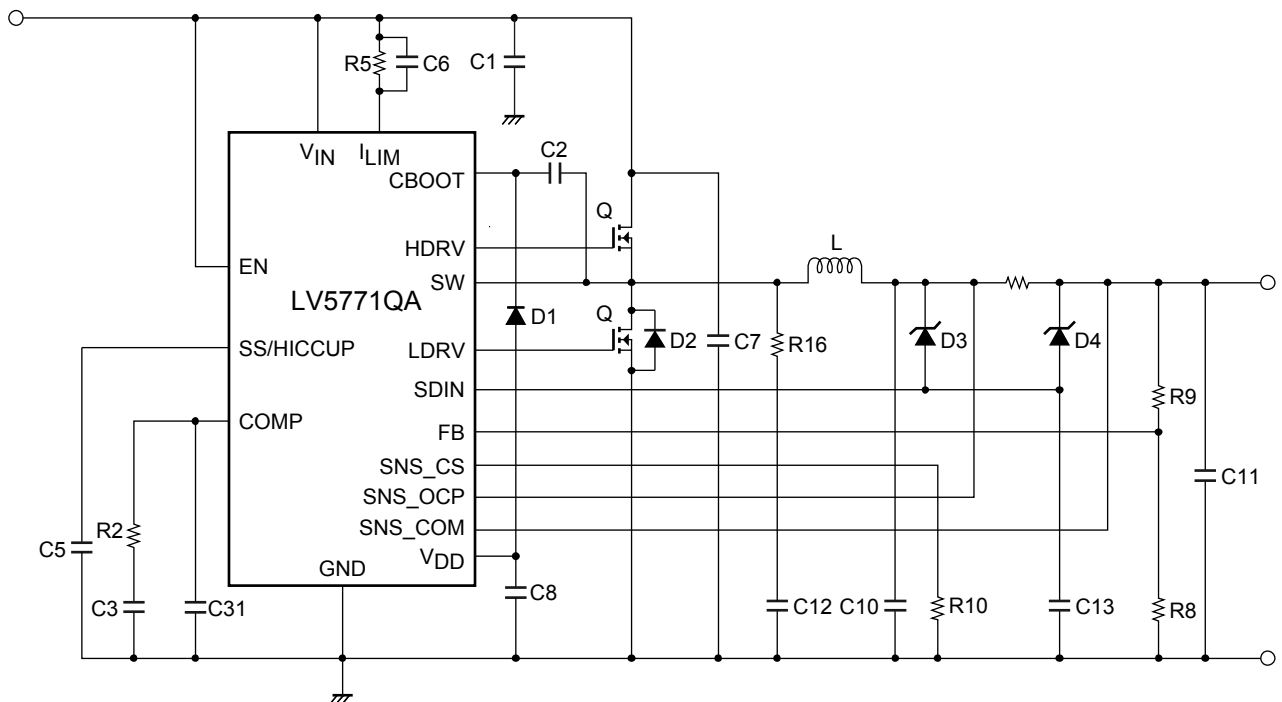

# LV5771QA

## Operating Sequence and UVLO/TSD Operation

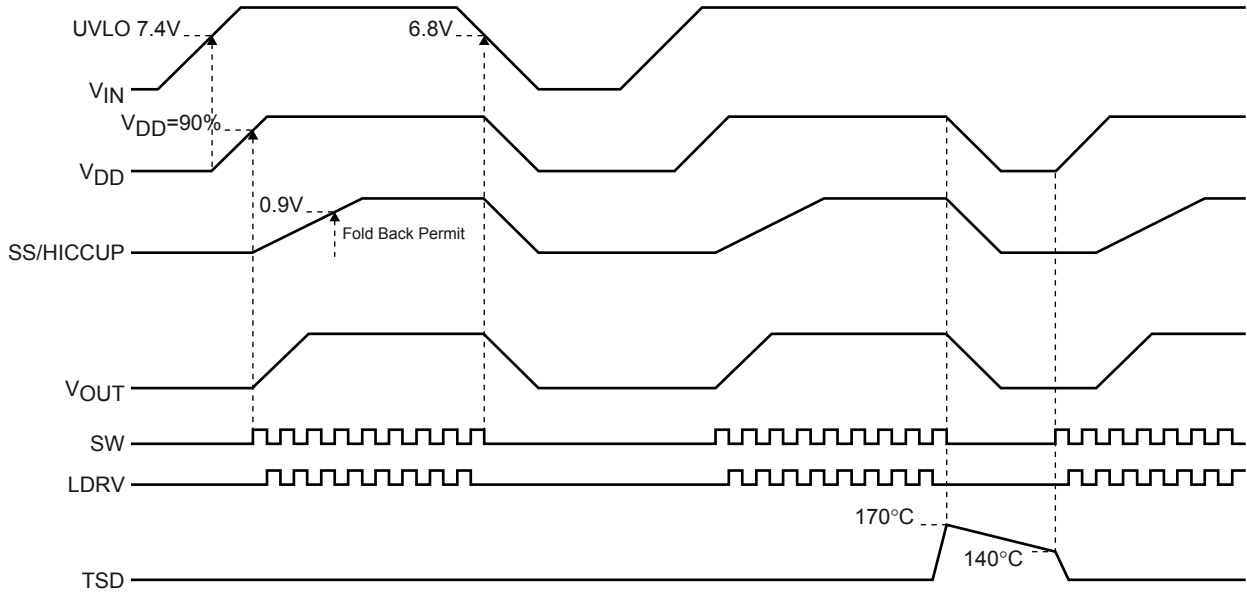

## Over Current Protection and Over Voltage Protection Sequence (ex: $V_{IN} = 12V$ , $V_{OUT} = 5V$ )

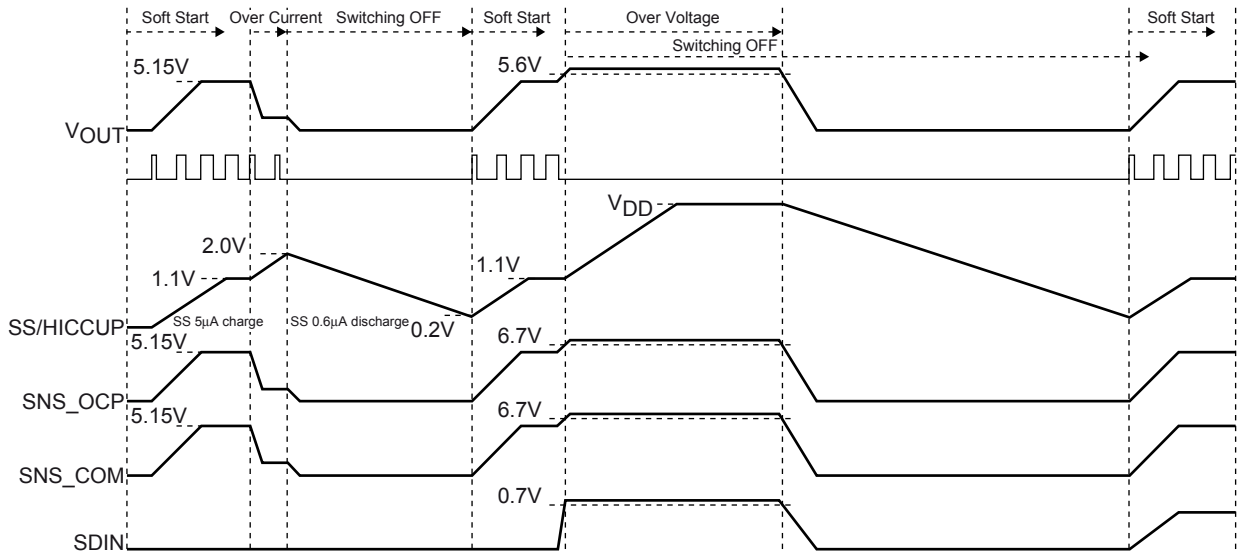

**Output Voltage correction rate**

Output voltage is increased by drawing the current proportional to the current flows along R6 (current detection resistance) from FB (error amplifier) into the IC.

Output voltage is obtained by the formula (1).

$$V_{OUT} = V_{REF} \times \left( 1 + \frac{R9}{R8} \right) + 50 \times \frac{R6 \cdot R9}{R10} \times I_{OUT} \quad (1)$$

The term that includes “I<sub>OUT</sub>” shows the increase of voltage. Voltage increase is defined by setting resistance. Cable voltage fall is easily adjustable.

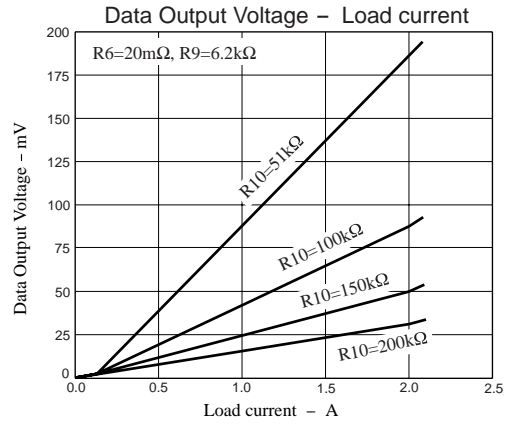

**Over current protector function**

LV5771QA integrates 2 over current protection circuits. To operate over current protector function, you need to set either one or both circuits. When 2 circuits are set, the one with lower current limiter operation point operates first.

ILIM: ILIM current value

ILmax: the maximum value of coil current,

Rdson: Ron between drain and source of Q1 (high-side Nch MOS FET). Ron of FW282 ≈ 43mΩ (when VGS = 4.5V at 25°C).

Rdson of FET has its own temperature coefficient with which resistance value increases in proportion to temperature. You need to set Rdson value against operating temperature range based on the data sheet of the FET manufacture.

**Over current protector 1**

Over current protector operates when the voltage difference of both ends is 46mV or higher due to current flows into R6 (current detection resistor). Over current limiter setting resistance R6 is obtained by the following formula (2).

$$R6 = \frac{V_{SNS\_OCP}}{I_{Lmax}} = \frac{46mV}{I_{Lmax}} \quad (2)$$

Ex) To obtain load current of 2.3A (peak current of coil) for the current limiter operating point, R6 = 20mΩ.

**Over current protector 2**

Over current protector operates when the voltage of high-side FET exceeds that of R5. Over current limiter setting resistance R5 is obtained by the following formula (3).

$$R5 = \frac{R_{DS\_ON} \times I_{Lmax}}{I_{LIM}} = \frac{R_{DS\_ON} \times I_{Lmax}}{20u} \quad (3)$$

Ex) To obtain load current of 2.3A (peak current value of coil) for the current limiter operating point, R5 = 11kΩ. Make sure to take variation by Ron (temperature change, variation) into consideration and confirm on the application board with optimal resistance value. For proper current limiter operation, connect a capacitor of 1000pF to C6 to filter undesired noise.

# LV5771QA

---

## Over voltage protector function

LV5771QA has 3 over current protection circuits. The voltage protection function operates by the internal comparator for SNS\_OCP and SNS\_COM. For SDIN, the function operates by adding zener diode between SDIN and V<sub>OUT</sub>. You need to perform either one of the settings. When 3 circuits are set, the one with lower over voltage operation point operates first.

## Over voltage protector 1

When SNS\_OCP or SNS\_COM is 6.7V or higher, HDRV signal is turned off.

## Over voltage protector 2

Make sure to connect zener diode (5.6V) between SDIN and V<sub>OUT</sub> and the capacitor of 1000pF at C13 between SDIN and GND. When SDIN is 0.7V or higher, HDRV signal is turned off.

# LV5771QA

## USB Car Charger Application Circuit

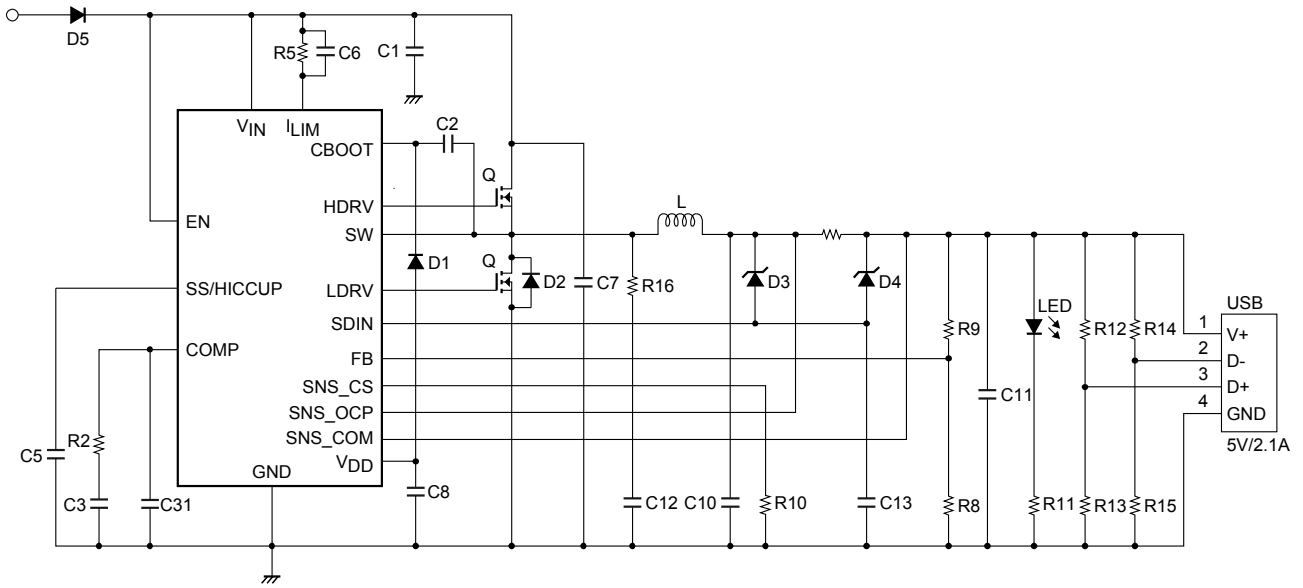

## BOM List for 5V/2.1A Car Charger

NO	REFERENCE DESIGNATOR	VALUE	PART NO.	PACKAGE	VENDER	NOTES	
1	L	3.3μH	FDV0530	6mm□	TOKO	DC Current (max) = 4.1A	
2	R2	4.7kΩ	RK73K1J	1608	KOA	J: 5%	
3	R5	11kΩ	RK73K1J	1608	KOA	J: 5%	
4	R6	20mΩ	ERJ3BWFR020V	1608	Panasonic	F: 1%	
5	R8	1kΩ	RK73K1J	1608	KOA	J: 5%	
6	R9	6.2kΩ	RK73K1J	1608	KOA	J: 5%	
7	R10	100kΩ	RK73K1J	1608	KOA	J: 5%	
8	R11	OPEN	-	-	-	-	
9	R12	OPEN	-	-	-	-	
10	R13	OPEN	-	-	-	-	
11	R14	OPEN	-	-	-	-	
12	R15	OPEN	-	-	-	-	
13	R16	4.7Ω	RK73K1J	1608	KOA	J: 5%	
14	C1	10μF	UMK325BJ	3225	TAIYO YUDEN	50Vdc, X5R	
15	C2	0.1μF	GRM188B31H	1608	Murata	25Vdc, B	
16	C3	2.7nF	GRM188B11H	1608	Murata	50Vdc, B	
17	C31	47pF	GRM1882C1H	1608	Murata	50Vdc, CH	
18	C5	0.1μF	GRM188B31H	1608	Murata	25Vdc, B	
19	C6	1000pF	GRM1882C1H	1608	Murata	50Vdc, CH	
20	C7	1000pF	GRM1882C1H	1608	Murata	50Vdc, CH	
21	C8	1μF	GRM188B10J	1608	Murata	6.3Vdc, B	
22	C10	22μF	GRM31CB30J	3216	Murata	6.3Vdc, B	
23	C11	OPEN	-	-	-	-	
24	C12	220pF	GRM1882C1H	1608	Murata	50Vdc, CH	
25	C13	1000pF	GRM1882C1H	1608	Murata	50Vdc, CH	
26	D1	-	DSE010	MCP2	SANYO	VRRM = 90V, I <sub>O</sub> = 100mA, VF = 1.2V	
27	D2	-	CRS12	S-FLAT	TOSHIBA	VRRM = 60V, I <sub>O</sub> = 1A, VF = 0.52V	
28	D3	OPEN	-	-	-	-	
29	D4	-	NSX5V6V2T1G	SOD-523	ONSEMI	5.6V±2%	
30	D5	OPEN	-	-	-	-	
31	LED	OPEN	-	-	-	-	
32	Q	-	FW217A-W	SOP8	SANYO	40V, Nch Dual type	
33	IC	-	LV5771QA	Control IC	VQFN16	SANYO	Synchronous

## Electrical Characteristics

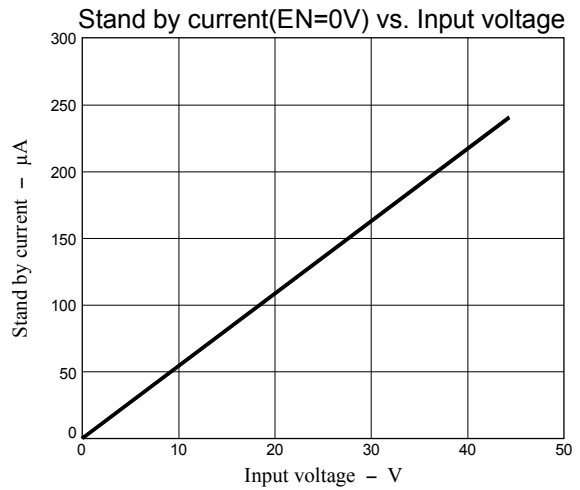
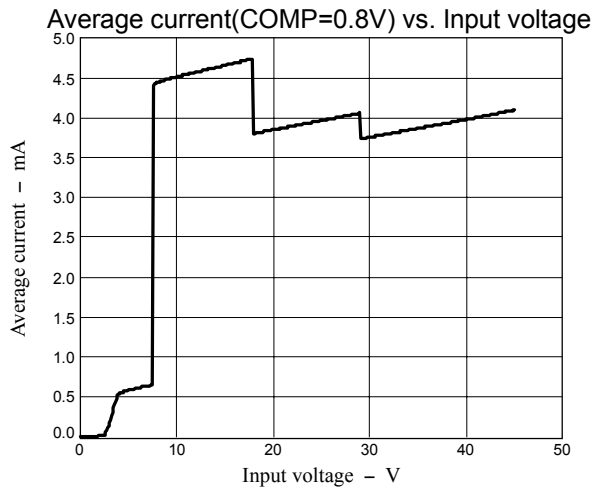
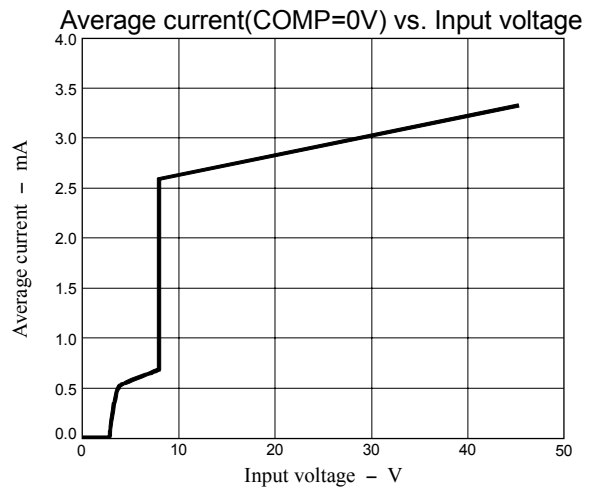
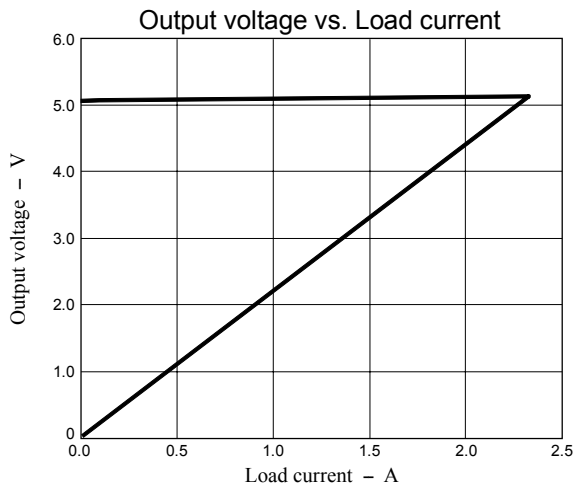
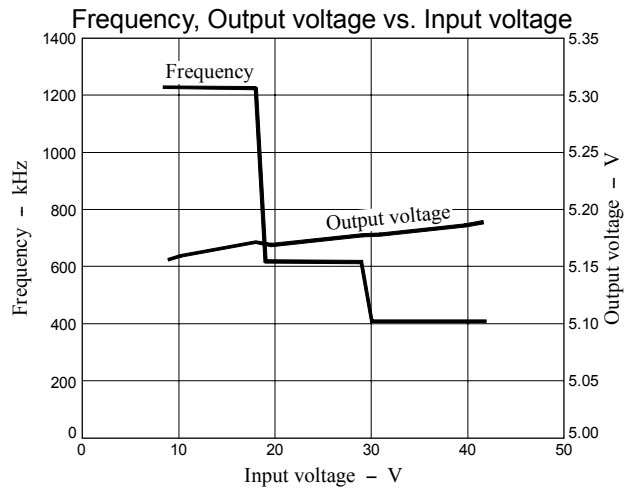
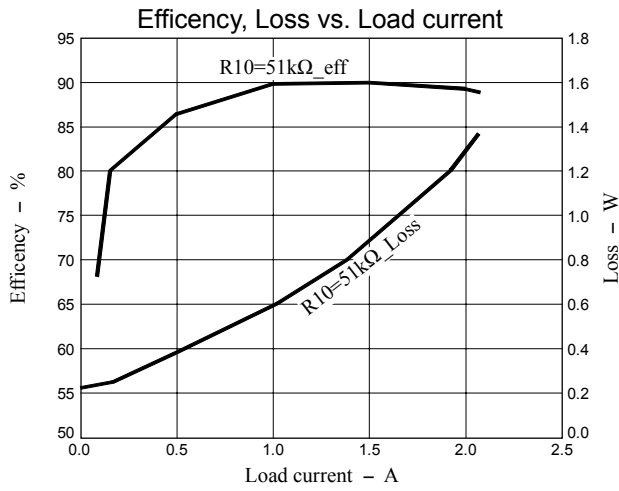

Start up Waveform  
 $V_{IN}=12V$ ,  $V_{OUT}=5V$ ,  $R_{LOAD}=2.67\Omega$

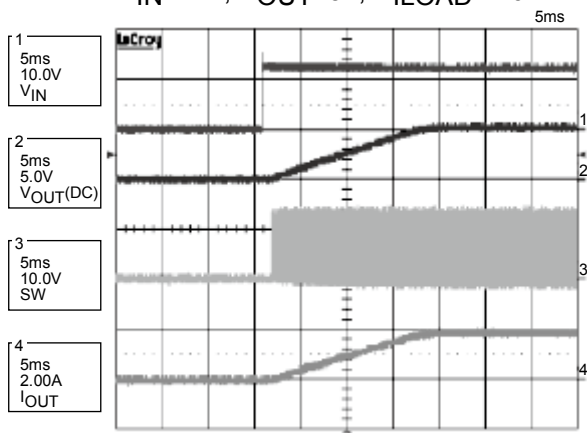

Shutdown Waveform  
 $V_{IN}=12V$ ,  $V_{OUT}=5V$ ,  $R_{LOAD}=2.67\Omega$

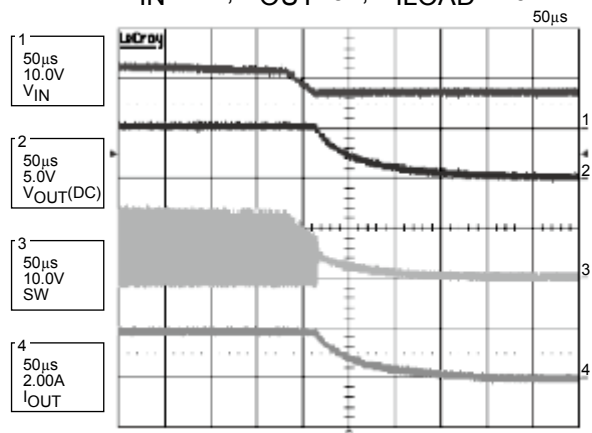

Operating Waveform  
 $V_{IN}=12V$ ,  $V_{OUT}=5V$ ,  $R_{LOAD}=2.67\Omega$

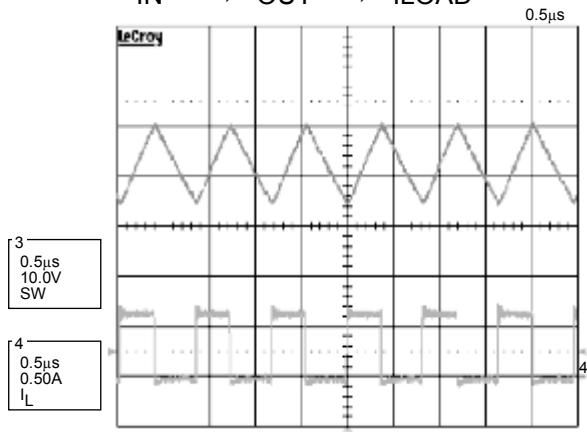

Operating Waveform  
 $V_{IN}=12V$ ,  $V_{OUT}=5V$ ,  $R_{LOAD}=2.67\Omega$

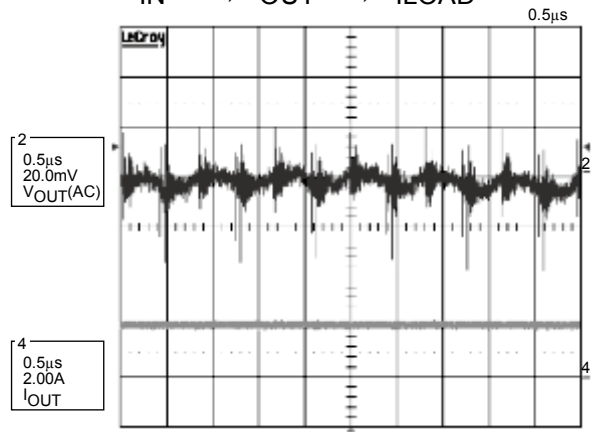

Load Step Waveform  
 $V_{IN}=12V$ ,  $V_{OUT}=5V$ ,  $I_{LOAD}=0 \leftrightarrow 2.1A/10\mu s$

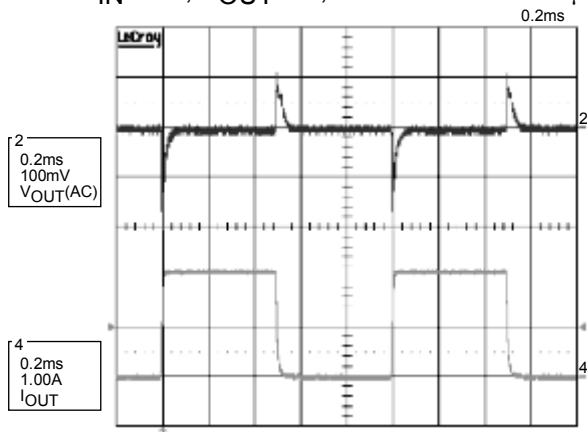

# LV5771QA

---

## ORDERING INFORMATION

Device	Package	Shipping (Qty / Packing)
LV5771QA-NH	VQFN16J(3.0x3.0) (Pb-Free / Halogen Free)	2000 / Tape & Reel
LV5771QA-2H	VQFN16J(3.0x3.0) (Pb-Free / Halogen Free)	490 / tray

ON Semiconductor and the ON logo are registered trademarks of Semiconductor Components Industries, LLC (SCILLC). SCILLC owns the rights to a number of patents, trademarks, copyrights, trade secrets, and other intellectual property. A listing of SCILLC's product/patent coverage may be accessed at [www.onsemi.com/site/pdf/Patent-Marking.pdf](http://www.onsemi.com/site/pdf/Patent-Marking.pdf). SCILLC reserves the right to make changes without further notice to any products herein. SCILLC makes no warranty, representation or guarantee regarding the suitability of its products for any particular purpose, nor does SCILLC assume any liability arising out of the application or use of any product or circuit, and specifically disclaims any and all liability, including without limitation special, consequential or incidental damages. "Typical" parameters which may be provided in SCILLC data sheets and/or specifications can and do vary in different applications and actual performance may vary over time. All operating parameters, including "Typicals" must be validated for each customer application by customer's technical experts. SCILLC does not convey any license under its patent rights nor the rights of others. SCILLC products are not designed, intended, or authorized for use as components in systems intended for surgical implant into the body, or other applications intended to support or sustain life, or for any other application in which the failure of the SCILLC product could create a situation where personal injury or death may occur. Should Buyer purchase or use SCILLC products for any such unintended or unauthorized application, Buyer shall indemnify and hold SCILLC and its officers, employees, subsidiaries, affiliates, and distributors harmless against all claims, costs, damages, and expenses, and reasonable attorney fees arising out of, directly or indirectly, any claim of personal injury or death associated with such unintended or unauthorized use, even if such claim alleges that SCILLC was negligent regarding the design or manufacture of the part. SCILLC is an Equal Opportunity/Affirmative Action Employer. This literature is subject to all applicable copyright laws and is not for resale in any manner.