



SANYO Semiconductors

DATA SHEET

LV5068V Bi-CMOS IC

Low power consumption and high efficiency Step-down Switching Regulator Controller

Overview

LV5068V is 1ch step-down switching regulator. The operation current is about 80 μ A, and low power consumption is achieved.

Functions

- 1ch SBD rectification controller IC
- Maximum value of light load mode current is 80 μ A.
- Built-in OCP circuit with P-by-P method
- When P-by-P is generated continuously, it shifts to the HICCUP operation.
- If connect C-HICCUP to GND pin, then latch-off when over current.
- The oscillatory frequency can be set by the external pin. The oscillatory frequency is 300 kHz to 2.2MHz
- Built-in UVLO, TSD
- Synchronous driving with external signal

Specifications

Maximum Ratings at Ta = 25°C

Parameter	Symbol	Conditions	Ratings	Unit
Input voltage	V _{IN} max		45	V
Allowable pin voltage	PDR,HDRV,RSNS, ILIM,EN,PG		V _{IN}	V
	V _{IN} -PDR		6	V
	REF		6	V
	SS,FB,COMP,RT C-HICCUP,SYNC		REF	V
Allowable power dissipation	Pd max	Specified substrate *1	0.74	W
Operating temperature	Topr		-40 to +85	°C
Storage temperature	Tstg		-55 to +150	°C

*1: Specified substrate 114.3mm×76.1mm×1.6mm³ glass-epoxy

■ Any and all SANYO Semiconductor Co.,Ltd. products described or contained herein are, with regard to "standard application", intended for the use as general electronics equipment (home appliances, AV equipment, communication device, office equipment, industrial equipment etc.). The products mentioned herein shall not be intended for use for any "special application" (medical equipment whose purpose is to sustain life, aerospace instrument, nuclear control device, burning appliances, transportation machine, traffic signal system, safety equipment etc.) that shall require extremely high level of reliability and can directly threaten human lives in case of failure or malfunction of the product or may cause harm to human bodies, nor shall they grant any guarantee thereof. If you should intend to use our products for applications outside the standard applications of our customer who is considering such use and/or outside the scope of our intended standard applications, please consult with us prior to the intended use. If there is no consultation or inquiry before the intended use, our customer shall be solely responsible for the use.

■ Specifications of any and all SANYO Semiconductor Co.,Ltd. products described or contained herein stipulate the performance, characteristics, and functions of the described products in the independent state, and are not guarantees of the performance, characteristics, and functions of the described products as mounted in the customer's products or equipment. To verify symptoms and states that cannot be evaluated in an independent device, the customer should always evaluate and test devices mounted in the customer's products or equipment.

SANYO Semiconductor Co., Ltd.

<http://semicon.sanyo.com/en/network>

LV5068V

Recommended Operating Conditions at Ta = 25°C

Parameter	Symbol	Conditions	Ratings	Unit
Input voltage range	V _{IN}		4.5 to 40	V

Electrical Characteristics at Ta = 25°C, V_{IN} = 15V

Parameter	Symbol	Conditions	Ratings			Unit
			min	typ	max	
Reference voltage						
Internal reference voltage	V _{ref}		1.241	1.260	1.279	V
Pch drive voltage	V _{PDR}	I _{OUT} =0 to -5mA	V _{IN} -5.5	V _{IN} -5.0	V _{IN} -4.5	V
Saw wave oscillator						
Oscillatory frequency	F _{OSC}	RT=470kΩ	280	330	380	kHz
ON/OFF circuit						
IC start-up voltage	V _{CNT_ON}		1.5		V _{IN}	V
Disable voltage	V _{CNT_OFF}		0		0.3	V
Soft start circuit						
Soft start source current	I _{SS_SC}	EN>1.5V	1.3	2.0	2.7	μA
Soft start sink current	I _{SS_SK}	EN<0.3V, SS=4V	1.0	1.6	2.2	mA
UVLO circuit						
UVLO release voltage	V _{UVLON}	FB=COMP	3.3	3.7	4.1	V
UVLO lock voltage	V _{UVLOF}	FB=COMP	2.5	2.9	3.3	V
Error amplifier						
Input bias current	I _{EA_IN}		-100	-50	100	nA
Error amplifier gain	G _{EA}		100	250	400	μA/V
Output sink current	I _{EA_OSK}	FB=1.75V	-40	-20	-10	μA
Output source current	I _{ES_OSC}	FB=0.75V	10	20	40	μA
Over current limit circuit						
Reference current	I _{LIM1}		48.4	55	61.6	μA
Over current detection comparator offset voltage	V _{LIM_OFS}		-5		+5	mV
RSNS pin input range	V _{RSNS}		V _{IN} -0.175		V _{IN}	V
HICCUP timer start-up cycle	N _L CYCLES			15		cycle
HICCUP comparator threshold voltage	V _{tHIC}		1.2	1.26	1.32	V
HICCUP timer change current	I _{HIC}		1	2	3	μA
PWM comparator						
Maximum On-duty	D max		95			%
Logic output						
Power good "L" sink current	I _{PWRGD_L}	PG=5V	4	5	6	mA
Power good "H" leakage current	I _{PWRGD_H}	PG=5V	0		1	μA
Power good threshold voltage	V _{tPG}		1.0	1.1	1.2	V
Power good hysteresis	V _{PG_H}		40	50	60	mV
Output						
Output on-resistance (High)	R _{ONH}			3		Ω
Output on-resistance (Low)	R _{ONL}			3		Ω
Output on-current (High)	I _{ONH}		500			mA
Output on-current (Low)	I _{ONL}		500			mA
The entire device						
Stand-by current	I _{CCS}	EN<0.3V	0		1	μA
Light load mode consumption current	I _{SLEEP1}	EN>1.5V, No switching	30	55	80	μA
Thermal shutdown	TSD	*2	150	170	190	°C

*2: Design certification

LV5068V

Pin Assignment

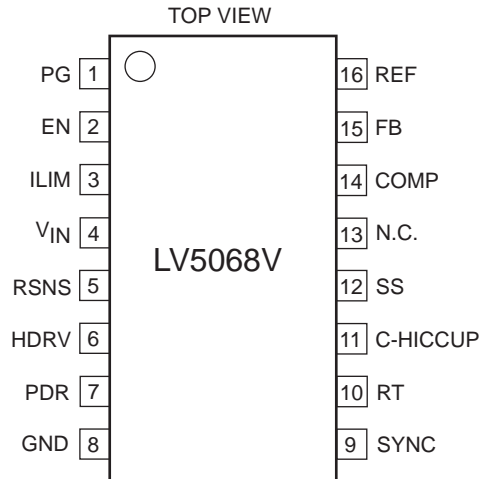

Pin Descriptions

Pin No.	Pin name	Descriptions	Equivalent circuit
1	PG	Power good pin. Connect to open drain of MOS-FET in ICs inside. Setting output voltage to "L", when FB voltage is 1.05V or less	
2	EN	ON/OFF pin	
3	ILIM	For current detection. Sink current is about 55μA. The current limiter comparator works when an external resistor is connected between this pin and V _{IN} , and if the voltage of this resistor is less than the voltage of RSNS then Pch MOS is turned off. This operation is reset each PWM pulse.	
4	V _{IN}	Supply voltage pin. It is observed by the UVLO function. When its voltage becomes 3.7V or more, ICs startup in soft start.	
5	RSNS	Current detection resistor connection pin. Resistor is connected between V _{IN} and this pin, and the current flows to MOSFET are measured.	

Continued on next page.

LV5068V

Continued from preceding page.

Pin No.	Pin name	Descriptions	Equivalent circuit
6	HDRVV	The external high-side MOSFET gate drive pin.	
7	PDR	Gate drive voltage of the external Pch MOSFET. Meanwhile, the bypass capacitor is connected between V_{IN} and this pin.	
8	GND	Ground Pin. Ground pin voltage is reference voltage.	
9	SYNC	Pin of using combined of external synchronous signal input pin	
10	RT	Oscillation frequency setting pin. Resistor is connected between this pin and GND.	
11	C-HICCUP	It is capacitor connection pin for setting re-startup cycle in HICCUP mode. If connect it to GND pin, then latch-off when over current.	
12	SS	Capacitor connection pin for soft start. About 2μA current charges the soft start capacitor.	
13	NC	NC pin.	

Continued on next page.

LV5068V

Continued from preceding page.

Pin No.	Pin name	Descriptions	Equivalent circuit
14	COMP	<p>Error Amplifier Output Pin.</p> <p>The phase compensation network is connected between GND pin and COMP pin.</p> <p>Thanks to current-mode control, COMP pin voltage would tell you the output current amplitude. COMP pin is connected internally to an int.comparator which comparators with 0.9V reference. If COMP pin voltage is larger than 0.9V, IC operates in "continuous mode". If COMP pin voltage is smaller than 0.9V, IC operates in "discontinuous mode (low consumption mode)".</p>	
15	FB	<p>Error amplifier reverse input pin.</p> <p>ICs make its voltage keep 1.26V. Output voltage is divided by external resistors and it across FB.</p>	
16	REF	<p>Reference voltage.</p>	

- SANYO Semiconductor Co.,Ltd. assumes no responsibility for equipment failures that result from using products at values that exceed, even momentarily, rated values (such as maximum ratings, operating condition ranges, or other parameters) listed in products specifications of any and all SANYO Semiconductor Co.,Ltd. products described or contained herein.
- SANYO Semiconductor Co.,Ltd. strives to supply high-quality high-reliability products, however, any and all semiconductor products fail or malfunction with some probability. It is possible that these probabilistic failures or malfunction could give rise to accidents or events that could endanger human lives, trouble that could give rise to smoke or fire, or accidents that could cause damage to other property. When designing equipment, adopt safety measures so that these kinds of accidents or events cannot occur. Such measures include but are not limited to protective circuits and error prevention circuits for safe design, redundant design, and structural design.
- In the event that any or all SANYO Semiconductor Co.,Ltd. products described or contained herein are controlled under any of applicable local export control laws and regulations, such products may require the export license from the authorities concerned in accordance with the above law.
- No part of this publication may be reproduced or transmitted in any form or by any means, electronic or mechanical, including photocopying and recording, or any information storage or retrieval system, or otherwise, without the prior written consent of SANYO Semiconductor Co.,Ltd.
- Any and all information described or contained herein are subject to change without notice due to product/technology improvement, etc. When designing equipment, refer to the "Delivery Specification" for the SANYO Semiconductor Co.,Ltd. product that you intend to use.
- Information (including circuit diagrams and circuit parameters) herein is for example only; it is not guaranteed for volume production.
- Upon using the technical information or products described herein, neither warranty nor license shall be granted with regard to intellectual property rights or any other rights of SANYO Semiconductor Co.,Ltd. or any third party. SANYO Semiconductor Co.,Ltd. shall not be liable for any claim or suits with regard to a third party's intellectual property rights which has resulted from the use of the technical information and products mentioned above.

This catalog provides information as of November, 2010. Specifications and information herein are subject to change without notice.