



ON Semiconductor®

<http://onsemi.com>

LB1948MC

Monolithic Digital IC 12V Low Saturation Voltage Drive Forward/Reverse Motor Driver

Overview

The LB1948MC is a two-channel low saturation voltage forward/reverse motor driver IC. It is optimal for motor drive in 12V system products and can drive either two DC motors, one DC motor using parallel connection, or a two-phase bipolar stepping motor with 1-2 phase excitation mode drive.

Features

- Supports 12V power supply systems
- Low saturation voltage: $V_{O(sat)} = 0.5V$ (typical) at $I_O = 400mA$
- Zero current drawn in standby mode
- Braking function
- Supports parallel connection: $I_O \text{ max} = 1.6A$, $V_{O(sat)} = 0.6V$ (typical) at $I_O = 800mA$
- Built-in spark killer diode
- Built-in thermal shutdown circuit
- Miniature package: MFP-10S (6.4mm × 5.0mm)

Specifications

Absolute Maximum Ratings at $T_a = 25^\circ C$

Parameter	Symbol	Conditions	Ratings	Unit
Maximum supply voltage	$V_{CC \text{ max}}$		-0.3 to +20	V
Output voltage	V_{OUT}		-0.3 to +20	V
Input voltage	V_{IN}		-0.3 to +18	V
Ground pin source current	I_{GND}	Per channel	800	mA
Allowable power dissipation	$P_d \text{ max}$	Mounted on a specified board*	870	mW
Operating temperature	T_{opr}		-20 to +85	°C
Storage temperature	T_{stg}		-40 to +150	°C

* Specified board: 114.3mm × 76.1mm × 1.6mm, glass epoxy board.

Caution 1) Absolute maximum ratings represent the value which cannot be exceeded for any length of time.

Caution 2) Even when the device is used within the range of absolute maximum ratings, as a result of continuous usage under high temperature, high current, high voltage, or drastic temperature change, the reliability of the IC may be degraded. Please contact us for the further details.

Stresses exceeding Maximum Ratings may damage the device. Maximum Ratings are stress ratings only. Functional operation above the Recommended Operating Conditions is not implied. Extended exposure to stresses above the Recommended Operating Conditions may affect device reliability.

LB1948MC

Allowable Operating Range at Ta = 25°C

Parameter	Symbol	Conditions	Ratings	Unit
Supply voltage	VCC		2.5 to 16	V
Input high-level voltage	V _{IH}		1.8 to 10	V
Input low-level voltage	V _{IL}		-0.3 to +0.7	V

Electrical Characteristics at Ta = 25°C, VCC = 5V

Parameter	Symbol	Conditions	Ratings			Unit
			min	typ	max	
Current drain	I _{CC0}	IN1, 2, 3, 4 = 0V (Standby mode)		0.1	10	μA
	I _{CC1}	*1 (Forward or reverse mode)		15	21	mA
	I _{CC2}	*2 (Brake mode)		30	40	mA
Output saturation voltage	V _{O(sat)1}	I _{OUT} = 200mA (High Side and Low Side)		0.25	0.35	V
	V _{O(sat)2}	I _{OUT} = 400mA (High Side and Low Side)		0.50	0.75	V
Input current	I _{IN}	V _{IN} = 5V		85	110	μA
Spark Killer Diode						
Reverse current	I _{S(leak)}				30	μA
Forward voltage	V _{SF}	I _{OUT} = 400mA			1.7	V

*1:IN1/IN2/IN3/IN4=H/L/L/L or L/H/L/L or L/L/H/L or L/L/L/H.

*2:IN1/IN2/IN3/IN4=H/H/L/L or L/L/H/H.

Package Dimensions

unit : mm (typ)

3420

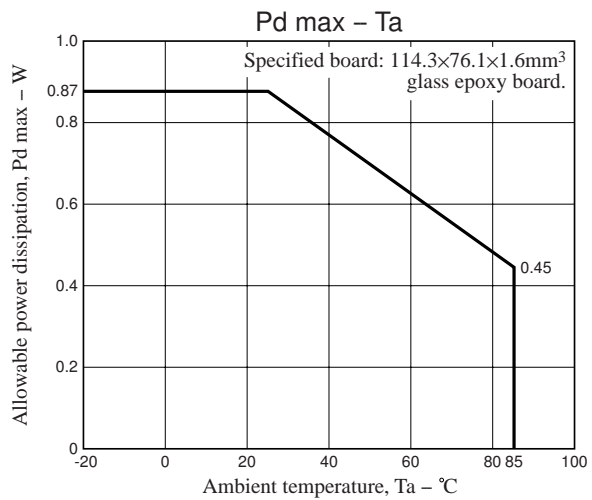
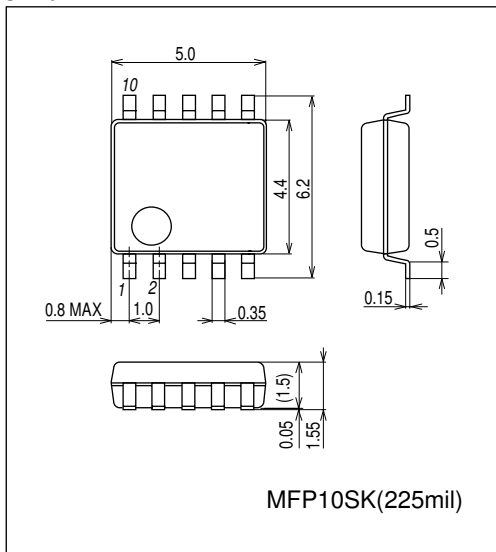

Pin Assignment

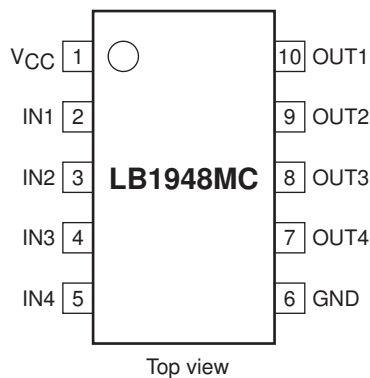

LB1948MC

Truth Table

Input				Output				Notes
IN1	IN2	IN3	IN4	OUT1	OUT2	OUT3	OUT4	
L	L	L	L	OFF	OFF	OFF	OFF	Standby mode
L	L			OFF	OFF			Standby mode
H	L			H	L			Forward
L	H			L	H			Reverse
H	H			L	L			Brake
				L	L			OFF
		H	L	H	L	Forward		
		L	H	L	H	Reverse		
		H	H	L	L	Brake		

Block Diagram

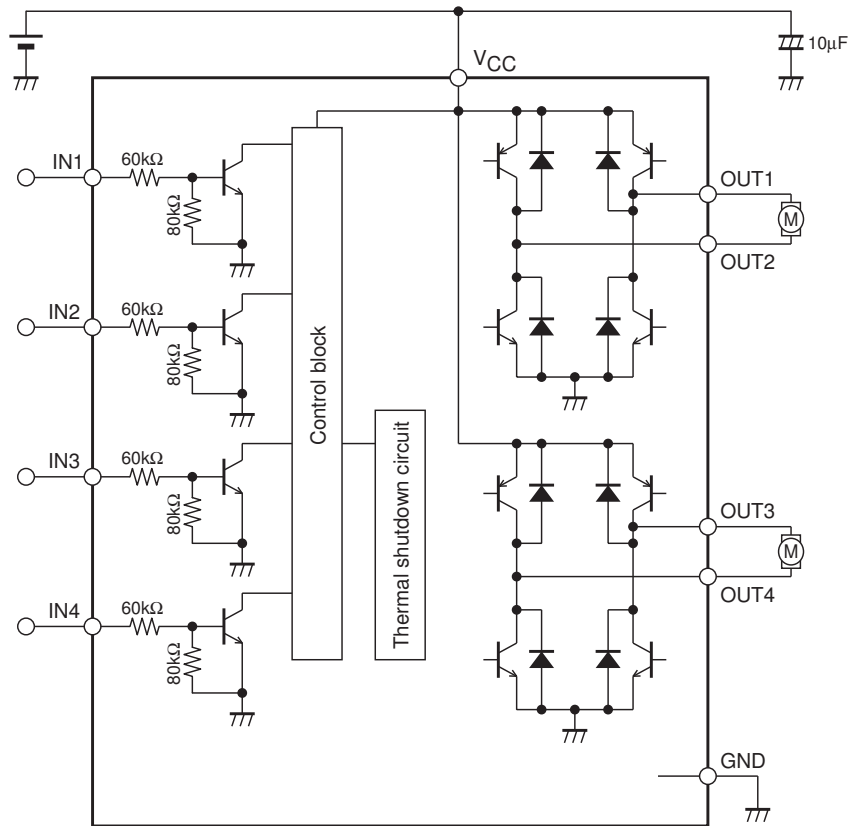

Design Documentation

(1) Voltage magnitude relationship

There are no restrictions on the magnitude relationships between the voltages applied to V_{CC} and IN1 to IN4.

(2) Parallel connection

The LB1948MC can be used as a single-channel H-bridge power supply by connecting IN1 to IN3, IN2 to IN4, OUT1 to OUT3, and OUT2 to OUT4 as shown in the figure. ($I_{Omax} = 1.6A$, $V_O(sat) = 0.6V$ (typical) at $I_O = 800mA$)

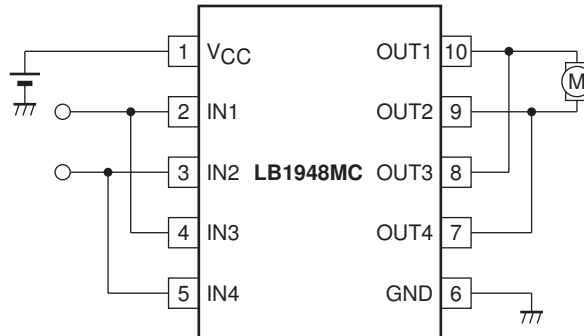

(3) Observe the following points when designing the printed circuit board pattern layout.

- Make the V_{CC} and ground lines as wide and as short as possible to lower the wiring inductance.
- Insert bypass capacitors between V_{CC} and ground mounted as close as possible to the IC.
- Resistors of about $10K\Omega$ must be inserted between the CPU output ports and the IN1 to IN4 pins if the microcontroller and the LB1948MC are mounted on different printed circuit boards and the ground potentials differ significantly.

(4) Penetration electric current

At the time of the next mode shift, a penetration electric current is generated in V_{CC} -GND. There are not the deterioration of the IC by, the destruction as follows 1A_{typ} per this penetration electric current (1ch, 1 μ s; but for the stabilization of the power supply line of the IC is most recent, and, please can enter with a condenser.

- (i) Forward (Reverse) \leftrightarrow Brake
- (ii) Forward \leftrightarrow Reverse
- (iii) Standby \rightarrow Brake

In addition, the penetration electric current disappears when I put a wait mode of 10 μ s at the time of the change of the Forward \leftrightarrow Reverse.

(5) Supplementary matter of the penetration electric current

According to (4), a penetration electric current cannot influence IC life.

Thermal Shutdown Temperature

(1) Thermal shutdown temperature

The thermal shutdown temperature T_{sd} is $200 \pm 20^\circ C$ with fluctuations.

(2) Thermal shutdown operation

The operation of the thermal shutdown circuit is shown in the figure below.

When the chip temperature T_j is in the direction of increasing (solid line), the output turns off at approximately $200^\circ C$.

When the chip temperature T_j is in the direction of decreasing (dotted line), the output turns on (returns) at approximately $125^\circ C$.

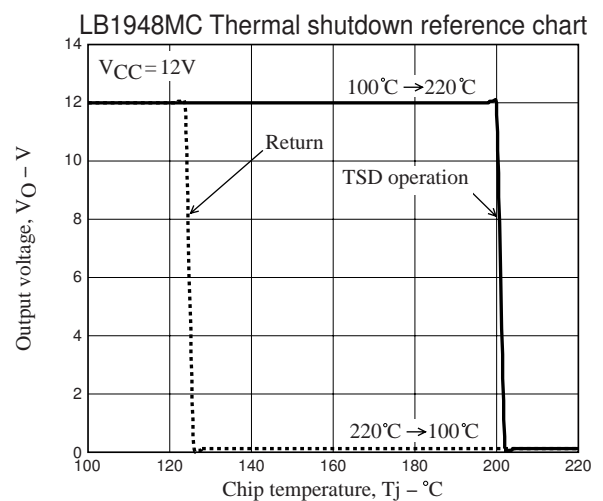

Thermal Shutdown Circuit Block Diagram

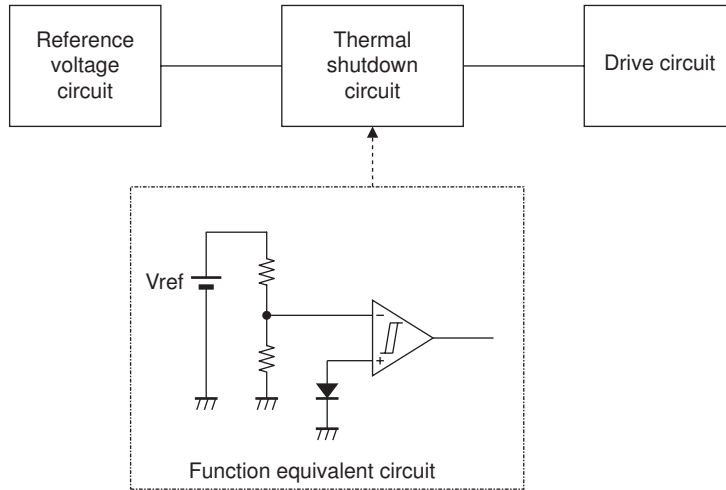

Note: The above is an example of thermal shutdown circuits although there are some differences from the actual internal circuit.

Thermal Shutdown Operation

The thermal shutdown circuit compares the voltage of the heat sensitive element (diode) with the reference voltage and shuts off the drive circuit at a certain temperature to protect the IC chip from overheating.

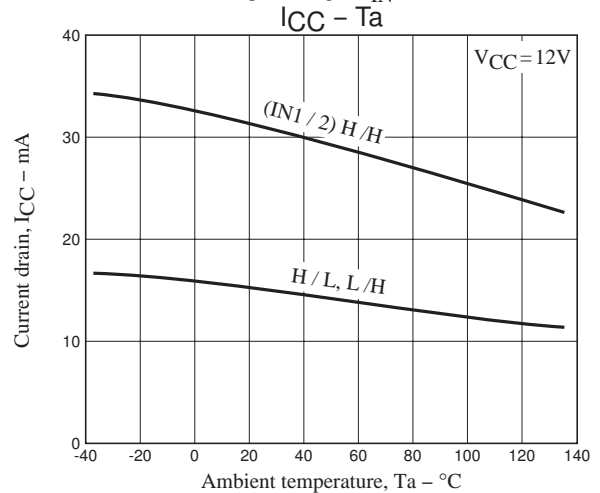
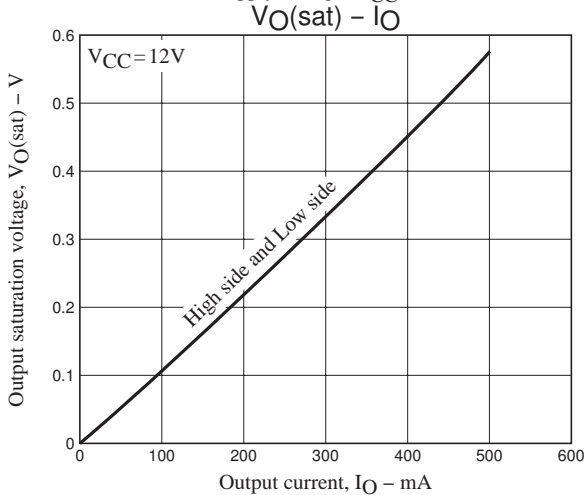
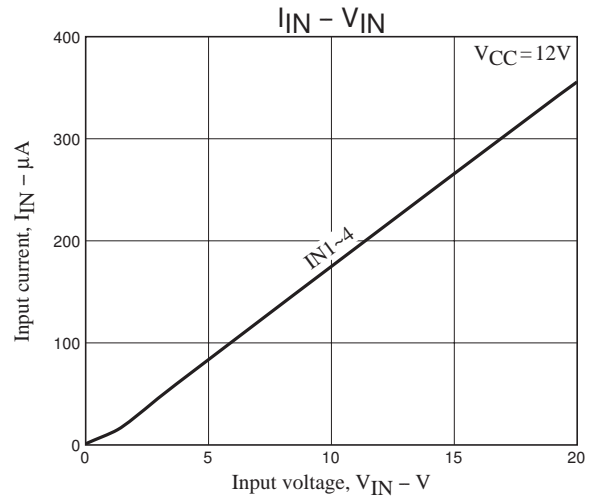
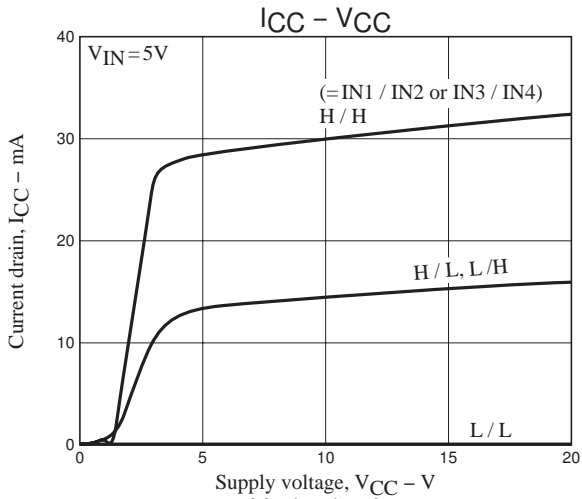

LB1948MC

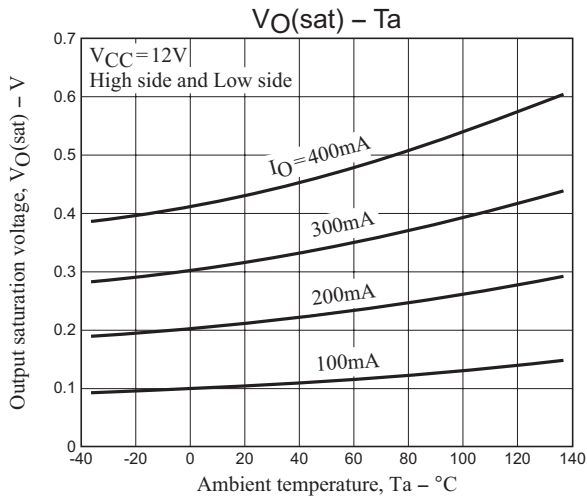

ON Semiconductor and the ON logo are registered trademarks of Semiconductor Components Industries, LLC (SCILLC). SCILLC owns the rights to a number of patents, trademarks, copyrights, trade secrets, and other intellectual property. A listing of SCILLC's product/patent coverage may be accessed at www.onsemi.com/site/pdf/Patent-Marking.pdf. SCILLC reserves the right to make changes without further notice to any products herein. SCILLC makes no warranty, representation or guarantee regarding the suitability of its products for any particular purpose, nor does SCILLC assume any liability arising out of the application or use of any product or circuit, and specifically disclaims any and all liability, including without limitation special, consequential or incidental damages. "Typical" parameters which may be provided in SCILLC data sheets and/or specifications can and do vary in different applications and actual performance may vary over time. All operating parameters, including "Typicals" must be validated for each customer application by customer's technical experts. SCILLC does not convey any license under its patent rights nor the rights of others. SCILLC products are not designed, intended, or authorized for use as components in systems intended for surgical implant into the body, or other applications intended to support or sustain life, or for any other application in which the failure of the SCILLC product could create a situation where personal injury or death may occur. Should Buyer purchase or use SCILLC products for any such unintended or unauthorized application, Buyer shall indemnify and hold SCILLC and its officers, employees, subsidiaries, affiliates, and distributors harmless against all claims, costs, damages, and expenses, and reasonable attorney fees arising out of, directly or indirectly, any claim of personal injury or death associated with such unintended or unauthorized use, even if such claim alleges that SCILLC was negligent regarding the design or manufacture of the part. SCILLC is an Equal Opportunity/Affirmative Action Employer. This literature is subject to all applicable copyright laws and is not for resale in any manner.