



ON Semiconductor®

<http://onsemi.com>

LA6585FA

Monolithic Linear IC

BTL Drive Single-Phase Full-Wave Fan Motor Driver

Overview

The LA6585FA is a single-phase bipolar fan motor driver that achieves quiet operation, power savings, silent operation and high efficiency that suppresses reactive current through BTL output linear drive. It provides lock protection and rotation signal circuits on chip, and is optimal for applications that require high reliability and low noise, such as notebook personal computers, power supplies in consumer electronic equipment, car audio, and CPU cooling systems.

Features

- BTL output single-phase full-wave linear drive (gain resistor : 1 to 360kΩ, 51dB)
- Supports low-voltage drive and features a wide usable voltage range (2.2 to 14.0V)
- Low saturation output (high side + low side saturation voltage : Vosat (total) = 1.2V (typical), IO = 250mA)
- Built-in lock protection and automatic return circuits
- Built-in FG output
- Built-in Hall sensor bias (VHB = 1.5V)
- Thermal protection circuit
- Small-sized, high thermal capacity package

Specifications

Absolute Maximum Ratings at Ta = 25°C

Parameter	Symbol	Conditions	Ratings	Unit
Supply voltage	V _{CC} max		15	V
Output current	I _{OUT} max		0.5	A
Output voltage	V _{OUT} max		15	V
FG output pin output withstand voltage	V _{FG} max		15	V
FG output current	I _{FG} max		10	mA
Allowable power dissipation	P _d max	When mounted on a circuit board *1	400	mW
Operating temperature	T _{opr}		-30 to +90	°C
Storage temperature	T _{stg}		-55 to +150	°C

*1 Specified circuit board : 114.3 × 76.1 × 1.6mm³, paper phenol.

Caution 1) Absolute maximum ratings represent the value which cannot be exceeded for any length of time.

Caution 2) Even when the device is used within the range of absolute maximum ratings, as a result of continuous usage under high temperature, high current, high voltage, or drastic temperature change, the reliability of the IC may be degraded. Please contact us for the further details.

Stresses exceeding Maximum Ratings may damage the device. Maximum Ratings are stress ratings only. Functional operation above the Recommended Operating Conditions is not implied. Extended exposure to stresses above the Recommended Operating Conditions may affect device reliability.

LA6585FA

Recommended Operating Conditions at Ta = 25°C

Parameter	Symbol	Conditions	Ratings	Unit
Supply voltage	V _{CC}		2.2 to 14.0	V
Common-phase input voltage range of hall input	V _{ICM}		0 to V _{CC} - 1.5	V

Electrical Characteristics at Ta = 25°C, V_{CC} = 12V, Unless otherwise specified.

Parameter	Symbol	Conditions	Ratings			Unit
			min	typ	max	
Circuit current	I _{CC1}	Drive mode (CT = low)	3	6	9	mA
	I _{CC2}	Lock protection mode (CT = high)	2.5	5	7.5	mA
Lock detection capacitor charge current	I _{CT1}		0.9	1.2	1.5	μA
Capacitor discharge current	I _{CT2}		0.10	0.18	0.25	μA
Capacitor charge/discharge current ratio	R _{CT}	R _{CD} = I _{CT1} /I _{CT2}	5	6.5	8	
CT charge voltage	V _{CT1}		1.3	1.5	1.7	V
CT discharge voltage	V _{CT2}		0.3	0.5	0.7	V
OUT output low saturation voltage	V _{OL}	I _O = 200mA		0.25	0.45	V
OUT output high saturation voltage	V _{OH}	I _O = 200mA		0.95	1.2	V
Hall input sensitivity	V _{HN}	Zero peak value (including offset and hysteresis)		7	15	mV
FG output pin low-level voltage	V _{FG}	I _{FG} = 5mA		0.15	0.3	V
FG output pin leakage current	I _{FGL}	V _{FG} = 15V		1	30	μA

Package Dimensions

unit : mm (typ)

3427

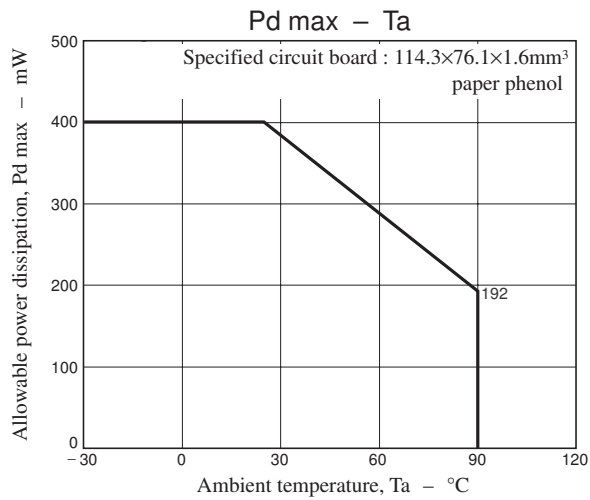
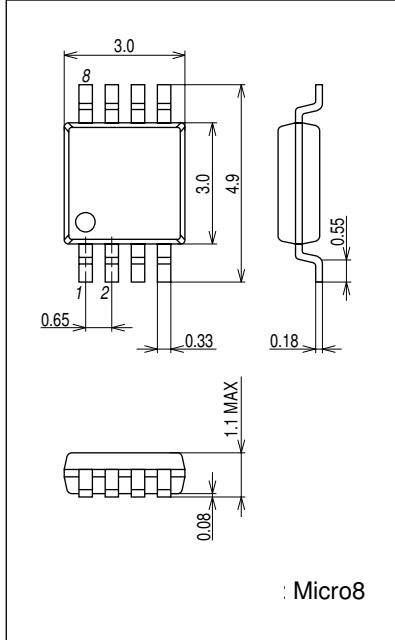

LA6585FA

Truth Table

IN-	IN+	CT	OUT1	OUT2	FG	Mode
High	Low	Low	High	Low	Low	During rotation
Low	High		Low	High	High	
-	-	High	Off	Off	-	Lock protection

Pin Assignment

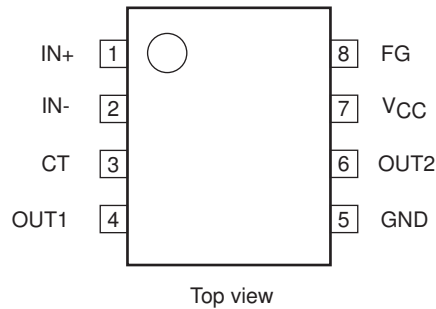

Application Circuit Example

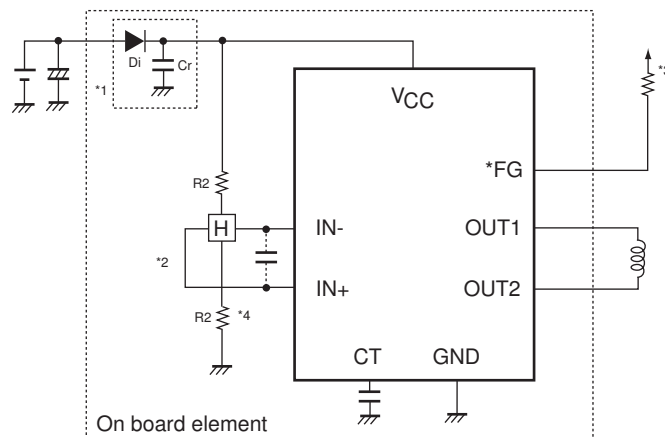

- *1. If the diode Di (which protects the IC destruction by reverse connection) is used, it is necessary to insert the capacitor Cr and provide a regenerative current route. Similarly, if there is no nearby capacitor on the fan power supply line, Cr will also be necessary to improve reliability.
- *2. If the Hall sensor bias is taken from VCC, a $1/2 V_{CC}$ bias, as shown in the figure, must be used. Linear drive is implemented by amplifying the Hall sensor output and applying voltage control to the coil. If the Hall effect sensor provides a strong output, the startup characteristics and efficiency will be good, then even quieter operation will be achieved by adjusting the Hall effect sensor.
- *3. This pin must be left open if unused.
- *4. If the line from the Hall sensor output to the Hall sensor input of IC are long, noise may enter the system from that line. If that becomes a problem, insert a capacitor as shown in the figure.

Internal Equivalent Circuits

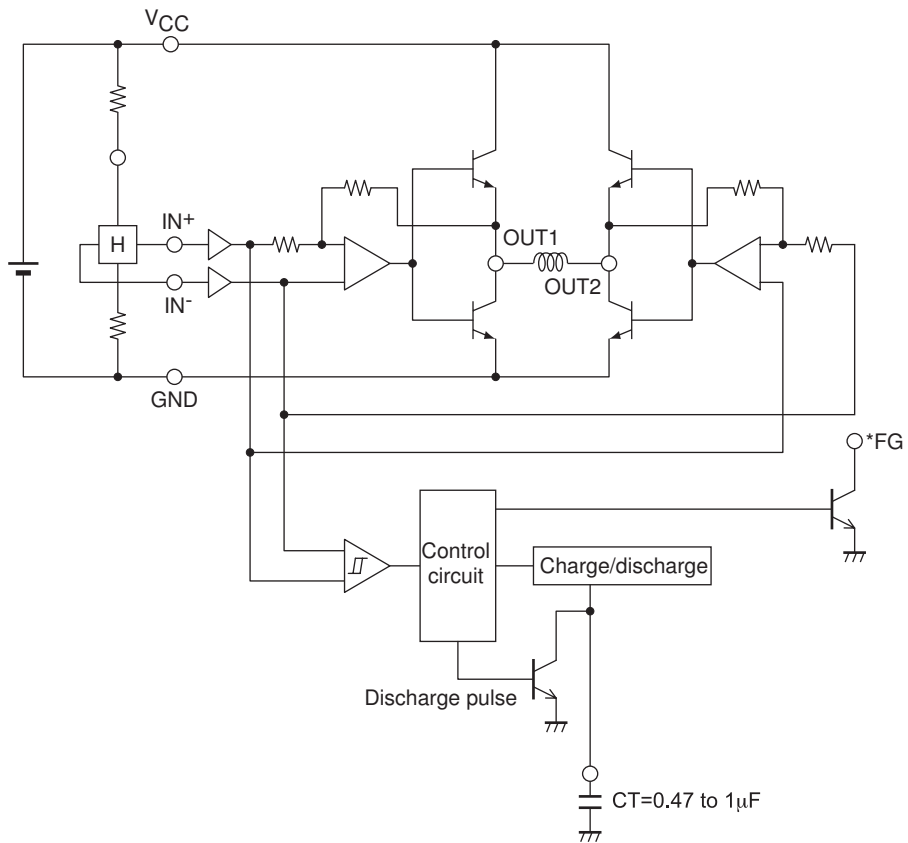

ON Semiconductor and the ON logo are registered trademarks of Semiconductor Components Industries, LLC (SCILLC). SCILLC owns the rights to a number of patents, trademarks, copyrights, trade secrets, and other intellectual property. A listing of SCILLC's product/patent coverage may be accessed at www.onsemi.com/site/pdf/Patent-Marking.pdf. SCILLC reserves the right to make changes without further notice to any products herein. SCILLC makes no warranty, representation or guarantee regarding the suitability of its products for any particular purpose, nor does SCILLC assume any liability arising out of the application or use of any product or circuit, and specifically disclaims any and all liability, including without limitation special, consequential or incidental damages. "Typical" parameters which may be provided in SCILLC data sheets and/or specifications can and do vary in different applications and actual performance may vary over time. All operating parameters, including "Typicals" must be validated for each customer application by customer's technical experts. SCILLC does not convey any license under its patent rights nor the rights of others. SCILLC products are not designed, intended, or authorized for use as components in systems intended for surgical implant into the body, or other applications intended to support or sustain life, or for any other application in which the failure of the SCILLC product could create a situation where personal injury or death may occur. Should Buyer purchase or use SCILLC products for any such unintended or unauthorized application, Buyer shall indemnify and hold SCILLC and its officers, employees, subsidiaries, affiliates, and distributors harmless against all claims, costs, damages, and expenses, and reasonable attorney fees arising out of, directly or indirectly, any claim of personal injury or death associated with such unintended or unauthorized use, even if such claim alleges that SCILLC was negligent regarding the design or manufacture of the part. SCILLC is an Equal Opportunity/Affirmative Action Employer. This literature is subject to all applicable copyright laws and is not for resale in any manner.