



ON Semiconductor®

<http://onsemi.com>

LB11852RV

Monolithic Digital IC

For Fan Motor

Single-phase Full-wave Pre-driver with Speed Control Function

Overview

The LB11852RV is a single-phase bipolar driving motor pre-driver with a speed control function based on speed feedback. With a small number of external parts, a highly efficient and very quiet variable-speed drive fan motor with low power consumption and high rotational accuracy can be implemented. The LB11852RV, integrated in a miniature package, is best suited for driving small fan motors requiring speed control.

Features

- Single-phase full-wave driving pre-driver
 - ⇒ With a PMOS-NMOS device used as the external power transistor, low saturation output and a single-phase full-wave drive enable a high-efficiency drive with low power consumption.
- Speed control circuit incorporated
 - ⇒ Compared with open-loop control, a closed-loop control function that uses speed feedback to control the speed makes it possible to improve the rotational speed accuracy and reduce the variations in the rotational speed caused by fluctuations in the supply voltage or load. The separately excited upper direct PWM method is featured as the variable speed system.
- Variable speed control is possible with external PWM input or analog voltage input
 - ⇒ The speed control input signal is compatible with PWM duty ratio and analog voltages.
- Soft start circuit incorporated
- Minimum speed setting pin
 - ⇒ The minimum speed can be set using an external resistor.
- Current limiting circuit incorporated
 - ⇒ Chopper type current limit at startup or lock.
- Reactive current cut circuit incorporated
 - ⇒ Reactive current before phase changeover is cut, ensuring highly silent and low power-consumption drive.
- Automatic resetting type constraint circuit incorporated
- RD (lock detection) output

LB11852RV

Specifications

Absolute Maximum Ratings at $T_a = 25^\circ\text{C}$

Parameter	Symbol	Conditions	Ratings	Unit
V_{CC} pin maximum supply voltage	V_{CC} max		18	V
OUTN pin maximum output current	IOUTN max		20	mA
OUTP pin maximum Sink current	IOUTP max		20	mA
OUT pin output withstand voltage	VOUT max		18	V
HB maximum output current	HB		10	mA
CTL, C pin withstand voltage	CTL, C max		7	V
CVI, LIM pin withstand voltage	CVI, LIM max		7	V
RD output pin output withstand voltage	RD max		19	V
RD output current	RD max		10	mA
5VREG pin maximum output current	I5VREG max		10	mA
Allowable power dissipation	Pd max	Mounted on a specified board *1	0.8	W
Operating temperature	Topr		-30 to 95	$^\circ\text{C}$
Storage temperature	Tstg		-55 to 150	$^\circ\text{C}$

*1 Mounted on a specified board : 114.3mm×76.1mm×1.6mm, glass epoxy

*2 T_j max = 150°C . Use the device in a condition that the chip temperature does not exceed $T_j = 150^\circ\text{C}$ during operation.

Stresses exceeding Maximum Ratings may damage the device. Maximum Ratings are stress ratings only. Functional operation above the Recommended Operating Conditions is not implied. Extended exposure to stresses above the Recommended Operating Conditions may affect device reliability.

Recommended Operating Conditions at $T_a = 25^\circ\text{C}$

Parameter	Symbol	Conditions	Ratings	Unit
V_{CC} supply voltage 1	V_{CC1}	V_{CC} pin	5.5 to 16	V
V_{CC} supply voltage 2	V_{CC2}	V_{CC} -5VREG	4.5 to 5.5	V
CTL input voltage range	VCTL		0 to 5VREG	V
LIM input voltage range	VLIM		0 to 5VREG	V
VCI input voltage range	VCVI		0 to 5VREG	V
Hall input common phase input voltage range	VICM		0.2 to 3	V

Electrical Characteristics at $T_a = 25^\circ\text{C}$, $V_{CC} = 12\text{V}$, unless otherwise specified

Parameter	Symbol	Conditions	Ratings			Unit
			min	typ	max	
Circuit current	I_{CC1}	During drive		12	15	mA
	I_{CC2}	During lock protection		12	15	mA
5VREG voltage	5VREG	I5VREG = 5mA	4.8	5.0	5.2	V
Current limiting voltage	VLIM		190	210	230	mV
CPWM pin H level voltage	V_{CRH}		2.8	3.0	3.2	V
CPWM pin L level voltage	V_{CRL}		0.9	1.1	1.3	V
CPWM pin charge current	I_{CPWM1}	$V_{CPWM} = 0.5\text{V}$	24	30	36	μA
CPWM pin discharge current	I_{CPWM2}	$V_{CPWM} = 3.5\text{V}$	21	27	33	μA
CPWM oscillation frequency	F_{PWM}	$C = 220\text{pF}$		30		kHz
CT pin H level voltage	V_{CTH}		2.8	3.0	3.2	V
CT pin L level voltage	V_{CTL}		0.9	1.1	1.3	V
CT pin charge current	I_{CT1}	$V_{CT} = 2\text{V}$	1.6	2.0	2.5	μA
CT pin discharge current	I_{CT2}	$V_{CT} = 2\text{V}$	0.16	0.20	0.25	μA
CT pin charge/discharge current ratio	R_{CT}	I_{CT1}/I_{CT2}	8	10	12	times
OUTN pin output H voltage	V_{ONH}	$I_O = 10\text{mA}$		$V_{CC}-0.85$	$V_{CC}-1.0$	V
OUTN pin output L voltage	V_{ONL}	$I_O = 10\text{mA}$		0.9	1.0	V
OUTP pin output L voltage	V_{OPL}	$I_O = 10\text{mA}$		0.5	0.65	V
Hall input sensitivity	VHN	IN^+ , IN^- differential voltage (including offset and hysteresis)		± 15	± 25	mV

Continued on next page.

LB11852RV

Continued from preceding page.

Parameter	Symbol	Conditions	Ratings			Unit
			min	typ	max	
RD output L voltage	VRDL	IRD = 5mA		0.15	0.30	V
RD pin leak current	IRDL	VRD = 19V			30	μA
EO pin output H voltage	VEOH	IEO1 = -0.2mA	VREG-1.2	VREG-0.8		V
EO pin output L voltage	VEOL	IEO1 = 0.2mA		0.8	1.1	V
RC pin output H voltage	V _{RC} H		3.2	3.45	3.7	V
RC pin output L voltage	V _{RC} L		0.7	0.8	1.05	V
RC pin clamp voltage	V _{RC} CLP		1.3	1.5	1.7	V
CTL pin input H voltage	V _{CTL} H		2.0		VREG	V
CTL pin input L voltage	V _{CTL} L		0		1.0	V
CTL pin input open voltage	V _{CTL} O		VREG-0.5		VREG	V
CTL pin H input H current	I _{CTL} H	V _{CTLIN} = 5VREG	-10	0	10	μA
CTL pin L input L current	I _{CTL} L	V _{CTLIN} = 0V	-120	-90		μA
C pin output H voltage	V _C H		VREG-0.3	VREG-0.1		V
C pin output L voltage	V _C L		1.8	2.0	2.2	V
LIM pin input bias current	I _B LIM		-1		1	μA
LIM pin common phase input voltage range	V _I LIM		2.0		VREG	V
SOFT pin charge current	I _C SOFT		1.0	1.3	1.6	μA
SOFT pin operating voltage range	V _I SOFT		2.0		VREG	V

Package Dimensions

unit : mm (typ)

3360

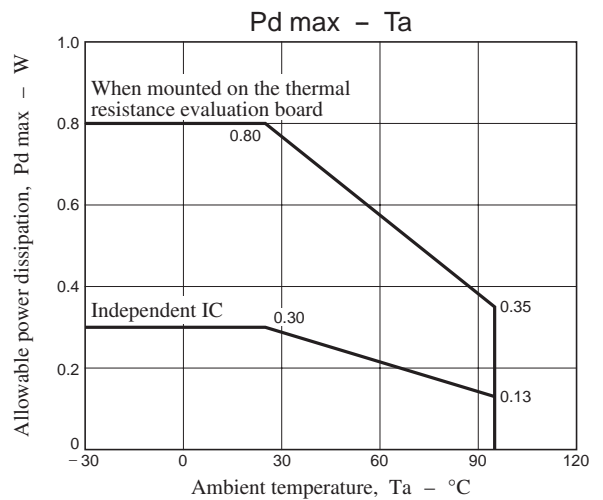
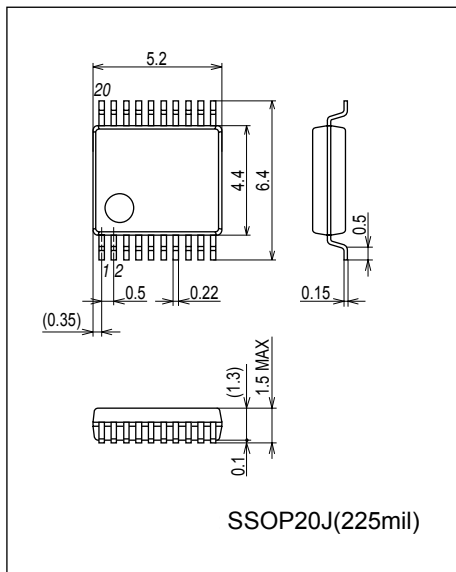

LB11852RV

Truth table

Lock protection CPWM = H

IN ⁻	IN ⁺	CT	OUT1P	OUT1N	OUT2P	OUT2N	RD	Mode
H	L	L	L	L	OFF	H	L	OUT1 → 2 drive
L	H		OFF	H	L	L	L	OUT2 → 1 drive
H	L	H	OFF	L	OFF	H	OFF	Lock protection
L	H		OFF	H	OFF	L	OFF	

Speed control CT = L

EO	CPWM	IN ⁻	IN ⁺	OUT1P	OUT1N	OUT2P	OUT2N	Mode
L	H	H	L	L	L	OFF	H	OUT1 → 2 drive
		L	H	OFF	H	L	L	OUT2 → 1 drive
H	L	H	L	OFF	L	OFF	H	Regeneration mode
		L	H	OFF	H	OFF	L	

Pin Assignment

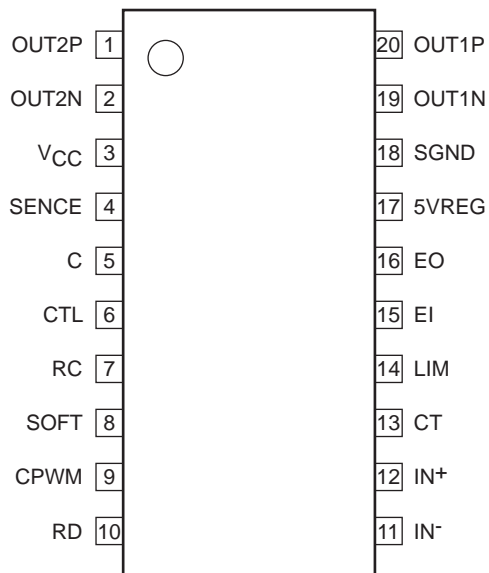

Top view

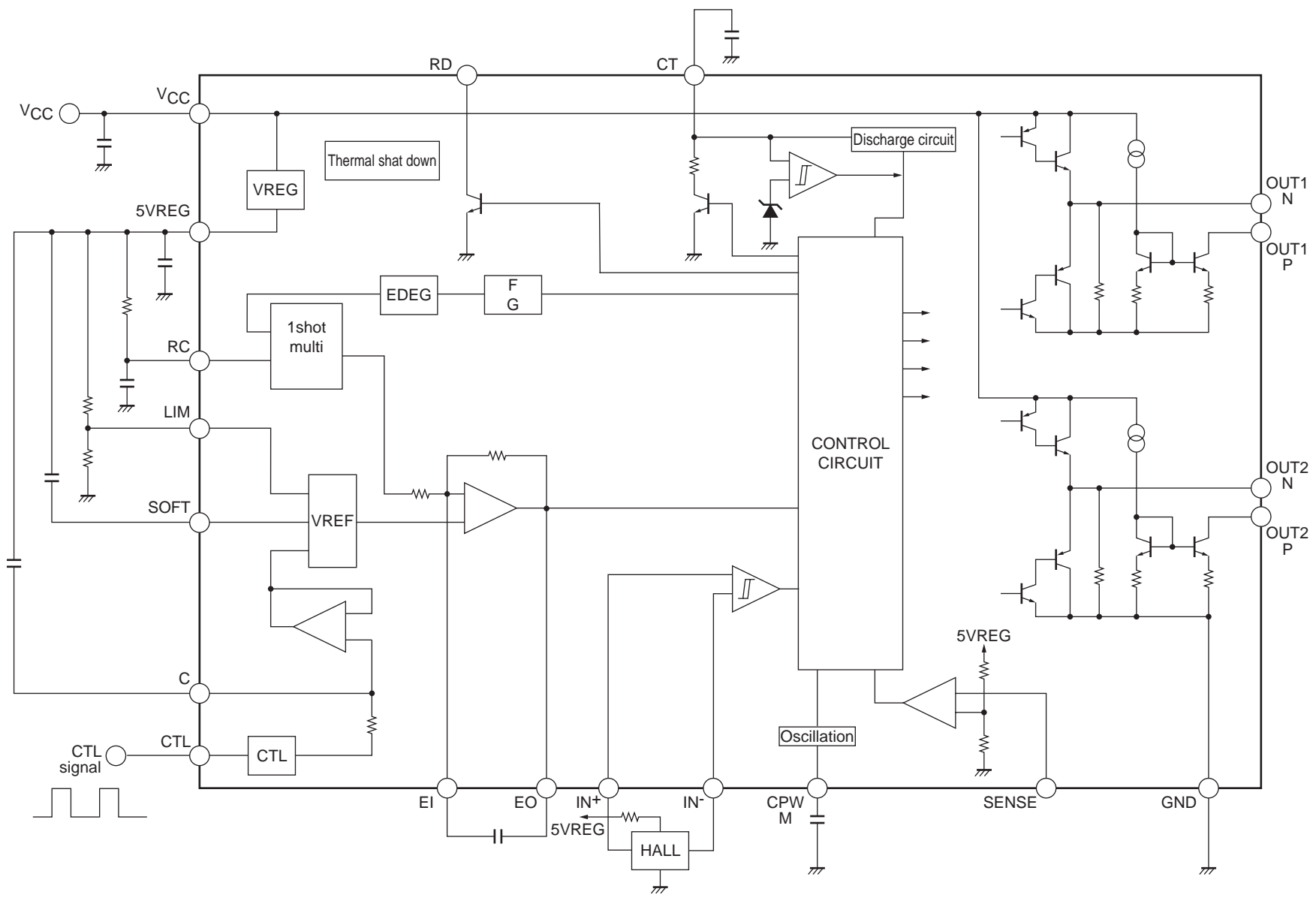

Description of Pre-driver Bock

*1 : Power-GND wiring

The SGND is connected to the control circuit power supply system.

*2 : Power stabilization capacitor

For the power stabilization capacitor on the signal side, use a capacitor of 0.1 μ F or more. Connect the capacitor between VCC and GND with a thick and along the shortest possible route.

*3 : Power-side power stabilization capacitor

For the power-side power stabilization capacitor, use a capacitor of 1 μ F or more. Connect the capacitor between the power-side power supply and GND with a thick and along the shortest possible route.

*4 : IN⁺, IN⁻ pins

Hall signal input pins

Wiring should be short to prevent noise from being carried.

If noise is carried, insert a capacitor between the IN⁺ and IN⁻ pins.

The Hall input circuit functions as a comparator with hysteresis (15mV).

It also has a soft switch zone with \pm 30mV (input signal difference voltage).

It is also recommended that the Hall input level should be a minimum of 100mV (p-p).

*5 : CPWM pin

Pin to connect the capacitor used to generate the PWM basic frequency

Use of CP = 200pF causes oscillation at f = 30kHz, which is the basic frequency of PWM.

As this is also used for the current limiter reset signal, a capacitor must be connected even if the speed is not going to be controlled.

*6 : CT pin

Pin to connect the capacitor used for lock detection

The constant-current charging and constant-current discharging circuits incorporated cause locking when the pin voltage reaches 3.0V, and releasing the lock protection when it drops to 1.0V.

Connect this pin to the GND when it is not to be used (locking not necessary).

*7 : SENSE pin

Current limiter detection pin

When the pin voltage exceeds 0.21V, the current limiter is activated, and operation enters lower regeneration mode.

Connect this pin to the GND when it is not to be used.

*8 : RD pin

Lock detection pin

This pin is open drain output. During rotation, RD pin is set to low-level voltage.

During lock detection, it is set to off.

Keep this pin open when it is not to be used.

Description of Speed Control Block

1. Speed control diagram

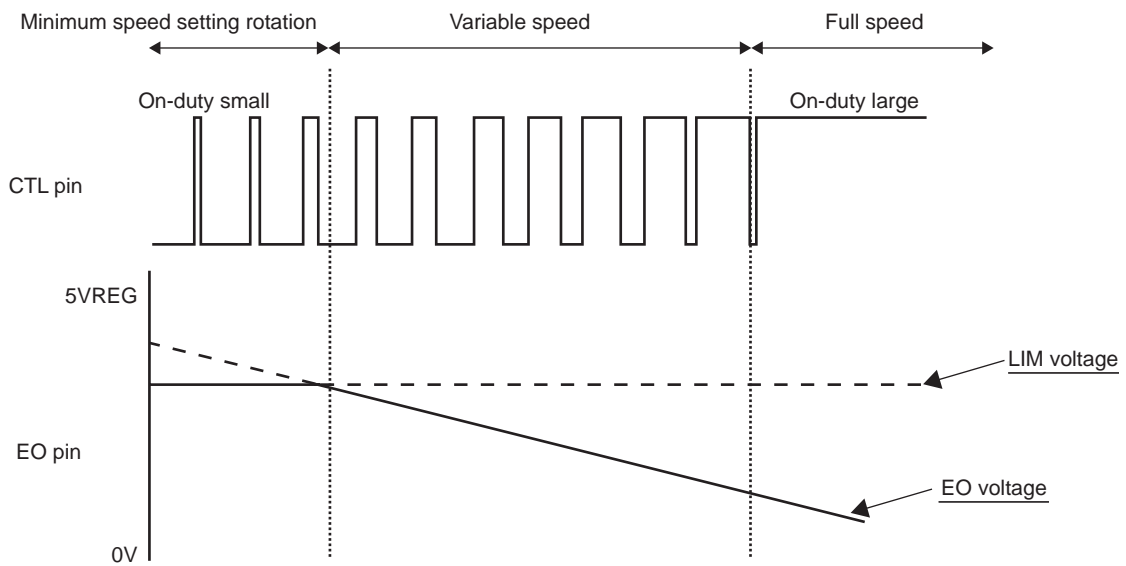
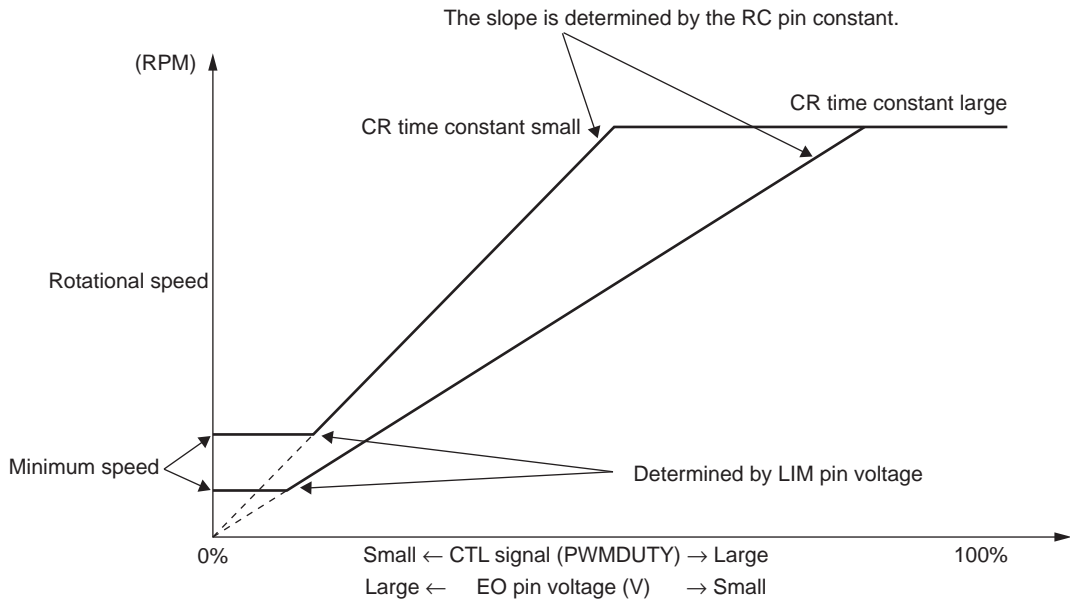

2. Timing at startup (soft start)

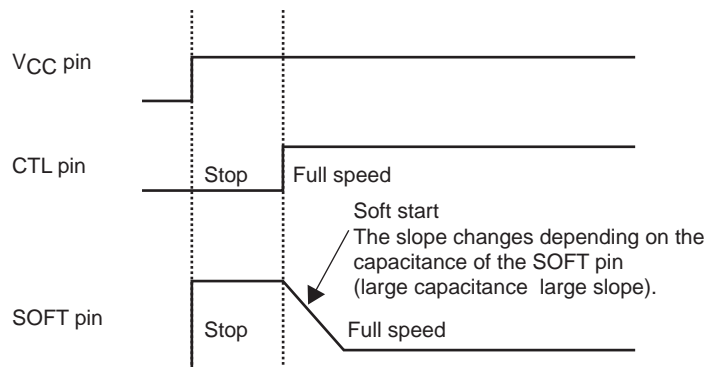

LB11852RV

2. Supplementary description of operations

By inputting the duty pulses, a feedback loop is formed inside the LB11852 RV IC to establish the FG period (rotational speed of the motor) that corresponds to the control voltage of the pulses.

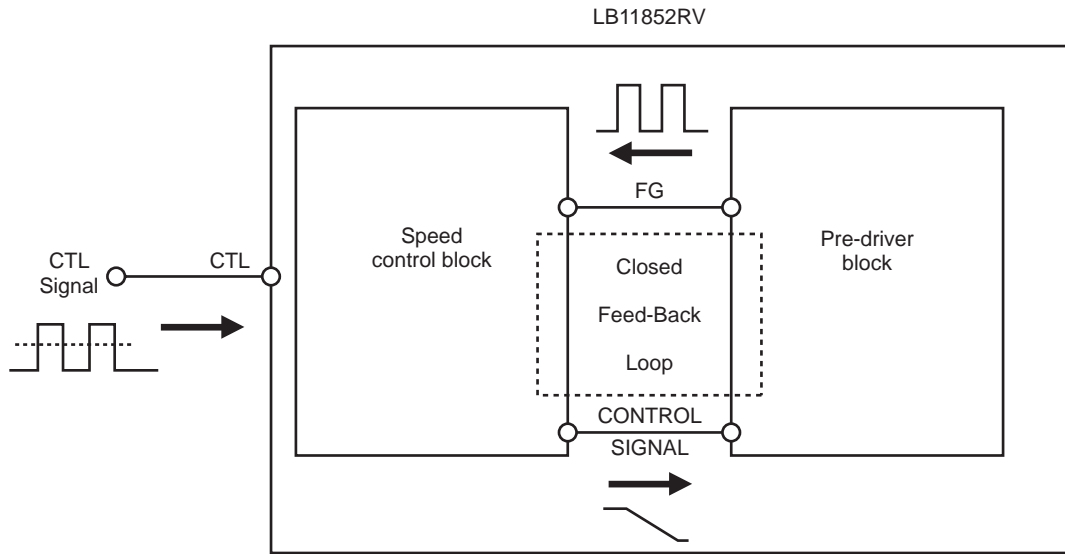

The operation inside the IC is as follows. Pulse signals are created from the edges of the FG signals as shown in the figure below, and using these signals as a reference, waveforms with a pulse width determined by the CR time constant are generated using a one-shot multivibrator. These pulse waveforms are then integrated to control the duty ratio of the pre-driver output as the control voltage.

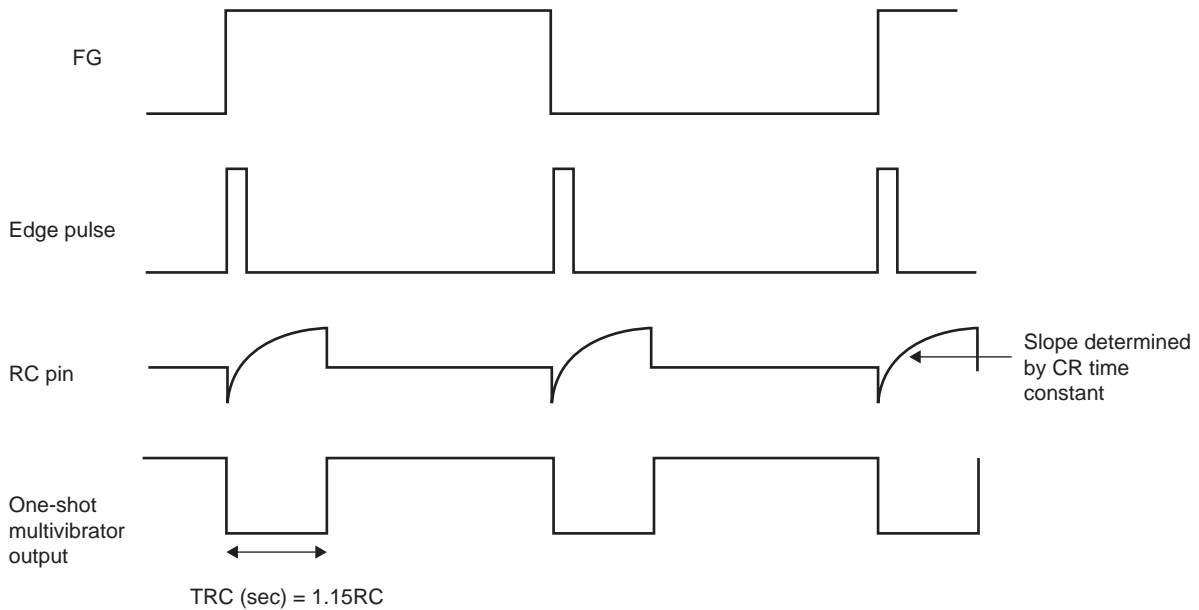

By changing the pulse width as determined by the CR time constant, the VCTL versus rotational speed slope can be adjusted as shown in the speed control diagram in the previous section.

However, since pulses that are determined by the CR time constant are used, the CR variations are output as-is as the speed control error.

4. Procedure for calculating the constant

⟨RC pin⟩

The slope shown in the speed control diagram is determined by the constant of the RC pin.

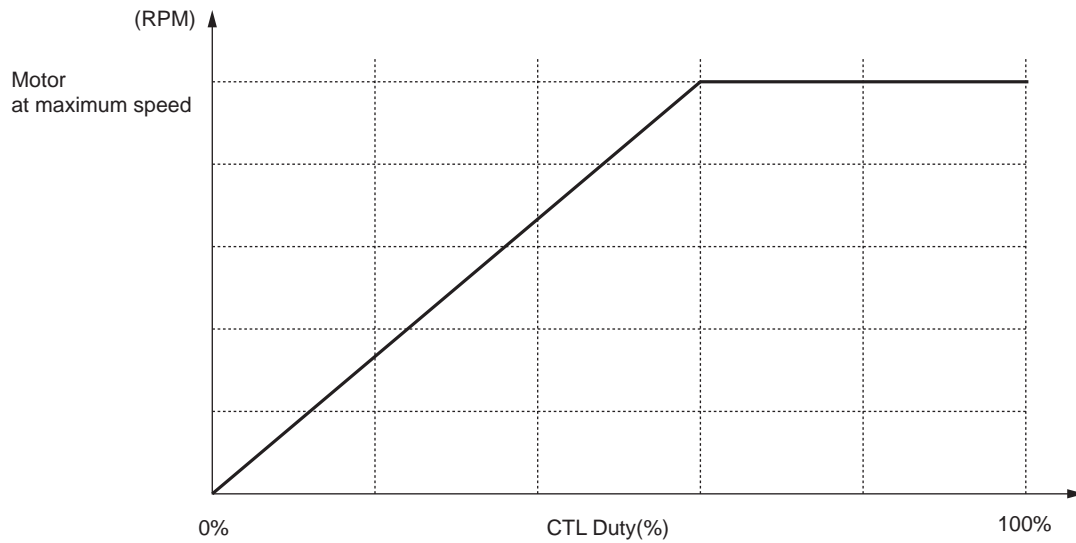

- 1) Obtain the FG signal frequency f_{FG} (Hz) at the maximum rotational speed of the motor (with two FG pulses per rotation).

$$f_{FG} \text{ (Hz)} = 2 \text{ rpm}/60 \cdots (1)$$

- 2) Obtain the time constant of the components connected to the RC pin (use the duty ratio (example : 100% = 1.0 or 60% = 0.6) as the CTL duty ratio for achieving the maximum rotational speed).

$$R \times C = \text{Duty ratio} / (3.3 \times 1.1 \times f_{FG}) \cdots (2)$$

- 3) Obtain the resistance and the capacitance of the capacitor.

Based on the discharge capability of the RC pin, the capacitance of the capacitor which can be used is in the range of $0.01\mu\text{F}$ to $0.015\mu\text{F}$.

Therefore, obtain the appropriate resistance from the result of (2) above using the formula in (3) or (4) below.

$$R = (R \times C) / 0.01\mu\text{F} \cdots (3)$$

$$R = (R \times C) / 0.015\mu\text{F} \cdots (4)$$

The temperature characteristics of the curve are determined by the temperature characteristics of the capacitor of the RC pin. To minimize the variations in the rotational speed caused by temperature, a capacitor with excellent temperature characteristics must be used.

<LIM pin>

The minimum speed is determined by the voltage of the LIM pin.

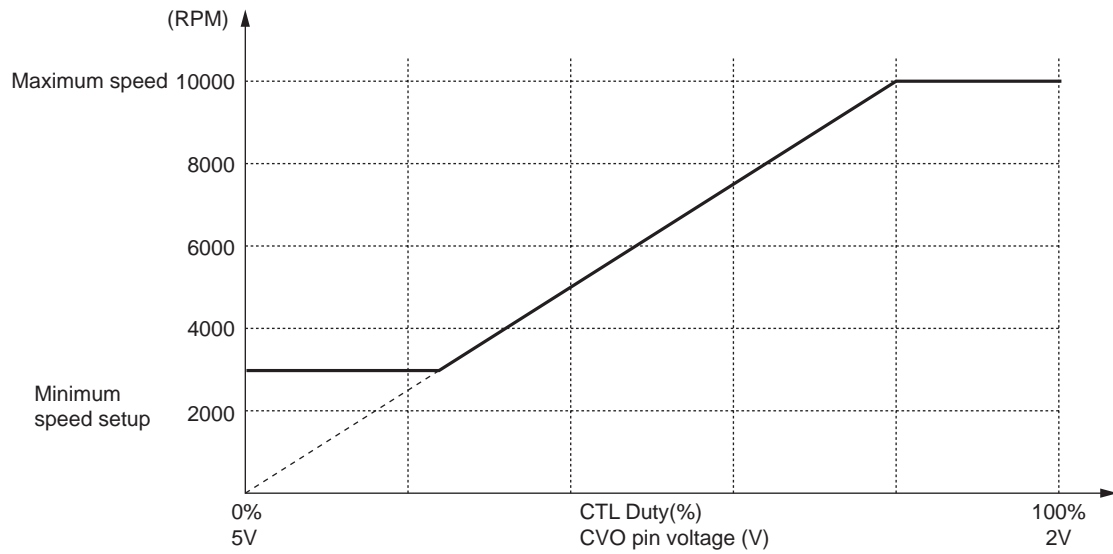

1) Obtain the ratio of the minimum speed required to the maximum speed.

$$Ra = \text{Minimum}/\text{maximum speed} \cdots (1)$$

In the example shown in the figure above : $Ra = \text{minimum}/\text{maximum speed} = 3000/10000 = 0.3$

2) Obtain the product of the duty ratio at which the maximum speed is achieved and the value in formula (1).

$$Ca = \text{Maximum speed duty ratio} \times Ra \cdots (2)$$

In the example given : $Ca = \text{maximum speed duty ratio} \times Ra = 0.8 \times 0.3 = 0.24$

3) Obtain the required LIM pin voltage.

$$LIM = 5 - (3 \times Ca) \cdots (3)$$

In the example given : $LIM = 5 - (3 \times Ca) = 5 - (3 \times 0.24) \approx 4.3V$

4) Divide the resistance of 5VREG to generate the LIM voltage.

In the example given, the voltage is 4.3V so the resistance ratio is 1 : 6.

The resistance is 10kΩ between 5VREG and LIM and 62kΩ between LIM and GND.

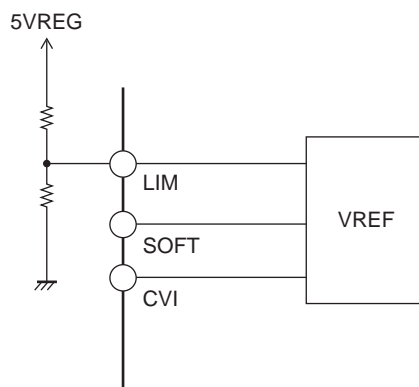

LB11852RV

⟨C pin⟩

In order to connect a capacitor capable of smoothing the pin voltage to the C pin, the correlation given in the following equation must be satisfied when f (Hz) serves as the input frequency of the CTL pin. (R is incorporated inside the IC, and it is $180\text{k}\Omega$ (typ.)

$$1/f = t < CR$$

The higher the capacitance of the capacitor, the slower the response to changes in the input signals.

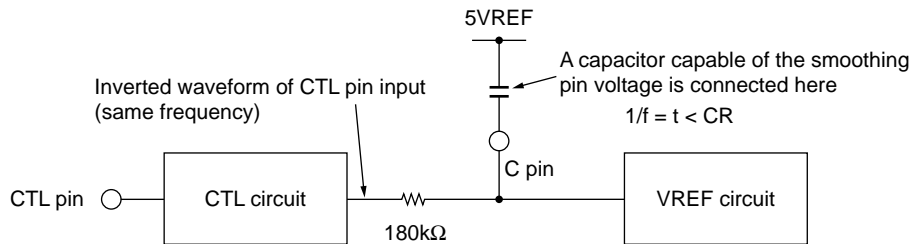

ON Semiconductor and the ON logo are registered trademarks of Semiconductor Components Industries, LLC (SCILLC). SCILLC owns the rights to a number of patents, trademarks, copyrights, trade secrets, and other intellectual property. A listing of SCILLC's product/patent coverage may be accessed at www.onsemi.com/site/pdf/Patent-Marking.pdf. SCILLC reserves the right to make changes without further notice to any products herein. SCILLC makes no warranty, representation or guarantee regarding the suitability of its products for any particular purpose, nor does SCILLC assume any liability arising out of the application or use of any product or circuit, and specifically disclaims any and all liability, including without limitation special, consequential or incidental damages. "Typical" parameters which may be provided in SCILLC data sheets and/or specifications can and do vary in different applications and actual performance may vary over time. All operating parameters, including "Typicals" must be validated for each customer application by customer's technical experts. SCILLC does not convey any license under its patent rights nor the rights of others. SCILLC products are not designed, intended, or authorized for use as components in systems intended for surgical implant into the body, or other applications intended to support or sustain life, or for any other application in which the failure of the SCILLC product could create a situation where personal injury or death may occur. Should Buyer purchase or use SCILLC products for any such unintended or unauthorized application, Buyer shall indemnify and hold SCILLC and its officers, employees, subsidiaries, affiliates, and distributors harmless against all claims, costs, damages, and expenses, and reasonable attorney fees arising out of, directly or indirectly, any claim of personal injury or death associated with such unintended or unauthorized use, even if such claim alleges that SCILLC was negligent regarding the design or manufacture of the part. SCILLC is an Equal Opportunity/Affirmative Action Employer. This literature is subject to all applicable copyright laws and is not for resale in any manner.