



ON Semiconductor®

<http://onsemi.com>

LB11851FA

Monolithic Digital IC

Microprocessor Fan Motor Interface Driver

Overview

The LB11851FA provides an interface between a microcontroller motor control signal and external MOS transistors. This device can implement a microprocessor fan driver with a minimal number of external components. The LB11851FA is optimal for server and personal computer microprocessor fan drive in response to temperature or other external signals when high precision and high air flow are required.

Features

- Fan motor interface driver function (FGIN)
 - ⇒ This IC accepts a signal from a microcontroller and interfaces to external power transistors (PMOS and NMOS) to provide high-efficiency low-power single-phase full-wave drive.
- Variable speed input pin (PWMIN)
 - ⇒ PMOS side PWM control
 - NMOS side current regeneration using slow decay is used to achieve quite high-speed control.
- Built-in kickback absorption circuit (OUT1P/2P)
 - ⇒ This circuit absorbs the kickback current that is generated at phase switching or power on/off to achieve smooth current regeneration and protect the external transistors against destruction or degradation.
- Built-in current limiter circuit (SENSE)
 - ⇒ This circuit implements a chopper-type current limiting control that operates at startup and during lock protection mode.
 - The current detection voltage is set to a fixed 0.2V internally.
- Built-in microcontroller power supply (5VREG)

LB11851FA

Specifications

Absolute Maximum Ratings at $T_a = 25^\circ\text{C}$

Parameter	Symbol	Conditions	Ratings	Unit
Maximum supply voltage	V_{CC} max		18	V
OUTN pin maximum output current	IOUTN max		20	mA
OUTP pin maximum output current	IOUTP max		20	mA
OUT pin voltage handling capacity	VOUT max		18	V
5VREG maximum output current	I5VREG max		20	mA
Allowable power dissipation	P_d max	When mounted on the specified circuit board *1	400	mW
Operating temperature	T_{opr}	*2	-40 to +90	$^\circ\text{C}$
Storage temperature	T_{stg}		-55 to +150	$^\circ\text{C}$

*1 Specified substrate :20.0mm ×10.0mm ×0.8mm, Paper phenol board.

*2 Do not exceed T_j max = 150°C

Caution 1) Absolute maximum ratings represent the value which cannot be exceeded for any length of time.

Caution 2) Even when the device is used within the range of absolute maximum ratings, as a result of continuous usage under high temperature, high current, high voltage, or drastic temperature change, the reliability of the IC may be degraded. Please contact us for the further details.

Stresses exceeding Maximum Ratings may damage the device. Maximum Ratings are stress ratings only. Functional operation above the Recommended Operating Conditions is not implied. Extended exposure to stresses above the Recommended Operating Conditions may affect device reliability.

Recommended Operating Ranges at $T_a = 25^\circ\text{C}$

Parameter	Symbol	Conditions	Ratings	Unit
Supply voltage - V_{CC}	V_{CC}		6 to 16	V
PWM high-level input voltage range	VPWMINH		2.1 to 5.0	V
PWM low-level input voltage range	VPWMINL		0 to 0.4	V
FGIN high-level input voltage range	VFGINH		2.1 to 5.0	V
FGIN low-level input voltage range	VFGINL		0 to 0.3	V
SENSE input voltage range	VSENop		0 to 5.0	V

Electrical Characteristics at $T_a = 25^\circ\text{C}$, $V_{DD} = 12\text{V}$

Parameter	Symbol	Conditions	Ratings			Unit
			min	typ	max	
Circuit current	I_{CC1}	With no load	3.5	5	6.5	mA
5VREG voltage	5VREG	5VREG = 10mA	4.8	5	5.2	V
SENSE pin detection voltage	VSENth		0.15	0.19	0.23	V
FGIN high-level input current	FGIhi	$V_{IN} = 3\text{V}$	60	80	100	μA
FGIN low-level input current	FGIlow	$V_{IN} = 0\text{V}$	-27	-21	-15	μA
PWMIN high-level current	PWMIhi	$V_{IN} = 3\text{V}$	35	45	55	μA
PWMIN low-level current	PWMIlow	$V_{IN} = 0\text{V}$	-27	-21	-14	μA
OUT1P, OUT2P high-level output voltage	V_{O12PH}	$I_O = 10\text{mA} *2$	10	11	11.9	V
		$I_O = 1\text{mA} *2$	11	11.3		V
OUT1P, OUT2P low-level output voltage	V_{O12PL}	$I_O = 10\text{mA} *2$	3	4	5	V
		$I_O = 1\text{mA} *2$		1.2	1.5	V
OUT1N, OUT2N high-level output voltage	V_{O12NH}	$I_O = 10\text{mA} *1$	9	10	11.9	V
		$I_O = 1\text{mA} *1$	10.8	11.1		V
OUT1N, OUT2N low-level output voltage	V_{O12NL}	$I_O = 10\text{mA} *1$	0.1	1	2	V
		$I_O = 1\text{mA} *1$		0.7	1	V

*1 : There is a built-in 100 Ω gate protection resistor.

*2 : There is a built-in 300 Ω gate protection resistor.

Truth Table

FGIN	PWMIN	SENSE	OUT1P	OUT1N	OUT2P	OUT2N	Mode
L	L	L	L	L	H	H	OUT1 → 2 drive
H			H	H	L	L	OUT2 → 1 drive
L	H	L	H	L	H	H	Regeneration mode (low side regeneration)
H			H	H	L	L	
L	L	H	H	L	H	H	Current limiter (low side regeneration)
H			H	H	H	L	

Note 1 : For the SENSE pin, the "H" state is 0.2V or higher.

Note 2 : The IC goes to regeneration mode (no motor drive applied) when the microcontroller is reset (the output high-impedance state).

LB11851FA

Package Dimensions

unit : mm (typ)
3428

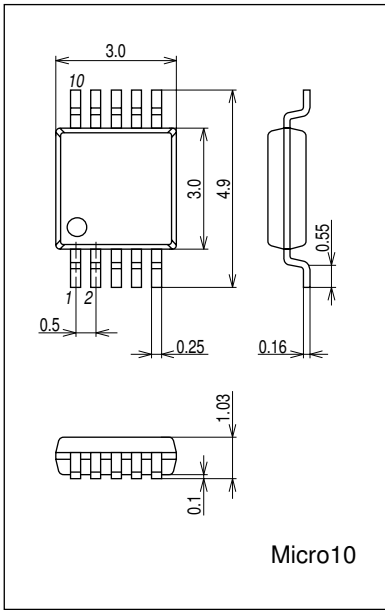

Pin Assignment

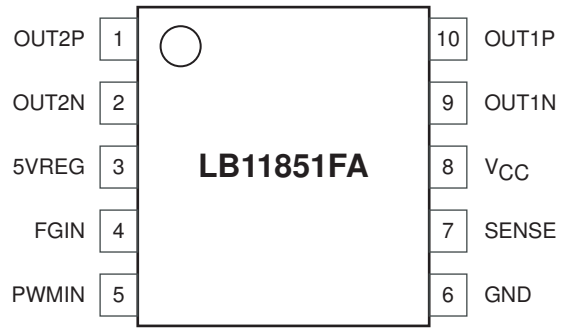

Top View

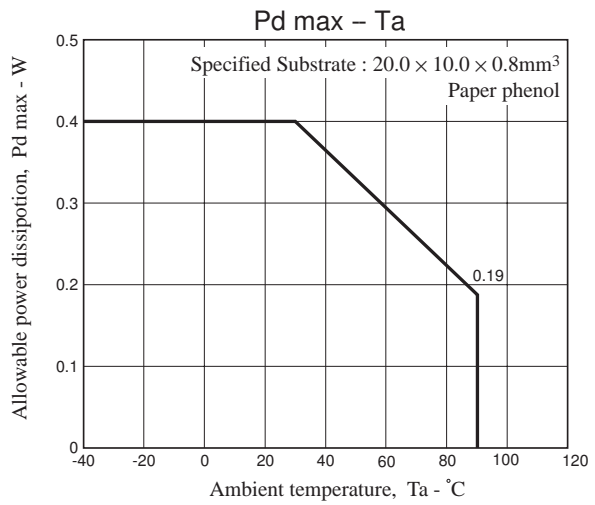

Block Diagram

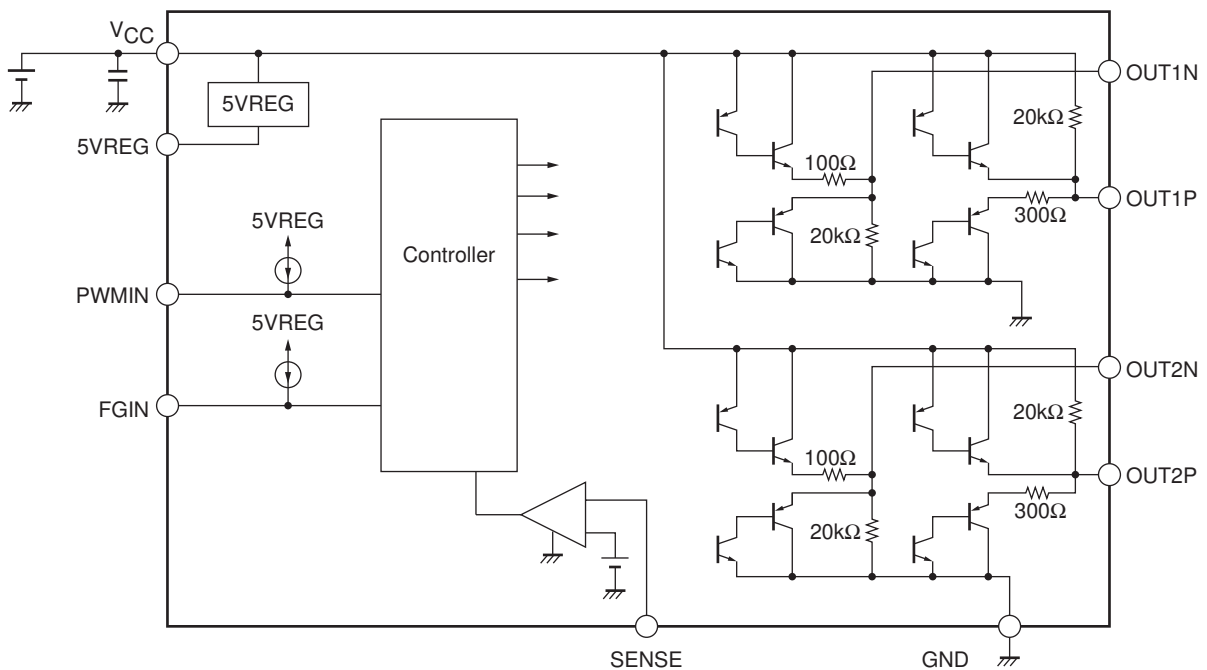

LB11851FA

1. Power supply (V_{CC} and V_M) and ground

The wiring is separated into the control IC side (V_{CC} line) and the motor output side (V_M line) by the diode DI, which protects the IC from destruction on reverse connection. The application circuit uses $1\mu\text{F}$ capacitors to prevent line oscillation when kickback occurs. Similarly, $1\mu\text{F}$ capacitors are also used on the V_{CC} line for power supply line stabilization.

2. PWMIN

The LB11851M accepts an open-drain output signal from the microcontroller with this pin and controls the on/off states of the PMOS transistor (OUT1P and OUT2P) outputs accordingly. A constant-current bias is provided from 5VREG internally to the IC.

3. FGIN

The LB11851M accepts a CMOS output from the microcontroller with this pin and determines the drive phase output (OUT1P, OUT2P, OUT1N, or OUT2N).

4. 5VREG

This is the power supply for the microcontroller, Hall effect sensors, and other circuits. A capacitor with a value of $1\mu\text{F}$ is used for output stabilization. This pin has an output current capacity of 20mA.

5. SENSE

A sensing resistor is used for current detection. If the SENSE pin voltage exceeds 0.2V, the PMOS transistors are turned off and only low side regeneration is performed.

*<OUT1, 2P output H voltage / OUT1, 2N output L voltage>

Output L voltage of OUT1 and 2 sticks in GND when FET is put up outside like the example of applied circuit by internal pull-down resistor ($20\text{k}\Omega$), and there is no what turns on FET.

Output H voltage of OUT1 and 2 sticks in VCC with internal pull-up resistor ($20\text{k}\Omega$) as the Pch side is also similar.

ON Semiconductor and the ON logo are registered trademarks of Semiconductor Components Industries, LLC (SCILLC). SCILLC owns the rights to a number of patents, trademarks, copyrights, trade secrets, and other intellectual property. A listing of SCILLC's product/patent coverage may be accessed at www.onsemi.com/site/pdf/Patent-Marking.pdf. SCILLC reserves the right to make changes without further notice to any products herein. SCILLC makes no warranty, representation or guarantee regarding the suitability of its products for any particular purpose, nor does SCILLC assume any liability arising out of the application or use of any product or circuit, and specifically disclaims any and all liability, including without limitation special, consequential or incidental damages. "Typical" parameters which may be provided in SCILLC data sheets and/or specifications can and do vary in different applications and actual performance may vary over time. All operating parameters, including "Typicals" must be validated for each customer application by customer's technical experts. SCILLC does not convey any license under its patent rights nor the rights of others. SCILLC products are not designed, intended, or authorized for use as components in systems intended for surgical implant into the body, or other applications intended to support or sustain life, or for any other application in which the failure of the SCILLC product could create a situation where personal injury or death may occur. Should Buyer purchase or use SCILLC products for any such unintended or unauthorized application, Buyer shall indemnify and hold SCILLC and its officers, employees, subsidiaries, affiliates, and distributors harmless against all claims, costs, damages, and expenses, and reasonable attorney fees arising out of, directly or indirectly, any claim of personal injury or death associated with such unintended or unauthorized use, even if such claim alleges that SCILLC was negligent regarding the design or manufacture of the part. SCILLC is an Equal Opportunity/Affirmative Action Employer. This literature is subject to all applicable copyright laws and is not for resale in any manner.