



ON Semiconductor®

<http://onsemi.com>

LB11660RV

Monolithic Digital IC Single-Phase Full-Wave Driver For Fan Motor

Overview

The LB11660RV is a single-phase bipolar half pre-driver that can achieve high-efficient direct PWM drive with ease. It is ideal for driving small-sized cooling fans used in servers. The LB11660RV is provided with the RD (lock detection) output pin and the LB11660FV the FG (rotational speed detection) output pin, respectively.

Features

- Single-phase full-wave drive (15V-1.5A output transistor built in) upper output Tr incorporated half pre-driver.
- Variable speed control by an external signal.
→Separately-excited upper TR direct PWM control method, enabling silent, low-vibration variable speed control.
- Lowest speed setting possible.
- Current limiter circuit (the circuit actuated at $I_O = 1A$ when $R_f = 0.5\Omega$, R_f determines the limiter value.).
- Kickback absorption circuit built in.
- Soft switching circuit achieves low power consumption, low loss, and low noise driving at a time of phase change.
- HB built in.
- Lock protection and automatic reset functions incorporated (including a circuit that changes the ON/OFF ratio according to the power supply voltage).
- RD (lock detection) output.
- Thermal protection circuit incorporated (design guaranteed).

LB11660RV

Absolute Maximum Ratings at $T_a = 25^\circ\text{C}$

Parameter	Symbol	Conditions	Ratings	Unit
V_{CC} maximum power supply voltage	V_{CC} max		20	V
VM maximum power supply voltage	VM max		20	V
OUT pin maximum output current	I_{OUT} max	$R_f \geq 0.39\Omega$	1.5	A
OUT pin output withstand voltage 1	V_{OUT} max1		20	V
OUT pin output withstand voltage 2	V_{OUT} max2	$T \leq 0.4\mu\text{s}$	26.5	V
PRE pin maximum source current	IPSO max		30	mA
PRE pin maximum sink current	IPSI max		-7	mA
PRE pin output withstand voltage	VP max		20	V
HB maximum output current	HB		10	mA
VTH input pin withstand voltage	VTH max		7	V
RD output pin output withstand voltage	VRD max		18	V
RD output current	IRD max		10	mA
Allowable power dissipation	P_d max	Mounted on a specified board *1	0.8	W
Operating temperature range	Topr	*2	-30 to 95	$^\circ\text{C}$
Storage temperature range	Tstg		-55 to 150	$^\circ\text{C}$

*1 A circuit board for mounting (114.3mm×76.1mm×1.6mm, glass epoxy resin)

*2 T_j max = 150°C . Must be used within the operating temperature range in which T_j does not exceed 150°C .

Stresses exceeding Maximum Ratings may damage the device. Maximum Ratings are stress ratings only. Functional operation above the Recommended Operating Conditions is not implied. Extended exposure to stresses above the Recommended Operating Conditions may affect device reliability.

Recommended Operating Range at $T_a = 25^\circ\text{C}$

Parameter	Symbol	Conditions	Ratings	Unit
V_{CC} power supply voltage	V_{CC}		4 to 15	V
VM power supply voltage	V_{CC}		3 to 15	V
Current limiter operating range	ILIM		0.6 to 1.2	A
VTH input level voltage range	VTH		0 to 6	V
Hall input common phase input voltage range	VICM		0.2 to 3	V

Electrical Characteristics at $T_a = 25^\circ\text{C}$, $V_{CC} = 12\text{V}$, unless otherwise specified

Parameter	Symbol	Conditions	Ratings			Unit
			min	typ	max	
Circuit current	I_{CC1}	During driving		9	12	mA
HB voltage	VHB	IHB=5mA	1.05	1.25	1.40	V
6VREG voltage	V6VREG	6VREG=5mA	5.80	6	6.20	V
CT pin H level voltage	VCTH		3.4	3.6	3.8	V
CT pin L level voltage	VCTL		1.4	1.6	1.8	V
ICT pin charge current 1	ICTC1	$V_{CC}=12\text{V}$	1.7	2.2	2.7	μA
ICT pin charge current 2	ICTC2	$V_{CC}=6\text{V}$	1.3	1.8	2.3	μA
ICT pin discharge current 1	ICTD1	$V_{CC}=12\text{V}$	0.11	0.15	0.19	μA
ICT pin discharge current 2	ICTD2	$V_{CC}=6\text{V}$	0.34	0.44	0.54	μA
ICT charge/discharge ratio 1	RCT1	$V_{CC}=12\text{V}$	12	15	18	
ICT charge/discharge ratio 2	RCT2	$V_{CC}=6\text{V}$	3	4	5	
ICT charge/discharge ratio threshold voltage	VRCT		6	6.6	7.3	V
VTH bias current	IBVTH		-2	-1	0	μA
OUT output H saturation voltage	VOH	$I_O=200\text{mA}$, $R_L=1\Omega$		0.6	0.8	V
PRE output L saturation voltage	VPL	$I_O=5\text{mA}$		0.2	0.4	V
PRE output H saturation voltage	VPH	$I_O= -20\text{mA}$		0.9	1.2	V

Continued on next page.

LB11660RV

Continued from preceding page.

Parameter	Symbol	Conditions	Ratings			Unit
			min	typ	max	
Current limiter	VRf	V _{CC} -VM	450	500	550	mV
PWM output H level voltage	VPWMH		2.2	2.5	2.8	V
PWM output L level voltage	VPWML		0.4	0.5	0.7	V
PWM external C capacitor charge current	IPWM1		-23	-18	-14	μA
PWM external C capacitor discharge current	IPWM2		18	24	30	μA
PWM oscillation frequency	FPWM	C=200pF	19	23	27	kHz
Hall input sensitivity	VHN	Zero peak value (including offset and hysteresis)		15	25	mV
RD output pin L voltage	VRD	IRD=5mA		0.2	0.3	V
RD output pin leak current	IRD_L	VRD=7V			30	μA
Thermal protection circuit	THD	Design target value *3	150	180	210	°C

*3 These are design guarantee values, and are not tested.

The thermal protection circuit is implemented to prevent the IC from being thermally damaged or burned when exposed to an environment exceeding the guaranteed operating temperature range. Thermal design must be carried out so that the thermal protection circuit will never be activated while the fan is running in a stable condition.

Package Dimensions

unit : mm (typ)

3178B

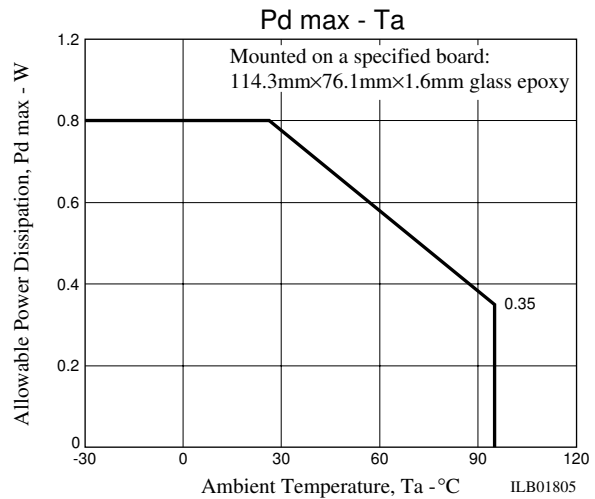
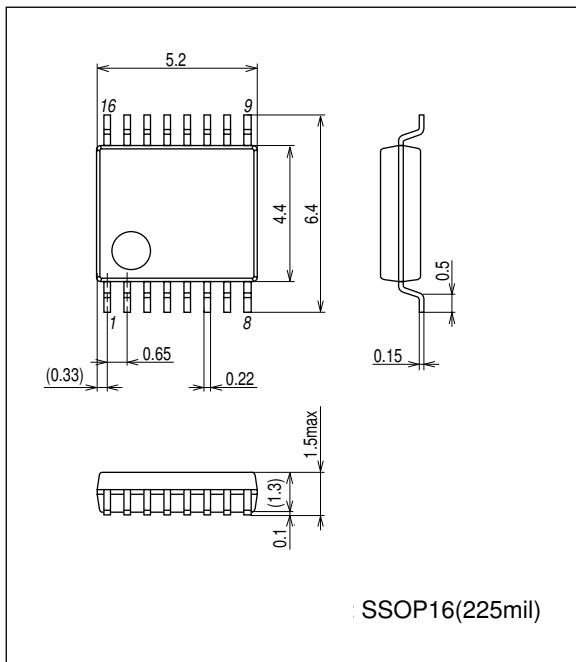

Truth Table

IN-	IN+	VTH	CPWM	CT	OUT1	OUT2	PRE1	PRE2	RD	Mode
H	L	L	H	L	H	OFF	L	H	L	Rotating - drive
L	H				OFF	H	H	L		
H	L	H	L		OFF	OFF	L	H		Rotating - regeneration
L	H				OFF	OFF	H	L		
H	L	-	-	H	OFF	OFF	L	H	OFF	Lock protection
L	H				OFF	OFF	H	L		

CPWM-H: CPWM>VTH, CPWM-L: CPWM<VTH

LB11660RV

Pin Assignment

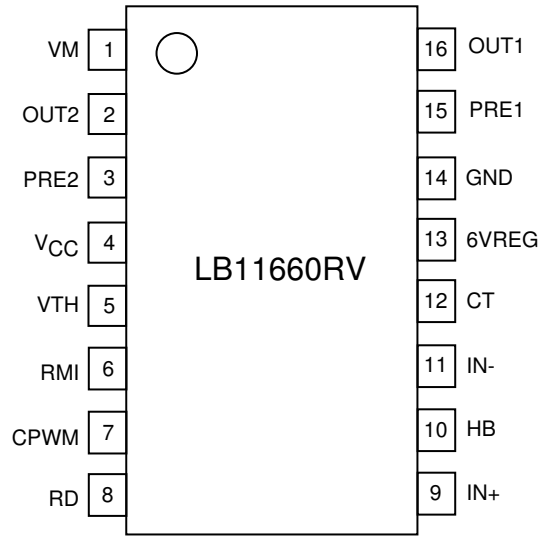

Top view

Sample Application Circuit 1

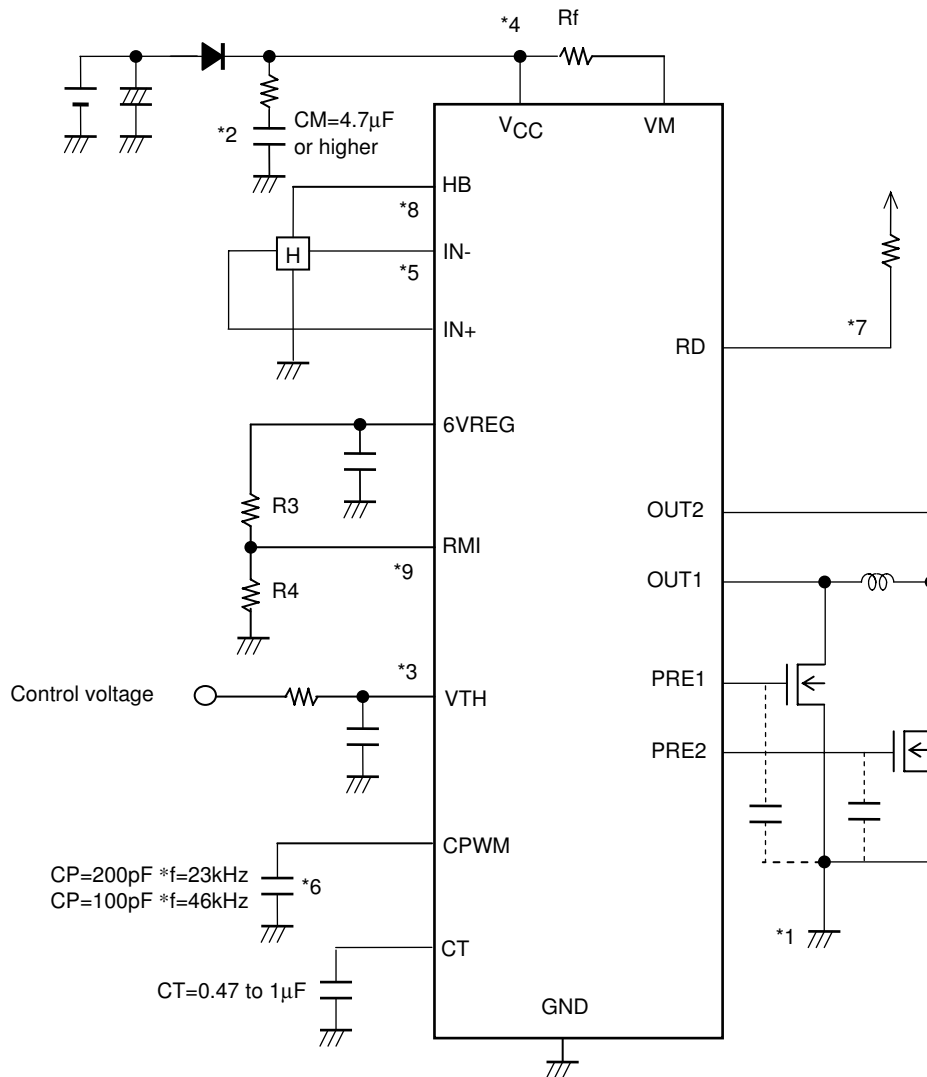

*1 <Power supply - GND wiring>

GRD of the IC is connected to the control circuit power supply system and GRD of the external N-channel is connected to the motor power supply system. Groundings must be installed separately and all external control components must be connected to the GND line of the IC.

*2 <Power stabilization capacitor for regeneration>

For the CM capacitor, that is a power stabilization capacitor for PWM drive and for absorption of kick-back, a capacitance of 4.7 μ F/25V or higher must be used. The CM capacitor must be connected without fail to prevent the IC from being damaged when power is tuned on or off.

*3 <Speed control>

1) Control voltage

The PWM duty ratio is determined by comparing the VTH pin voltage and the PWM oscillation waveforms.

When the VTH pin voltage drops, the 'ON' duty ratio increases, and when it drops to or below the PWM output L level voltage, the duty ratio is 100%.

2) Thermistor

In thermistor applications, the 6VREG voltage is usually divided by a resistor, and the voltage thus generated is supplied to the VTH pin.

The PWM duty ratio is varied by the changes in the VTH pin voltage which result from changes in temperature.

*4 < Setting the current limiter >

The current limiter is actuated when the voltage of the current-sensing resistors between V_{CC} and VM increases to 0.5V or more.

Since the current of a current limiter circuit is limited by the current determined by $I_O = VR_f/R_f$ (where $VR_f = 0.5V$ typ, R_f : current-sensing resistance), the current limiter is actuated at $I_O = 1A$ when $R_f = 0.5\Omega$. The R_f resistor must be connected without fail, and its constant must be within the recommended operating range for current limiters.

*5 <Hall input>

Wiring need to be short to prevent carrying of the noise. The Hall input circuit is a comparator having a hysteresis of 20mV. It is recommended that the Hall input level be more than three times (60mV_{p-p}) this hysteresis.

*6 < PWM oscillation frequency setting capacitor >

The oscillation frequency is 23kHz when $CP = 200pF$ and 46kHz when $CP = 100pF$, and this serves as the PWM fundamental frequency.

For the most part, the PWM frequency can be obtained from the following formula:

$$f [\text{kHz}] \approx (4.6 \times 10^6) \div C [\text{pF}]$$

*7 <RD output>

This is the open collector type output, which outputs "L" during rotation. It is set to 'OFF' when a lock is detected.

This output is left open when not in use.

*8 <HB pin>

This is a Hall element bias pin, that is, the 1.25V constant-voltage output pin.

*9 <RMI pin>

Lowest speed setting pin for speed control.

The minimum output duty setting is made with R3 and R4. The R4 is left open to stop operation at a duty ratio of 0%.

Rotation Speed Control Chart

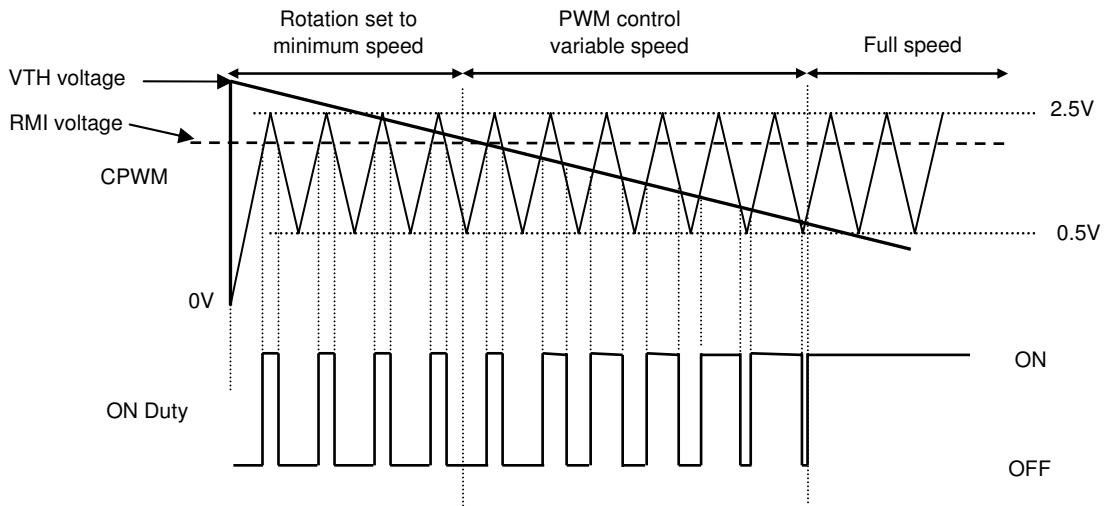
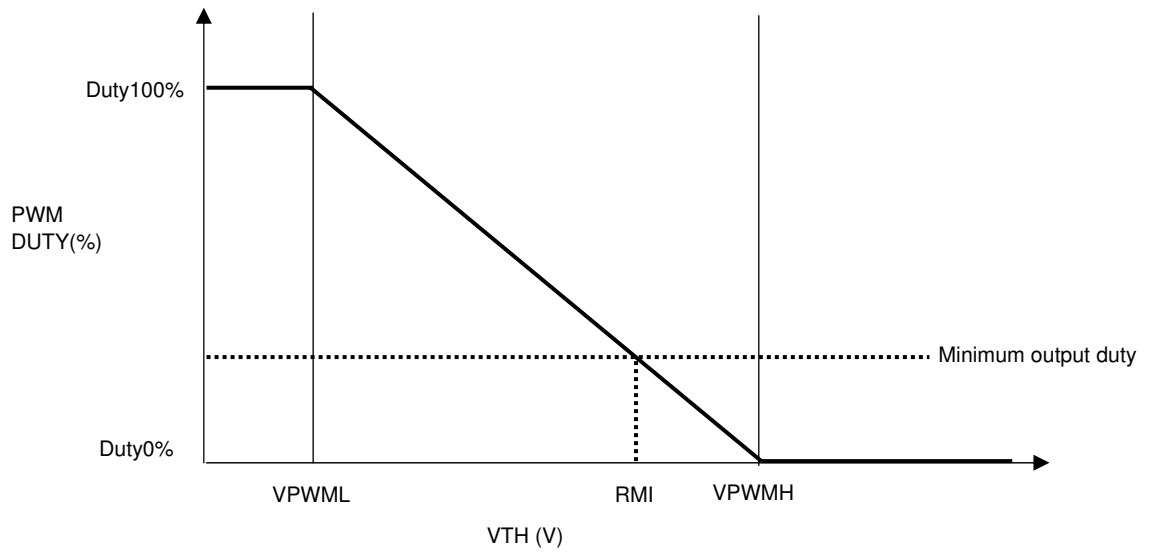

Internal Equivalent Circuit Diagram

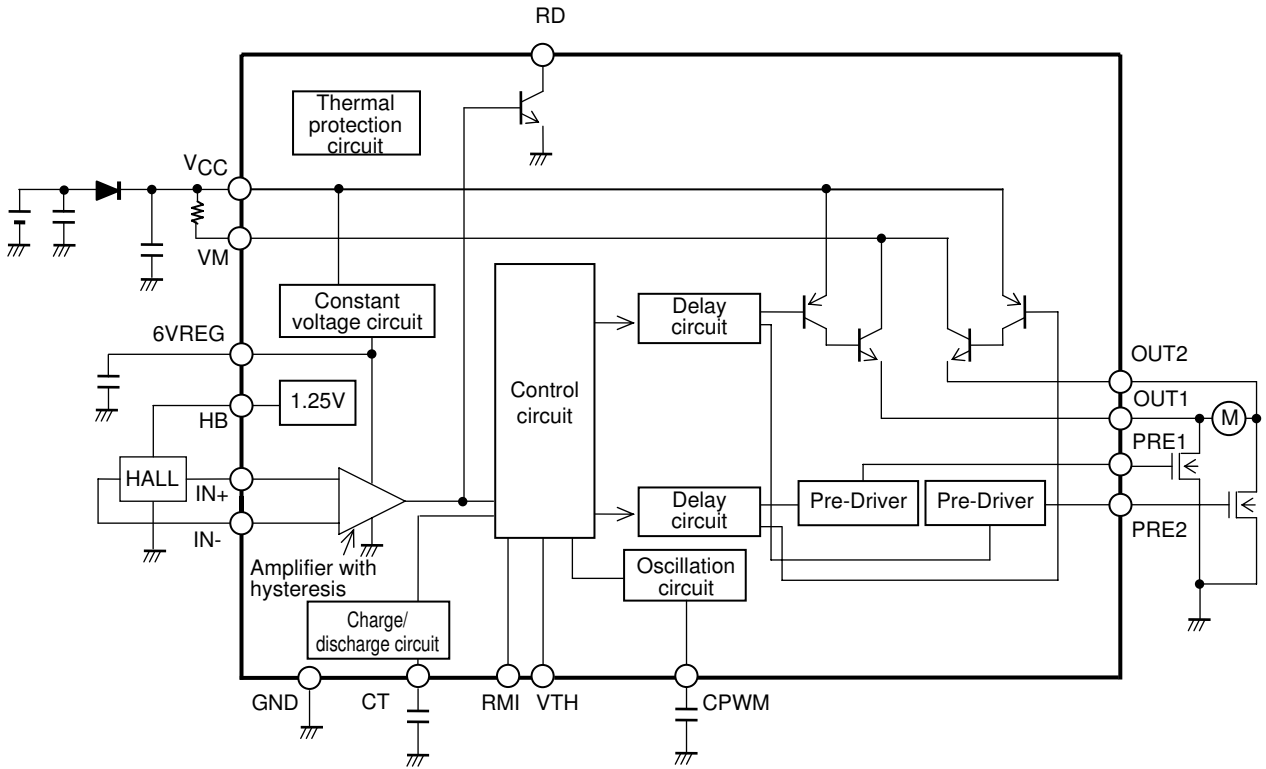

LB11660RV

Sample Application Circuit 2 <no minimum speed setting, thermistor input>

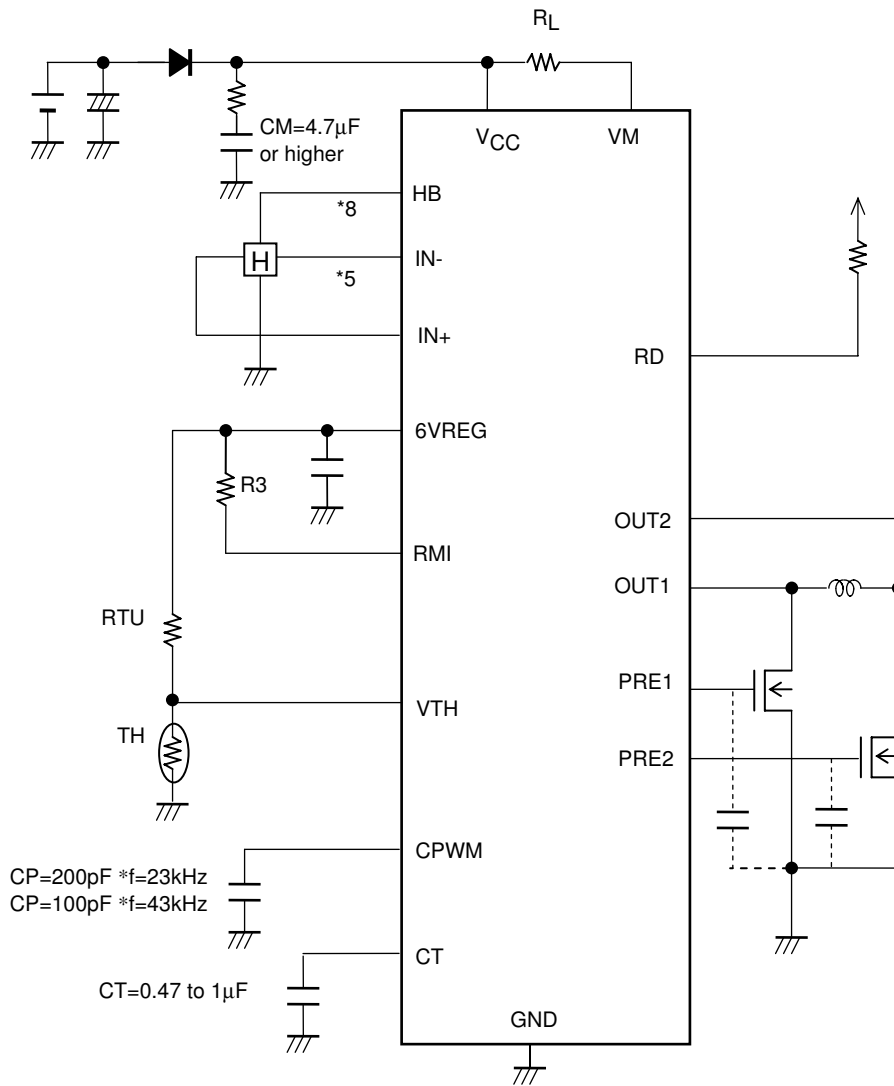

ON Semiconductor and the ON logo are registered trademarks of Semiconductor Components Industries, LLC (SCILLC). SCILLC owns the rights to a number of patents, trademarks, copyrights, trade secrets, and other intellectual property. A listing of SCILLC's product/patent coverage may be accessed at www.onsemi.com/site/pdf/Patent-Marking.pdf. SCILLC reserves the right to make changes without further notice to any products herein. SCILLC makes no warranty, representation or guarantee regarding the suitability of its products for any particular purpose, nor does SCILLC assume any liability arising out of the application or use of any product or circuit, and specifically disclaims any and all liability, including without limitation special, consequential or incidental damages. "Typical" parameters which may be provided in SCILLC data sheets and/or specifications can and do vary in different applications and actual performance may vary over time. All operating parameters, including "Typicals" must be validated for each customer application by customer's technical experts. SCILLC does not convey any license under its patent rights nor the rights of others. SCILLC products are not designed, intended, or authorized for use as components in systems intended for surgical implant into the body, or other applications intended to support or sustain life, or for any other application in which the failure of the SCILLC product could create a situation where personal injury or death may occur. Should Buyer purchase or use SCILLC products for any such unintended or unauthorized application, Buyer shall indemnify and hold SCILLC and its officers, employees, subsidiaries, affiliates, and distributors harmless against all claims, costs, damages, and expenses, and reasonable attorney fees arising out of, directly or indirectly, any claim of personal injury or death associated with such unintended or unauthorized use, even if such claim alleges that SCILLC was negligent regarding the design or manufacture of the part. SCILLC is an Equal Opportunity/Affirmative Action Employer. This literature is subject to all applicable copyright laws and is not for resale in any manner.