



ON Semiconductor®

<http://onsemi.com>

LV8163QA

Bi-CMOS IC

Fan Motor Driver

Single-Phase Full-Wave Driver

Overview

The LV8163QA is a driver IC for single phase fan motor which operates noiselessly by BTL linear output method. The LV8163QA has variable speed function that corresponds to external PWM single input. Therefore, this IC is suitable for CPU cooler for note PC and the like which requires low power consumption, noiseless operation and variable speed functions.

Functions

- Single phase full wave drive by BTL output method.
- Speed control function by PWM input.
- Integrated lock protector and auto recovery circuit.
- Standby mode and quick start function.
- Hall bias output pin.
- Startup support function (100% DUTYSTART)
- FG signal pin, RD signal pin
- Integrated TSD (Thermal ShutDown) circuit

Specifications

Absolute Maximum Ratings at Ta = 25°C

Parameter	Symbol	Conditions	Ratings	Unit
Power supply voltage	V _{CC} max		7	V
Output pin current	I _{OUT} max		0.7	A
Output pin withstand voltage	V _{OUT} max		7	V
HB output current	I _{HB} max		10	mA
PWM pin voltage	V _{PWM} max		7	V
FG/RD pin sink current	I _{FG/IRD} max		5	mA
FG/RD output pin voltage	V _{FG/VRD} max		7	V
Allowable power dissipation	P _d max	Mounted on specified board *1	1050	mW
Operating temperature	T _{opr}		-30 to +95	°C
Storage temperature	T _{stg}		-55 to +150	°C

*1 Specified substrate : 105mm × 120mm × 1.6mm, two-sided glass epoxy board

*2 Do not exceed T_{jmax} = 150°C

Caution 1) Absolute maximum ratings represent the value which cannot be exceeded for any length of time.

Caution 2) Even when the device is used within the range of absolute maximum ratings, as a result of continuous usage under high temperature, high current, high voltage, or drastic temperature change, the reliability of the IC may be degraded. Please contact us for the further details.

Stresses exceeding Maximum Ratings may damage the device. Maximum Ratings are stress ratings only. Functional operation above the Recommended Operating Conditions is not implied. Extended exposure to stresses above the Recommended Operating Conditions may affect device reliability.

LV8163QA

Operating Conditions at Ta = 25°C

Parameter	Symbol	Conditions	Ratings	Unit
Power supply voltage	VCC		5.0	V
Operating power supply voltage	VCCop		2.0 to 6.0	V
Hall input common-mode input voltage range	VICM		0.2 to VCC-1.2	V
PWM pin input frequency	FPWMIN		20 to 60	kHz

Electrical Characteristics at Ta = 25°C, VCC = 5V

Parameter	Symbol	Conditions	Ratings			Unit
			min	typ	max	
Circuit current	ICC	During operation	0.95	1.3	1.6	mA
	ICC st	During Standby mode		10	30	μA
HB pin voltage	VHB	IHB = 5mA	0.9	1.03	1.2	V
Output pin high-level voltage	VOH	IOUT = 200mA (VCC - VOUT)		0.16	0.23	V
Output pin low-level voltage	VOL	IOUT = 200mA		0.10	0.15	V
Hall amplifier input offset voltage	VINOFFS		-6		6	mV
Hall amplifier voltage gain	GH		44	45.5	47	dB
PWM pin input Low level voltage	VPWML		0		VCC×0.2	V
PWM pin input High level voltage	VPWMH	VCC < 4V	1.8		6.0	V
		4V ≤ VCC	VCC×0.45		6.0	V
FG/RD pin low-level voltage	VFGL/VRDL	IFG/IRD = 3mA			0.3	V
FG/RD pin leak current	IFGL/IRDL	VFG/VRD = 7V			10	μA
FG comparator hysteresis width	FGHYS			±8	±16	mV
Lock-detection output ON time	LT1		0.4	0.6	0.8	sec
Lock-detection output OFF time	LT2		4	6	8	sec
Lock-detection output ON/OFF ratio	LRTO	LRTO=LT2/LT1	8	10	12	
Thermal shutdown operating temperature	TSD	Design guarantee *		180		°C
Thermal shutdown hysteresis width	ΔTSD	Design guarantee *		30		°C

* Design target: These values are the target value in designs. The parameters are not measured independently.

Pin Assignment

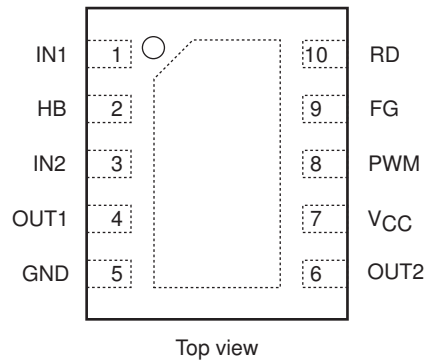

Truth value table

IN1	IN2	PWM	OUT1	OUT2	FG	RD	Mode
High	Low	High	Low	High	OFF	Low	Operation (OUT2→OUT1)
		Low		Low		Recirculation	
		*		OFF		Lock protector (see *1)	
Low	High	High	High	Low	Low	Low	Operation (OUT1→OUT2)
		Low	Low			Low	Recirculation
		*	OFF			OFF	Lock protector (see *1)
*		Low	Low	Low	OFF	Low	Standby (see *2)

*1 If FG pulse is not switched when lock detection output is ON, lock protector mode is set.

*2 Standby mode is set when time of lock protector + PWM input low level voltage is greater than 750μs.

Standby mode is set when time of low level voltage is 750μs and voltage is supplied and PWM input is at low level voltage.

LV8163QA

Package Dimensions

unit : mm (typ)

3432

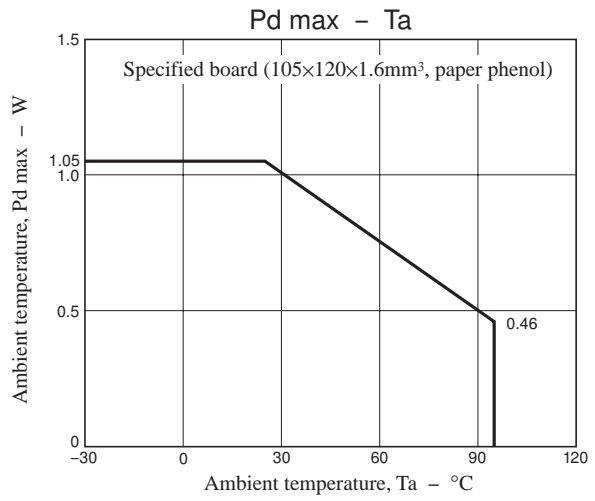
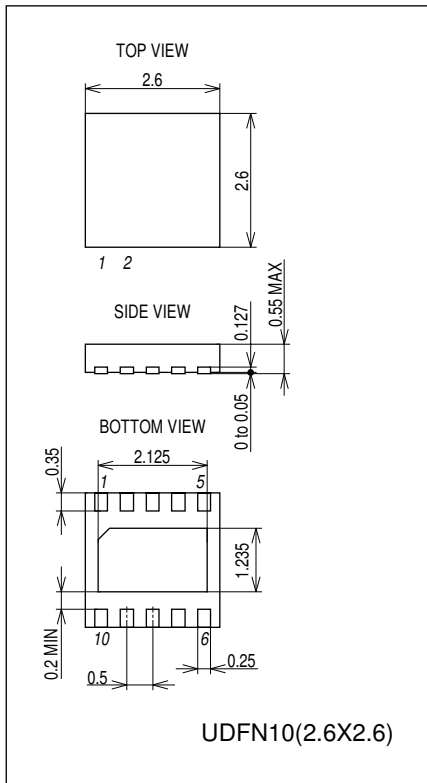

Block Diagram

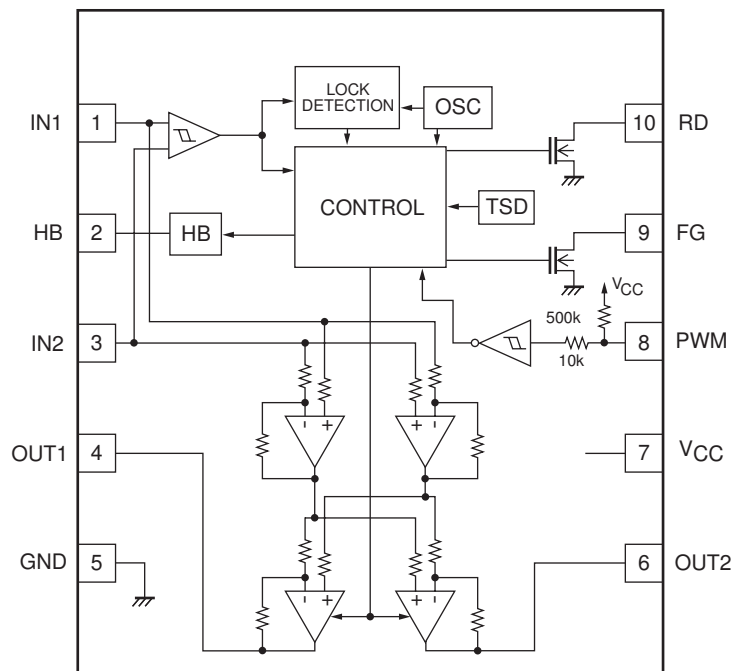

Example of circuit application

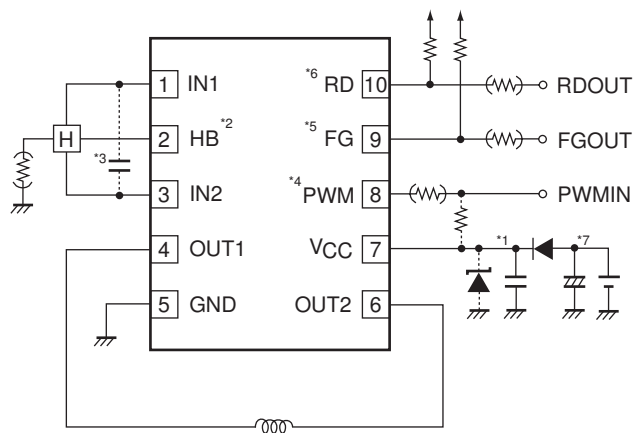

*1 < Capacitor for power stabilization >

The capacitor for power stabilization must be 1 μ F or greater. The capacitor is not removable. Make sure to connect the capacitor with the thickest and shortest possible pattern between VCC and GND. When a protection diode against reverse connection is used. If supply voltage increases due to coil kickback, connect zener diode between power supply and GND.

This IC performs synchronous rectification to reduce heat generation and to enhance efficiency. Depends on usage conditions, coil current may flow back to power supply by synchronous rectification.

*when output DUTY is reduced rapidly.

*When PWM input frequency is low.

The increase of supply voltage varies depends on the presence of diode (to prevent IC destruction from reverse connection), the size of power capacitor, and usage fan. If the increase of supply voltage is excessive, use capacitor with enough capacitance or connect zener between power supply and GND so that the voltage is within the absolute maximum ratings.

*2 < HB pin >

Constant voltage output pin, which is used as bias for Hall element.

When Hall element is biased from VCC line and HB pin is unused, HB pin should be pulled down to GND with resistor of 1k Ω .

Bias for power supply and bias for HB pin cannot be used together.

Connect a resistor between Hall element and GND to adjust amplitude of Hall element.

*3 < IN1,IN2 pin >

Hall element signal input pin.

Make sure to keep the wiring short to prevent noise.

If noise is generated, use capacitor between IN1 and IN2.

As for Hall input level, the following conditions must be met:

Difference of voltage between IN1 and IN2 > usage voltage / Hall amplifier gain + Hall amplifier input offset

*4 < PWM pin >

Motor speed control signal input pin.

PWM pin is pulled up at 500k Ω in LV8136QA.

Resistance of 500k Ω is used for full-speed setting when PWM pin is open.

In order to control motor speed using open Collector input method (open drain), pull-up is required using suitable resistance.

Pull-up resistance is not required when motor speed is controlled by Push-pull input method.

The order of power supply is optional; either to power supply voltage or PWM input, under one of the following conditions.

1) When open collector input method is used.

2) Pull-up resistance is not implemented and Push-pull input method is used.

It is recommended to connect a resistance greater than 1k Ω in series to protect PWM pin against open GND and misconnection.

*5 < FG pin >

Used as rotation counter.

This pin is open drain output. You can count rotations according to phase change.

This pin is set to off during standby mode.

Make sure to set this pin open when unused.

It is recommended to connect a resistance greater than 1k Ω in series to protect PWM pin against open GND and misconnection.

*6 < RD pin >

Used as lock detector.

This pin is open drain output. During rotation, RD pin is set to low-level voltage. During lock detection, it is set to off.

During standby, it is set to low-level voltage.

Make sure to set this pin open when unused.

It is recommended to connect a resistance greater than 1k Ω in series to protect PWM pin against open GND and misconnection.

*7 < Low power dissipation during standby >

During standby, the fan motor used in LV8136QA can reduce power dissipation into 10 μ A (under room temperature, Typ).

However, power dissipation cannot be reduced into 10 μ A under the following conditions.

- When bias of Hall element is supplied from power supply:

- Current flowing into Hall element increases.

- When pull-up resistor is used to PWM pin

- During standby, the current flowing into pull-up resistor increases because PWM pin must be set to low-level voltage.

- When using RD pin

- During standby, the current flowing into pull-up resistor increases because RD pin turns low-level voltage.

Timing Chart

Switch: stand-by/operation

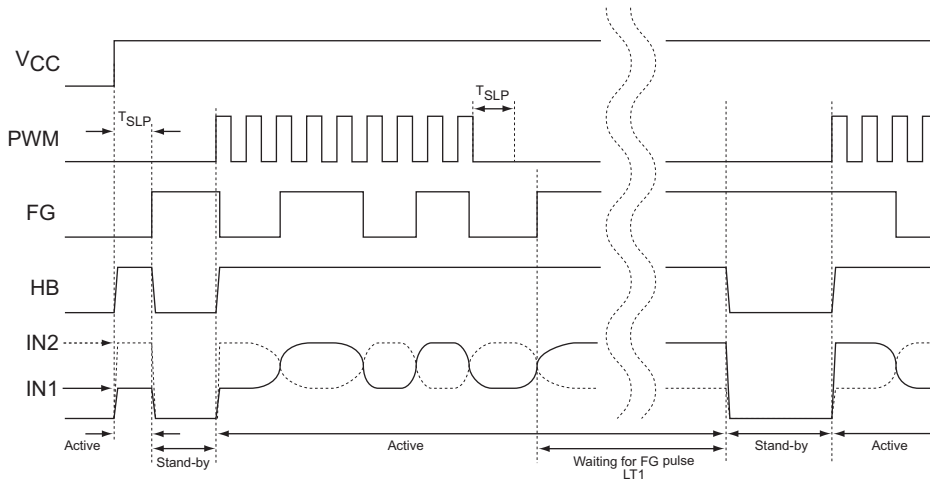

- *1 $T_{SLP}=750\mu s$ (typ)
- *2 If PWM signal is low-level voltage for the period of T_{SLP} and FG signal is not switched for the period of $LT1$, the mode is set to standby.
When turning on power, if PWM signal is low-level voltage for the period of T_{SLP} , the mode is set to standby.
- *3 During standby mode, FG pin is set to OFF and RD pin is set to low-level voltage.

Lock protector

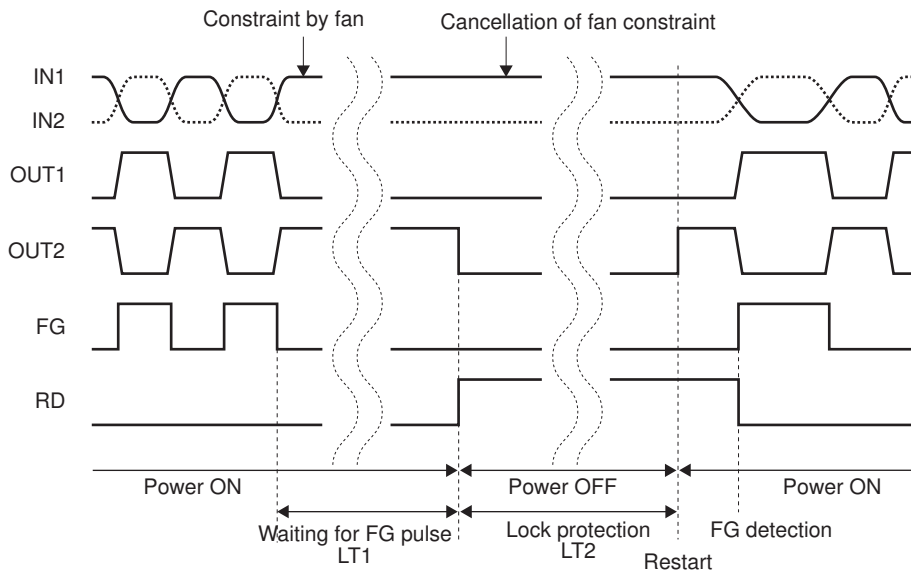

- *1 When lock protector is in operation, OUT1 and OUT2 are both set to low-level voltage.
- *2 RD is set to off during the period of lock protection. After lock protector is cancelled, RD is set to low-level voltage when FG switches from OFF to L or L OFF.
- *3 If PWM = low-level voltage is inputted for the period of T_{SLP} during lock protection, the mode is set to standby.
- *4 The operations start at 100% DUTY when turning on the power, cancelling lock protection, or recovering from standby mode.
(Switch of FG between OFF → L and L → OFF takes place for 5 or 6 times)

ON Semiconductor and the ON logo are registered trademarks of Semiconductor Components Industries, LLC (SCILLC). SCILLC owns the rights to a number of patents, trademarks, copyrights, trade secrets, and other intellectual property. A listing of SCILLC's product/patent coverage may be accessed at www.onsemi.com/site/pdf/Patent-Marking.pdf. SCILLC reserves the right to make changes without further notice to any products herein. SCILLC makes no warranty, representation or guarantee regarding the suitability of its products for any particular purpose, nor does SCILLC assume any liability arising out of the application or use of any product or circuit, and specifically disclaims any and all liability, including without limitation special, consequential or incidental damages. "Typical" parameters which may be provided in SCILLC data sheets and/or specifications can and do vary in different applications and actual performance may vary over time. All operating parameters, including "Typicals" must be validated for each customer application by customer's technical experts. SCILLC does not convey any license under its patent rights nor the rights of others. SCILLC products are not designed, intended, or authorized for use as components in systems intended for surgical implant into the body, or other applications intended to support or sustain life, or for any other application in which the failure of the SCILLC product could create a situation where personal injury or death may occur. Should Buyer purchase or use SCILLC products for any such unintended or unauthorized application, Buyer shall indemnify and hold SCILLC and its officers, employees, subsidiaries, affiliates, and distributors harmless against all claims, costs, damages, and expenses, and reasonable attorney fees arising out of, directly or indirectly, any claim of personal injury or death associated with such unintended or unauthorized use, even if such claim alleges that SCILLC was negligent regarding the design or manufacture of the part. SCILLC is an Equal Opportunity/Affirmative Action Employer. This literature is subject to all applicable copyright laws and is not for resale in any manner.