



ON Semiconductor®

<http://onsemi.com>

LV8063FA

Bi-CMOS IC Fan Motor Driver Single-Phase Full-Wave Driver

Overview

The LV8063FA is the driver IC with BTL linear output for single-phase fan motor, and that drives at high efficiency, low power, and low noise by suppressing the reactive power.

The BTL output can be combined with the PWM control by an external signal, which is optimum for the note PC, the CPU cooler, etc. that requires low power dissipation and low noise.

Functions

- Single-phase full-wave operating by BTL output (BTL amplifier gain : +43dB)
- Speed control available by PWM pin
- Built-in Quick Start circuit
- Built-in thermal-shutdown (TSD) circuit
- Hall bias output pin (VHB = 1.05V typ)
- FG(rotation signal) output pin (Open drain output)
- Built-in lock protection and automatic return circuit

Specifications

Absolute Maximum Ratings at Ta = 25°C

Parameter	Symbol	Conditions	Ratings	Unit
Maximum supply voltage	V _{CC} max		7	V
OUT pin output current	I _{OUT} max1	In regular mode	0.7	A
	I _{OUT} max2	In lock-detection mode	1	A
OUT pin output voltage handling	V _{OUT} max		7	V
FG output voltage handling	V _{FG} max		7	V
FG output current	I _{FG} max		5	mA
HB output current	I _{HB} max		10	mA
Allowable power dissipation	Pd max1	Independent IC	0.2	W
	Pd max2	IC on board *	0.4	W
Operating temperature	T _{opr}		-30 to +95	°C
Storage temperature	T _{stg}		-55 to +150	°C

* Specified substrate : 20mm × 10mm × 0.8mm, Paper phenol

Caution 1) Absolute maximum ratings represent the value which cannot be exceeded for any length of time.

Caution 2) Even when the device is used within the range of absolute maximum ratings, as a result of continuous usage under high temperature, high current, high voltage, or drastic temperature change, the reliability of the IC may be degraded. Please contact us for the further details.

Stresses exceeding Maximum Ratings may damage the device. Maximum Ratings are stress ratings only. Functional operation above the Recommended Operating Conditions is not implied. Extended exposure to stresses above the Recommended Operating Conditions may affect device reliability.

LV8063FA

Recommended Operating Conditions at Ta = 25°C

Parameter	Symbol	Conditions	Ratings	Unit
Supply voltage	V _{CC} opg	Active at all circuit	2.5 to 6.0	V
	V _{CC} min	Start-up with PWM=H	2.2 to 6.0	V
Hall input common-mode input voltage range	V _{ICM}		0.3 to V _{CC} -1.5	V

Electrical Characteristics at Ta = 25°C, V_{CC} = 5V

Parameter	Symbol	Conditions	Ratings			Unit
			min	typ	max	
Circuit current	I _{CC}	Active		1.5	3.0	mA
	I _{CCO}	Stand-by		200	300	μA
HB bias voltage	V _{HB}	I _{HB} = 5mA	0.9	1.05	1.2	V
Hall input bias current	I _{HIN}				1	μA
Output On voltage	V _O	I _O = 250mA, source + sink		0.25	0.35	V
Hall amplifier output offset voltage	V _{IN} OFS		-6		6	mV
Hall amplifier voltage gain	GH		39	43	47	dB
PWM pin input Low level	V _{PWML}		0		0.7	V
PWM pin input High level	V _{PWMH}		2.5		V _{CC}	V
PWM input frequency	f _{PWM}	Design guarantee *	20		50	kHz
PWM input smallest pulse width	T _{PWM}	Design guarantee *		5		μs
FG output low-level voltag	V _{FG}	I _{FG} = 3mA			0.3	V
FG output leakage current	I _{FGL}	V _{FG} = 7V			10	μA
FG comparator hysteresis width	ΔV _{HYS}		±5	±15	±20	mV
Output on time in Lock-detection	T _{ACT}		0.45	0.6	0.75	sec
Output off time in Lock-detection	T _{DET}		4.5	6	7.5	sec
Output on/off ratio in Lock-detection	T _{RTO}	T _{RTO} =T _{DET} /T _{ACT}	8	10	11	
Thermal shutdown operating temperature	T _{SD}	Design guarantee *		180		°C
Thermal shutdown hysteresis width	ΔT _{SD}	Design guarantee *		40		°C

* Design guarantee: Indicates a design target value. These parameters are not tested in the independent IC.

Pin Assignment

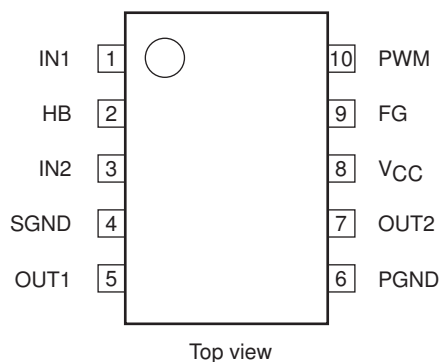

LV8063FA

Package Dimensions

unit : mm (typ)

3428

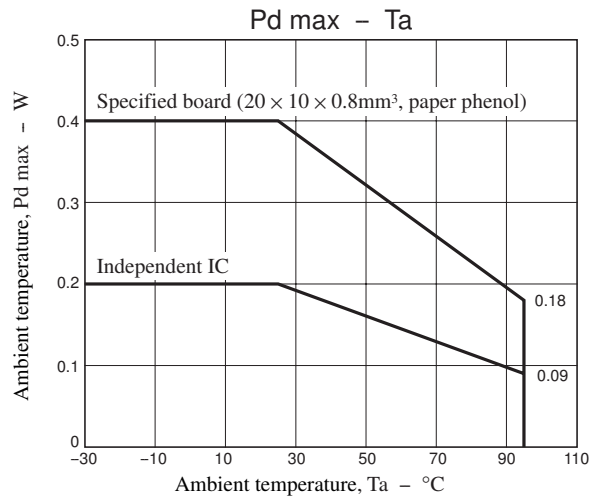
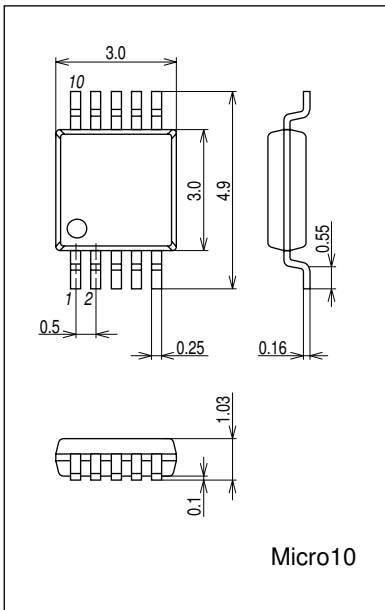

Block Diagram

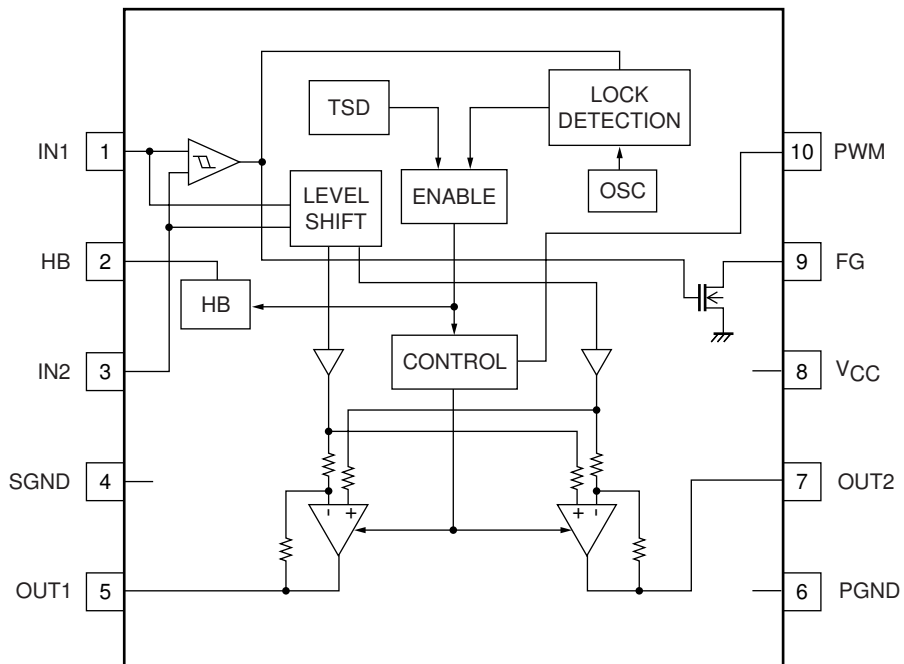

LV8063FA

Sample Application Circuit

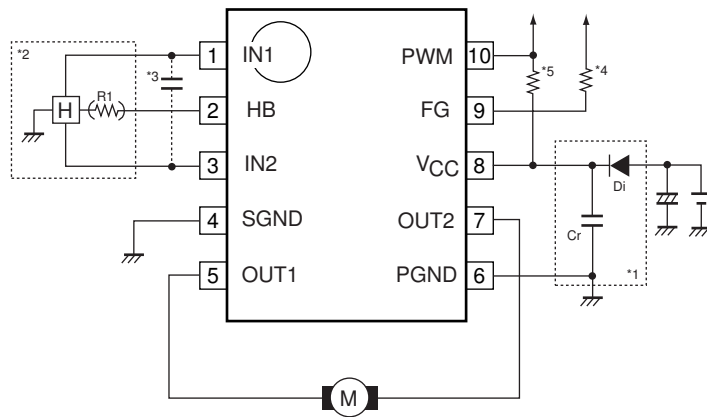

- *1 When the diode D_i is used to prevent device destruction from reverse connection, the capacitor C_r must be inserted to assure a path for regenerative currents.
Similarly, if there no nearby capacitors on the fan power supply line, the capacitor C_r is also required to increase reliability.
- *2 The Hall element is biased at a constant voltage of approximately 1.05V from the HB pin.
Thus LV8063TT provides a stable Hall output with excellent temperature characteristics.
If the Hall output is needed to adjust the amplitude, use the resistor R_1 as shown in the figure.
- *3 When the wiring from the Hall output to IC Hall input is long, noise may be carried through the wiring. In this case, insert the capacitor as shown in the figure.
- *4 This pin must be left open if unused.
- *5 When a PWM signal seems to be the open collector (a drain) output, please connect suitable pulling up resistance so that a H/L level is decided.

LV8063FA

Pin Description

Pin No.	Pin name	Pin voltage	Description	Equivalent circuit
1	IN1	-	Hall input pin (+)	
3	IN2		Hall input pin (-)	
2	HB	1.05V (typ)	Hall bias output pin	
4	SGND	0V	Signal ground pin	
5	OUT1	-	Motor drive output pin	
7	OUT2			
6	PGND	0V	Power ground pin	
8	V _{CC}	2.5V to 6.0V	Voltage supply pin	
9	FG	-	FG pulse output pin	
10	PWM	-	PWM control input pin	

Timing Chart

Stand-by/Start-up

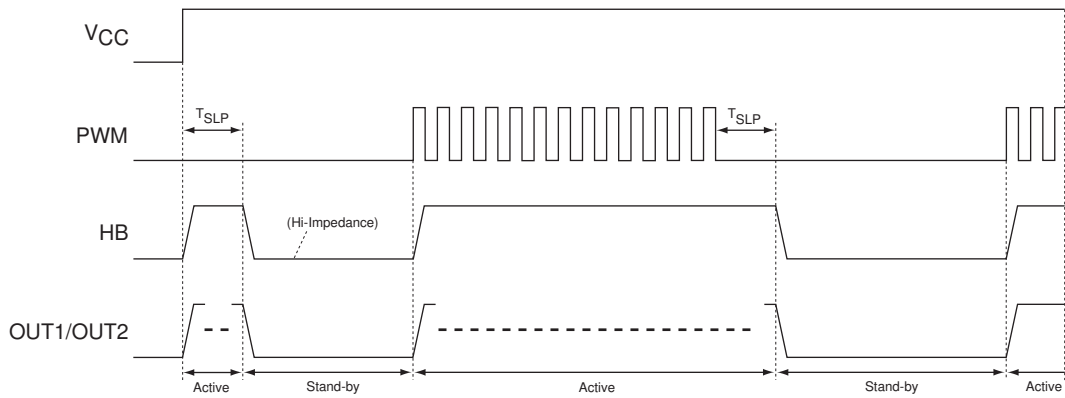

* $T_{SLP}=800\mu s$ (typ)

*When PWM signal is input "L" level for continuousness T_{SLP} , it becomes the Stand-by mode by detecting above situation.

*When "H" level is input, it becomes the Active mode at once.

In Regular-Rotation

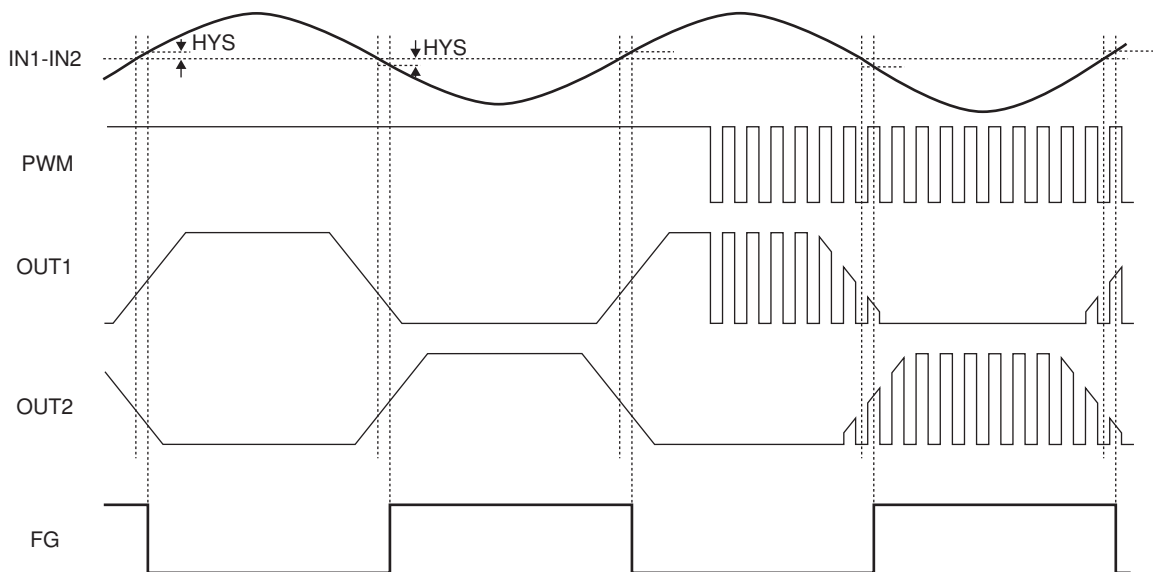

*Truth Table When Steady Rotation

IN1	IN2	*PWM	OUT1	OUT2	FG	Mode
H	L	H	H	L	L	drive
		L	L	L		regeneration
L	H	H	L	H	OFF	drive
		L	L	L		regeneration

In Motor-Lock

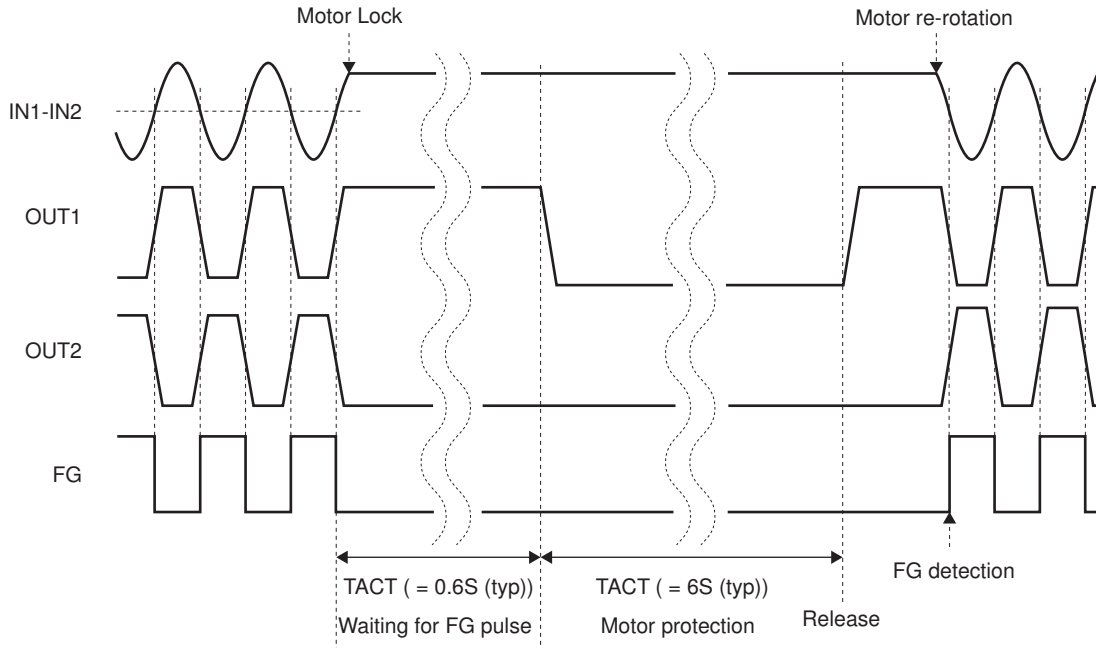

* When motor protection is activated, both OUT1 and OUT2 output low level.

When the circuit operates making amends starting (PWM pin = H)

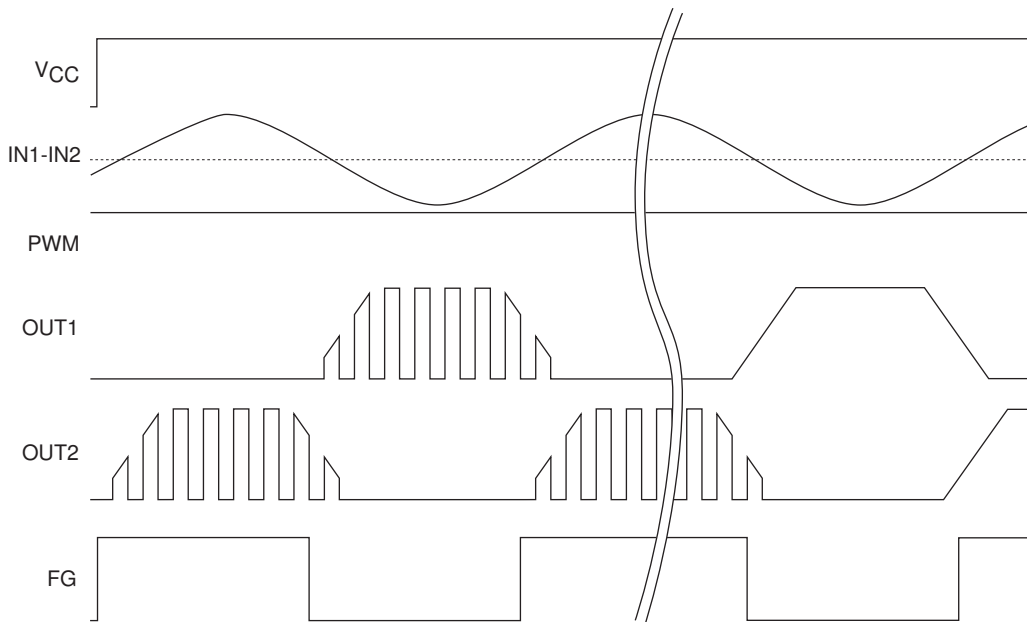

When the power supply is turned on, the standby release (quick start), and the lock protection is released, the start amends operation is done.

LV8063FA

When the circuit operates making amends starting (PWM pin = PWM signal input)

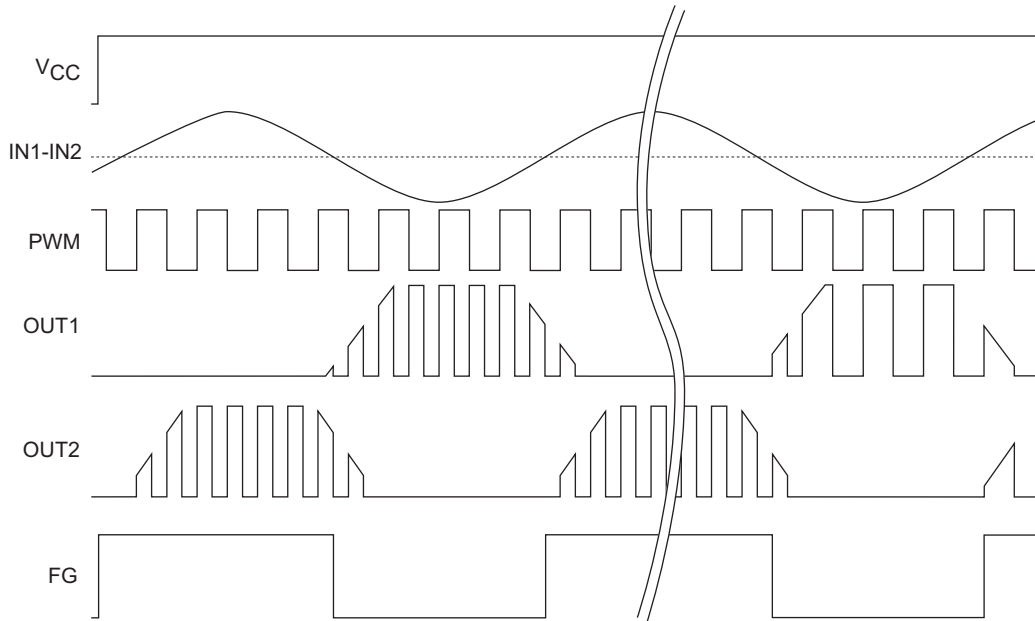

When the power supply is turned on, the standby release (quick start), and the lock protection is released, the start amends operation is done.

ON Semiconductor and the ON logo are registered trademarks of Semiconductor Components Industries, LLC (SCILLC). SCILLC owns the rights to a number of patents, trademarks, copyrights, trade secrets, and other intellectual property. A listing of SCILLC's product/patent coverage may be accessed at www.onsemi.com/site/pdf/Patent-Marking.pdf. SCILLC reserves the right to make changes without further notice to any products herein. SCILLC makes no warranty, representation or guarantee regarding the suitability of its products for any particular purpose, nor does SCILLC assume any liability arising out of the application or use of any product or circuit, and specifically disclaims any and all liability, including without limitation special, consequential or incidental damages. "Typical" parameters which may be provided in SCILLC data sheets and/or specifications can and do vary in different applications and actual performance may vary over time. All operating parameters, including "Typicals" must be validated for each customer application by customer's technical experts. SCILLC does not convey any license under its patent rights nor the rights of others. SCILLC products are not designed, intended, or authorized for use as components in systems intended for surgical implant into the body, or other applications intended to support or sustain life, or for any other application in which the failure of the SCILLC product could create a situation where personal injury or death may occur. Should Buyer purchase or use SCILLC products for any such unintended or unauthorized application, Buyer shall indemnify and hold SCILLC and its officers, employees, subsidiaries, affiliates, and distributors harmless against all claims, costs, damages, and expenses, and reasonable attorney fees arising out of, directly or indirectly, any claim of personal injury or death associated with such unintended or unauthorized use, even if such claim alleges that SCILLC was negligent regarding the design or manufacture of the part. SCILLC is an Equal Opportunity/Affirmative Action Employer. This literature is subject to all applicable copyright laws and is not for resale in any manner.