



ON Semiconductor®

<http://onsemi.com>

# LB11683V

---

## Monolithic Digital IC

### Three-Phase Sensorless Motor Driver

#### Overview

The LB11683V is a three-phase full-wave current-linear-drive motor driver IC. It adopts a sensorless control system without the use of a Hall effect device. For quieter operation, the LB11683V features a current soft switching circuit and is optimal for driving the cooling fan motors used in refrigerators, etc.

#### Functions

- Current linear drive
- Built-in current limiter circuit
- Output stage oversaturation prevention circuit
- Coil counter-electromotive FG output
- Built-in thermal shutdown circuit
- Beat lock prevention circuit
- Lock protection circuit
- Lock detection output

#### Specifications

**Absolute Maximum Ratings** at  $T_a = 25^\circ\text{C}$

Parameter	Symbol	Conditions	Ratings	Unit
Supply voltage	$V_{CC}$ max		14.5	V
Output applied voltage	$V_O$ max		14.5	V
Input applied voltage	$V_I$ max		-0.3 to $V_{CC}+0.3$	V
Output current	$I_O$ max		1.5	A
Allowable power dissipation	$P_d$ max	Independent IC	0.5	W
Operating temperature	$T_{opr}$		-30 to +85	$^\circ\text{C}$
Storage temperature	$T_{stg}$		-55 to +150	$^\circ\text{C}$

Stresses exceeding Maximum Ratings may damage the device. Maximum Ratings are stress ratings only. Functional operation above the Recommended Operating Conditions is not implied. Extended exposure to stresses above the Recommended Operating Conditions may affect device reliability.

# LB11683V

## Allowable Operating Conditions at $T_a = 25^\circ\text{C}$

Parameter	Symbol	Conditions	Ratings	Unit
Supply voltage 1	$V_{CC}$	All operating circuits other than internal 5V Reg.	5.5 to 7.0	V
Supply voltage 2	$V_{CC}$	All operating circuits.	7.0 to 13.8	V

## Electrical Characteristics at $T_a = 25^\circ\text{C}$ , $V_{CC} = 12\text{V}$

Parameter	Symbol	Conditions	Ratings			Unit
			min	typ	max	
Supply current	$I_{CC}$	$V_C=V_{CC}$ $V_{FC}=0\text{V}$		10	15	mA
Output saturation voltage 1	$V_{OSAT1}$	$I_O=0.4\text{A}$ , Source+Sink		1.4	2.0	V
Output saturation voltage 2	$V_{OSAT2}$	$I_O=0.8\text{A}$ , Source+Sink, $R_F=0\Omega$		1.8	2.6	V
MCOM pin common-phase input voltage range	VIC		0		$V_{CC}-2$	V
PCOUT output current 1	IPCOU	Source side		-90		$\mu\text{A}$
PCOUT output current 2	IPCOD	Sink side		90		$\mu\text{A}$
VCOIN input current	IVCOIN	$V_{COIN}=5\text{V}$		0.1	0.2	$\mu\text{A}$
VCO minimum frequency	$f_{VCOMIN}$	$V_{COIN}=\text{open}$ $C_X=0.022\mu\text{F}$	330	400	500	Hz
VCO maximum frequency	$f_{VCOMAX}$	$V_{COIN}=5\text{V}$ $C_X=0.022\mu\text{F}$	14.8	18.5	22.3	kHz
C1, C2 source current ratio	RSOURCE	$1-(I_{C1SOURCE}/I_{C2SOURCE})$	-12		+12	%
C1, C2 sink current ratio	RSINK	$1-(I_{C1SINK}/I_{C2SINK})$	-12		+12	%
C1 source, sink current ratio	RC1	$I_{C1SOURCE}/I_{C1SINK}$		50		%
C2 source, sink current ratio	RC2	$I_{C2SOURCE}/I_{C2SINK}$		50		%
Counter-electromotive FG output ON voltage	VOL	$I_{FGO}=1\text{mA}$			0.4	V
CT pin charge current	ICT1	Source current	1.2	1.6		$\mu\text{A}$
CT pin discharge current	ICT2	Sink current	50	77		nA
Lock protection detection voltage	VRD1		2.3	2.45	2.6	V
Lock protection reset voltage	VRD2		1.13	1.26	1.39	V
RD pin leak current	IRDLEAK				10	$\mu\text{A}$
RD pin output $L_O$ voltage	VRDL	$I_O=1\text{mA}$		100	400	mV
Current limiter setting voltage			0.45	0.5	0.55	V
Thermal shutdown operating temperature	TTSD	Design target *	150	180	210	$^\circ\text{C}$
Thermal shutdown hysteresis	$\Delta\text{TTSD}$	Design target *		15		$^\circ\text{C}$

\*: Design target value and no measurement is made.

# LB11683V

## Package Dimensions

unit : mm (typ)

3315

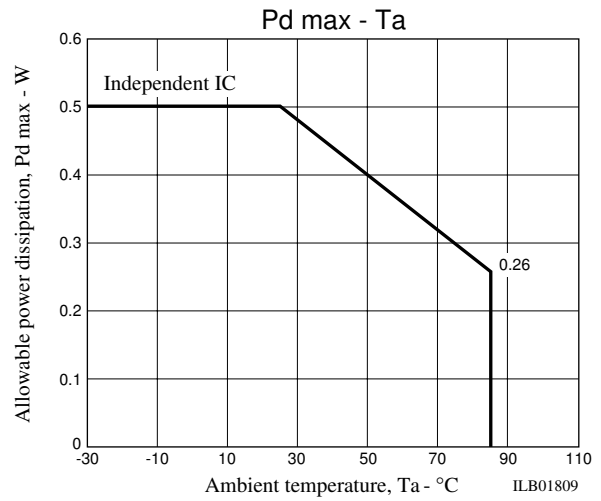
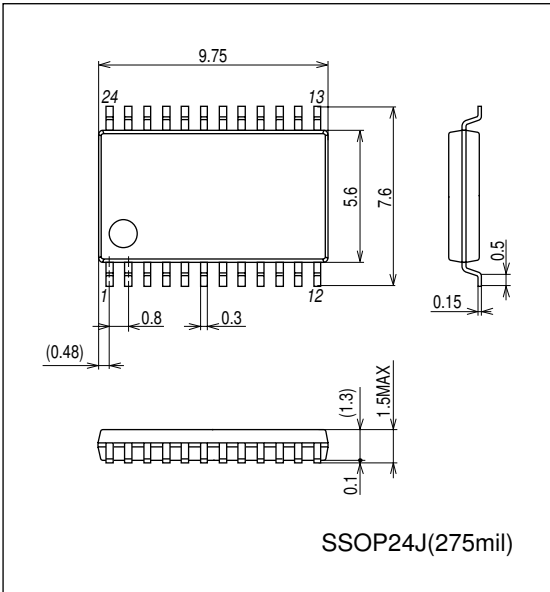

## Pin Assignment

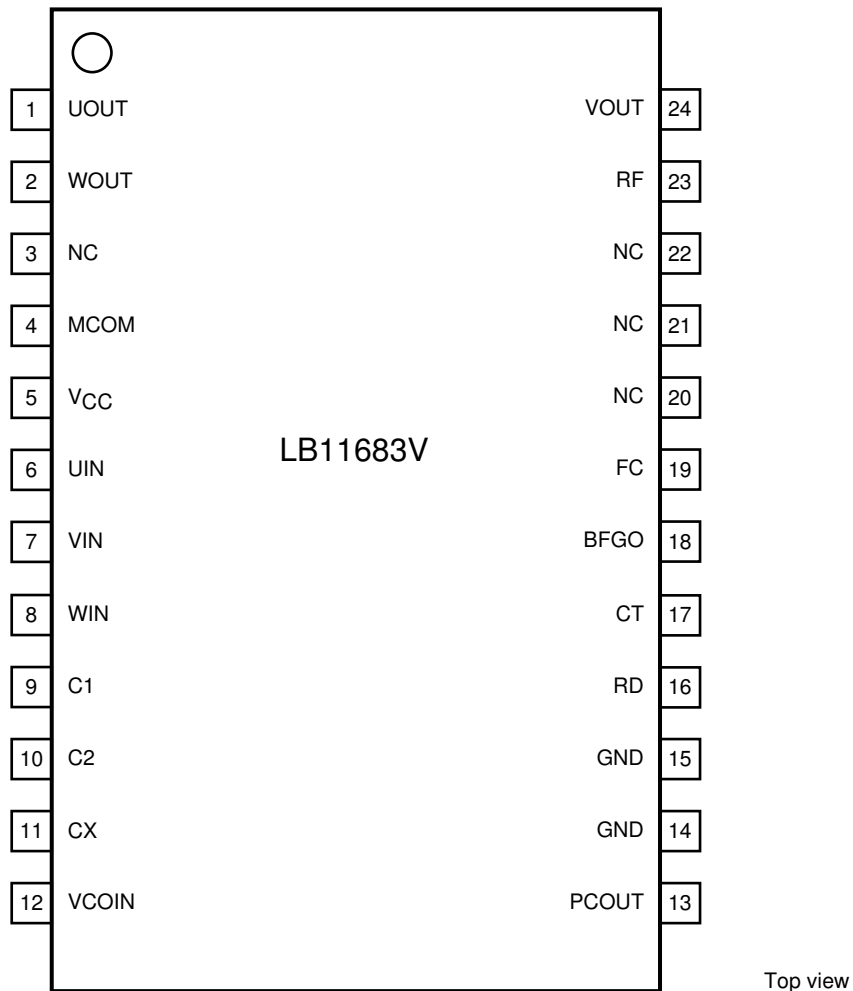

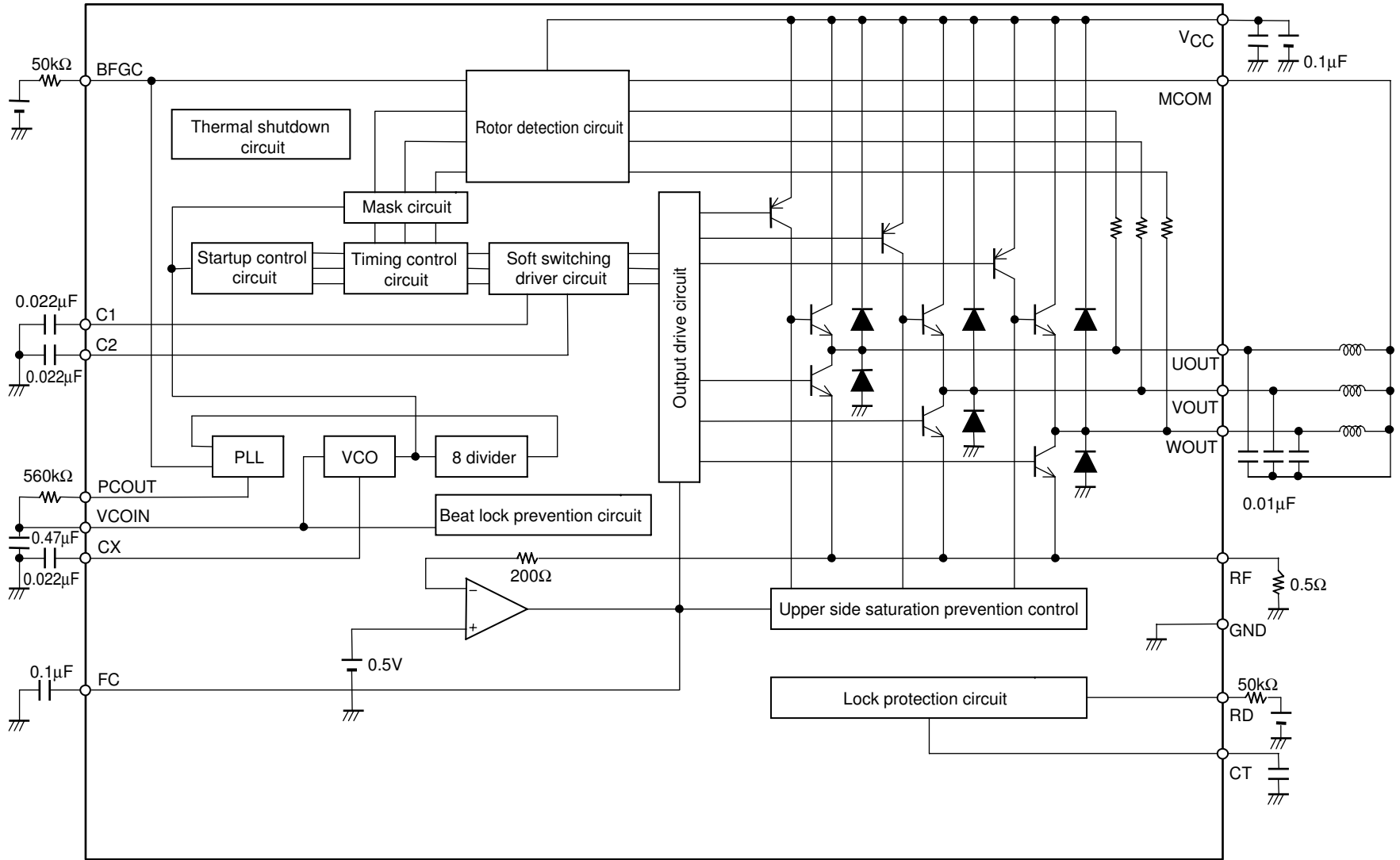

ILB01810

# LB11683V

## Pin Functions

Pin No.	Symbol	Pin Voltage	Equivalent Circuit Diagram	Description
24	UOUT			3-phase motor driver output
1	VOUT			Minimum potential of 3-phase motor driver output transistor.
2	WOUT			Constant current control is made through detection of this voltage. The current limiter also functions by detecting this potential.
5	VCC	8 to 13.8V		Power supply
4	MCOM			Motor coil neutral point input pin. The coil voltage waveform is detected with reference to this voltage.
6	UIN			Coil waveform detection comparator input pin.
7	VIN			This pin is connected to each phase output through the internal 10kΩ resistor.
8	WIN			
9	C1			Triangular wave generating capacitor connection pin. This triangular wave performs soft-switching of the coil output waveforms.
10	C2			
11	CX			In the VCO circuit, the operation frequency range and minimum operation frequency are determined by means of the capacitor value connected this pin and ground.
12	VCOIN			VCO circuit voltage input pin. The PCOUT pin voltage is input via CR filter.

Continued on next page.

# LB11683V

Continued from preceding page.

Pin No.	Symbol	Pin Voltage	Equivalent Circuit Diagram	Description
13	PCOUT			VCO circuit PLL output
14 15	GND			Ground for all other than the output transistor
18	BFGO			Motor counter-electromotive voltage detection FG output (single-phase only). Open collector output
19	FC			Frequency characteristics compensation pin. Insertion of a capacitor between this pin and ground stops oscillation of the closed loop of current control system.
16	RD			Lock detection output. When motor is running: low-level When motor is locked: high-level Open collector output
17	CT			Lock protection ON/OFF time setting capacitor connection pin. The capacitor connected between this pin and ground determines the driver ON/OFF time when the motor is locked.

ON Semiconductor and the ON logo are registered trademarks of Semiconductor Components Industries, LLC (SCILLC). SCILLC owns the rights to a number of patents, trademarks, copyrights, trade secrets, and other intellectual property. A listing of SCILLC's product/patent coverage may be accessed at [www.onsemi.com/site/pdf/Patent-Marking.pdf](http://www.onsemi.com/site/pdf/Patent-Marking.pdf). SCILLC reserves the right to make changes without further notice to any products herein. SCILLC makes no warranty, representation or guarantee regarding the suitability of its products for any particular purpose, nor does SCILLC assume any liability arising out of the application or use of any product or circuit, and specifically disclaims any and all liability, including without limitation special, consequential or incidental damages. "Typical" parameters which may be provided in SCILLC data sheets and/or specifications can and do vary in different applications and actual performance may vary over time. All operating parameters, including "Typicals" must be validated for each customer application by customer's technical experts. SCILLC does not convey any license under its patent rights nor the rights of others. SCILLC products are not designed, intended, or authorized for use as components in systems intended for surgical implant into the body, or other applications intended to support or sustain life, or for any other application in which the failure of the SCILLC product could create a situation where personal injury or death may occur. Should Buyer purchase or use SCILLC products for any such unintended or unauthorized application, Buyer shall indemnify and hold SCILLC and its officers, employees, subsidiaries, affiliates, and distributors harmless against all claims, costs, damages, and expenses, and reasonable attorney fees arising out of, directly or indirectly, any claim of personal injury or death associated with such unintended or unauthorized use, even if such claim alleges that SCILLC was negligent regarding the design or manufacture of the part. SCILLC is an Equal Opportunity/Affirmative Action Employer. This literature is subject to all applicable copyright laws and is not for resale in any manner.