



ON Semiconductor®

<http://onsemi.com>

LB1936V

Monolithic Digital IC

1-2 Phase Excitation Stepping Motor Driver

Overview

The LB1936V is a 2-phase bipolar drive stepping motor driver IC that supports low-voltage drive. The LB1936V's miniature package and minimal number of external components reduces the required mounting area. It also provides high-efficiency motor drive and can reduce circuit current consumption. Since it provides a current detection pin and supports PWM control input, it can be used to implement current chopper control at the system level. The LB1936V is optimal for the stepping motor drive in scanners, digital cameras, and printers.

Features

- Low saturation voltage forward/reverse motor driver ($V_{O\ sat} = 0.25V$ at $I_O = 200mA$)
- Two H-bridge channels
- Wide usable voltage range (Allowable voltage range : 2.5V to 9.5V, absolute maximum rating : 10.5V)
- Supports PWM input (Low power consumption can be achieved in slow delay mode that uses $IN1/IN2 = H/H$ logic.)
- Motor (coil) current detection pin
- Built-in thermal shutdown circuit
- Miniature package (SSOP16 : 225mil)

Specifications

Absolute Maximum Ratings at $T_a = 25^\circ C$

Parameter	Symbol	Conditions	Ratings	Unit
Maximum supply voltage	$V_{CC\ max}$		-0.3 to +10.5	V
	$V_S\ max$		-0.3 to +10.5	V
Maximum output voltage	$V_{OUT\ max}$		$V_S + V_{SF}$	V
Maximum input voltage	$V_{IN\ max}$		-0.3 to +8.0	V
Ground pin source current	$I_{GND\ max}$	Per channel	800	mA
Allowable power dissipation	$P_d\ max$	When mounted on a circuit board *	740	mW
Operating temperature	T_{opr}		-20 to +85	$^\circ C$
Storage temperature	T_{stg}		-40 to +150	$^\circ C$

* Specified circuit board : $114.3 \times 76.1 \times 1.6mm^3$, glass epoxy

Stresses exceeding Maximum Ratings may damage the device. Maximum Ratings are stress ratings only. Functional operation above the Recommended Operating Conditions is not implied. Extended exposure to stresses above the Recommended Operating Conditions may affect device reliability.

LB1936V

Allowable Operating Range at $T_a = 25^\circ\text{C}$

Parameter	Symbol	Conditions	Ratings	Unit
Supply voltage	V_{CC}		2.5 to 9.5	V
	V_S		2.5 to 9.5	
High-level input voltage	V_{IH}		2.0 to 7.5	V
Low-level input voltage	V_{IL}		-0.3 to 0.7	V

Electrical Characteristics at $T_a = 25^\circ\text{C}$, $V_{CC} = V_S = 5\text{V}$

Parameter	Symbol	Conditions	Ratings			Unit
			min	typ	max	
V_{CC} system power supply current	I_{CC0}	$IN1 = IN2 = IN3 = IN4 = 0\text{V}$		0.1	1	μA
	I_{CC1}	$IN1 = IN3 = 3\text{V}$, $IN2 = IN4 = 0\text{V}$		10	16	mA
VS system power supply current	I_{S0}	$IN1 = IN2 = IN3 = IN4 = 0\text{V}$		0.1	1	μA
	I_{S1}	$IN1 = IN3 = 3\text{V}$, $IN2 = IN4 = 0\text{V}$		12	19	mA
Output saturation voltage	V_{OUT1}	$V_{CC} = V_S = 3\text{V}$ to 7.5V , $V_{IN} = 3\text{V}$ or 0V , $I_{OUT} = 200\text{mA}$ (High and low side)	-	0.25	0.4	V
	V_{OUT2}	$V_{CC} = V_S = 4\text{V}$ to 7.5V , $V_{IN} = 3\text{V}$ or 0V , $I_{OUT} = 400\text{mA}$ (High and low side)	-	0.5	0.8	V
Input current	I_{IN}	$V_{IN} = 5\text{V}$		150	200	μA
Spark killer diode						
Reverse current	$I_S(\text{leak})$				30	μA
Forward voltage	VSF	$I_{OUT} = 400\text{mA}$			1.7	V

Package Dimensions

unit:mm (typ)

3178B

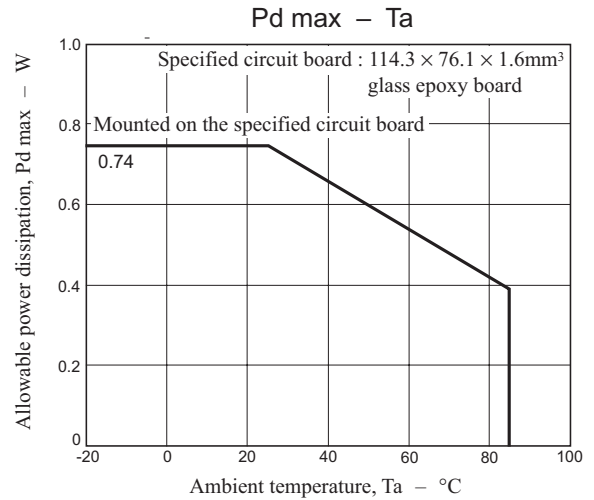
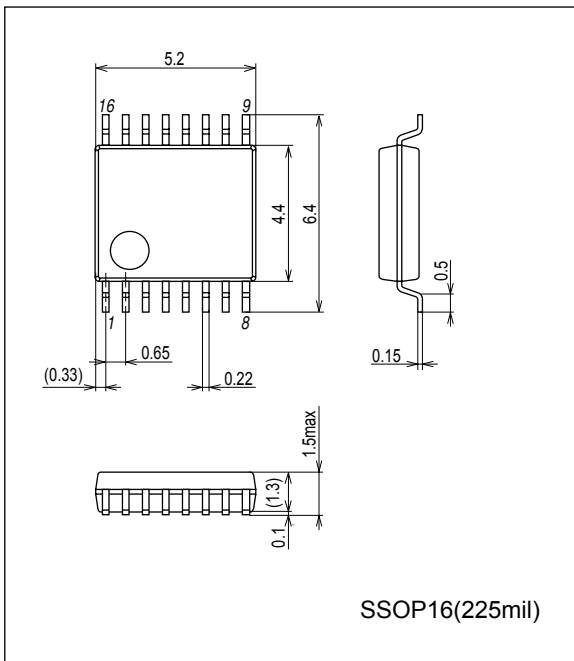

LB1936V

Pin Assignment

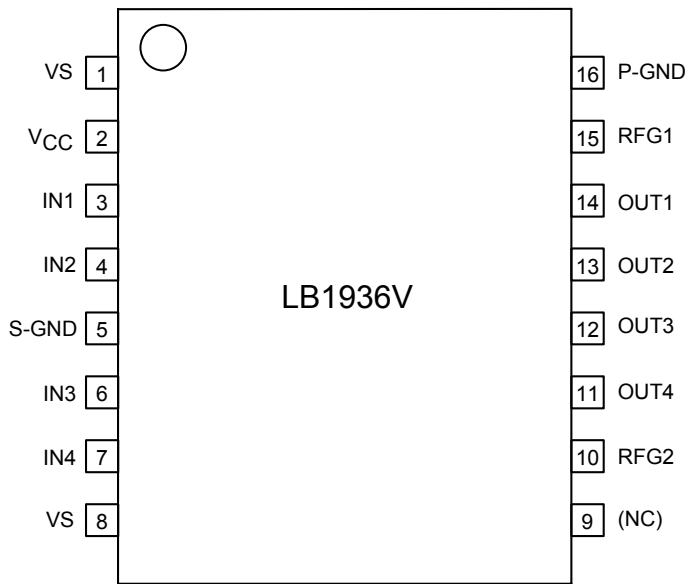

Block Diagram

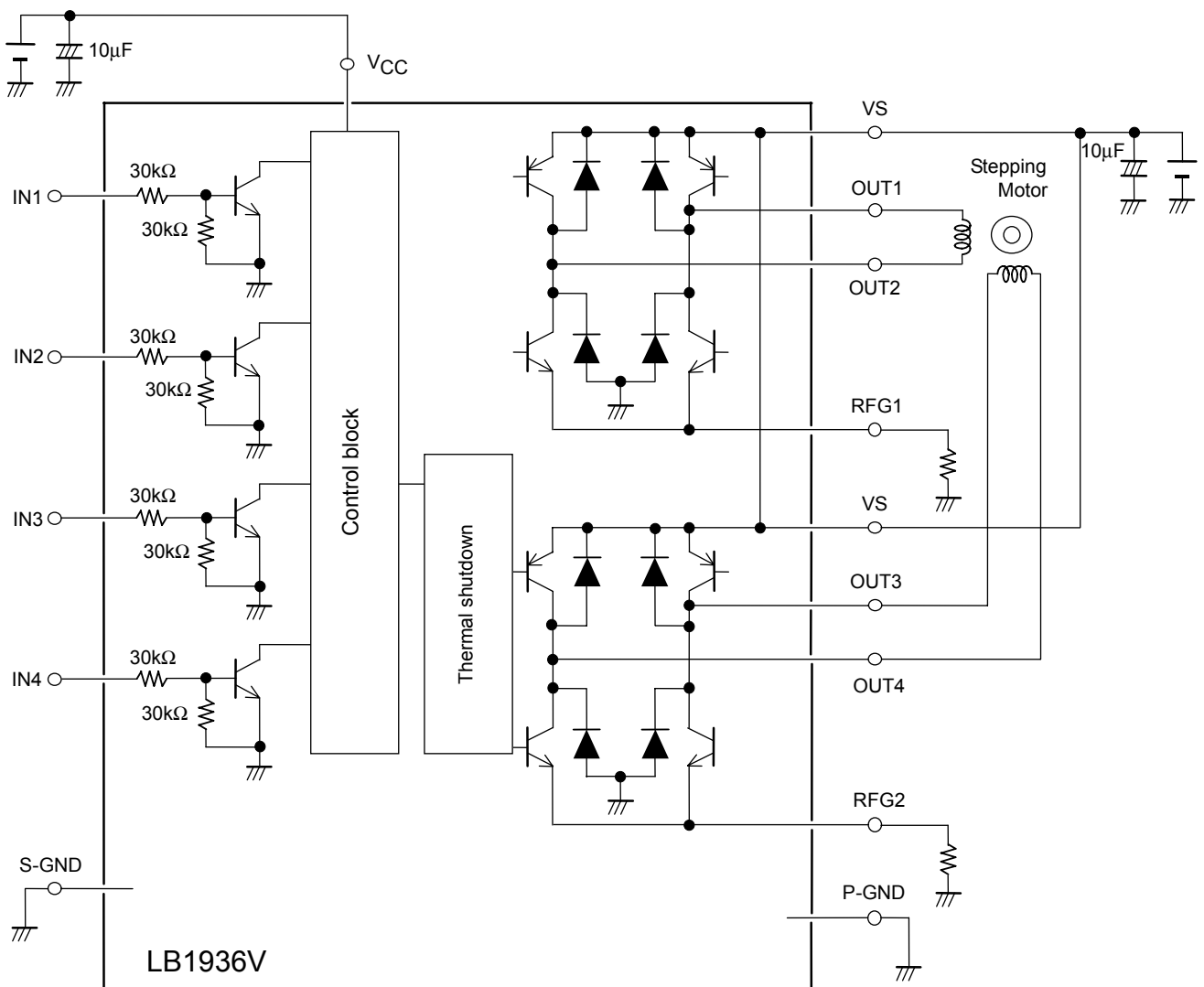

LB1936V

Truth Table

IN1	IN2	IN3	IN4	OUT1	OUT2	OUT3	OUT4	Output mode
L	L	-		off	off	-		(1)
L	H			L	H			(2)
H	L			H	L			(3)
H(*)	H(*)			off	H			(4)
-		-		-		off	off	(5)
						L	H	(6)
						H	L	(7)
						off	H	(8)
-		-		-		H	off	(8)'

L : low, H : high

*: The output logic mode when IN1/IN2 = H/H is determined by the immediately preceding IN1/IN2 mode.

The post-switching output modes will be as follows.

When switching from (2): (4)

When switching from (3): (4)'

When switching from (1): Undefined (Either (4) or (4)')

The modes when IN3/IN4 = H/H operate similarly as described below.

When switching from (6): (8)

When switching from (7): (8)'

When switching from (5): Undefined (Either (8) or (8)')

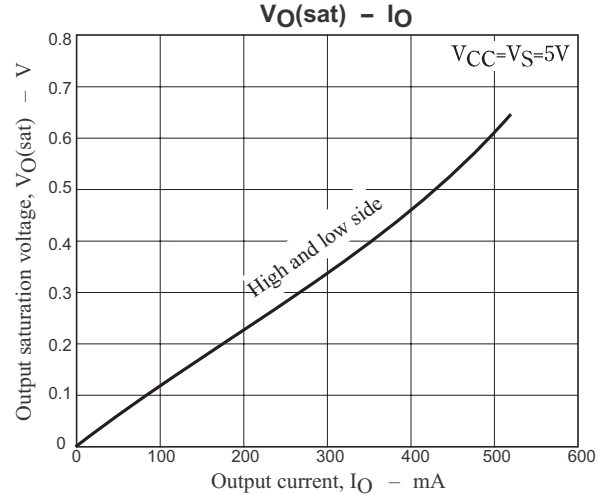
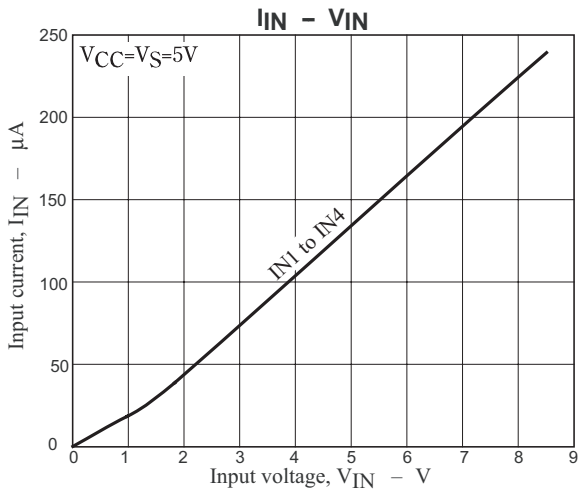
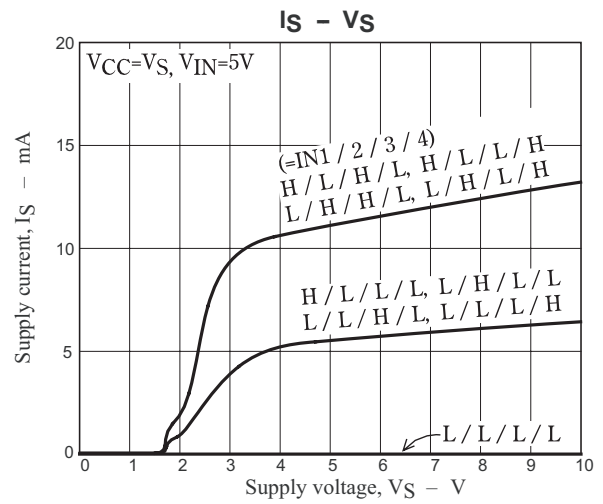
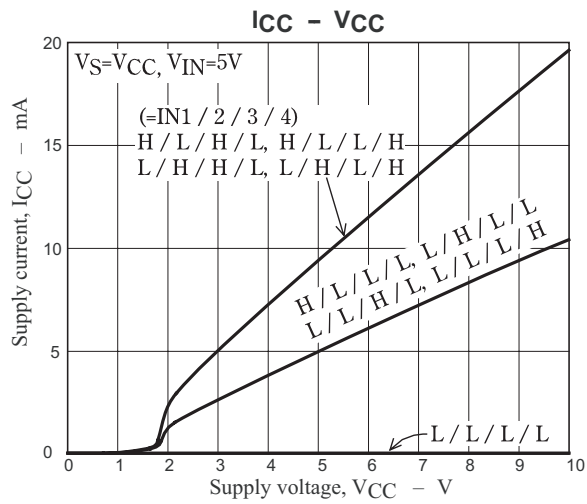

LB1936V

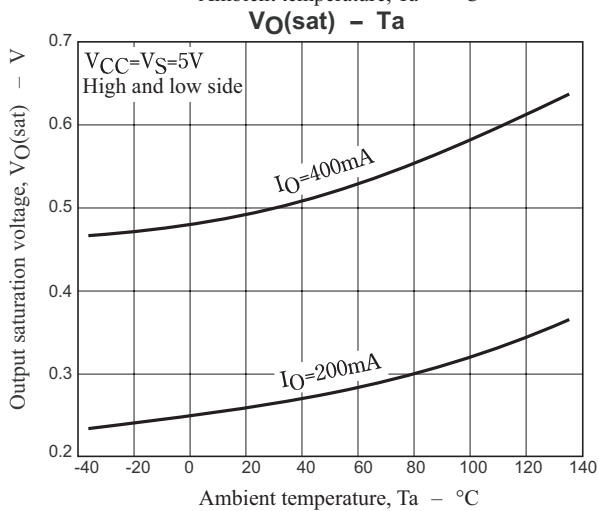
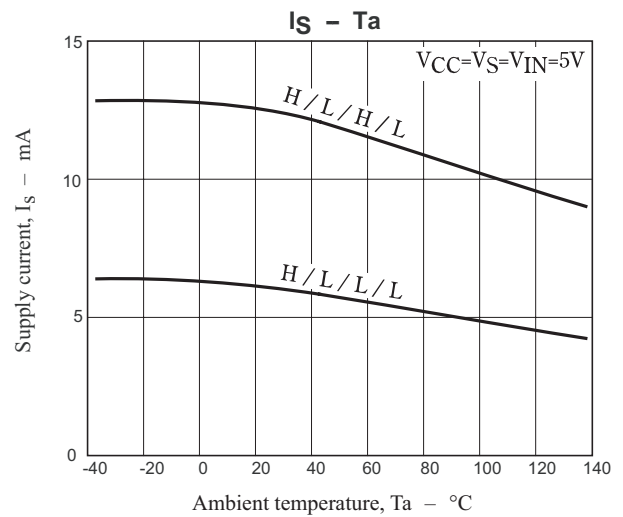
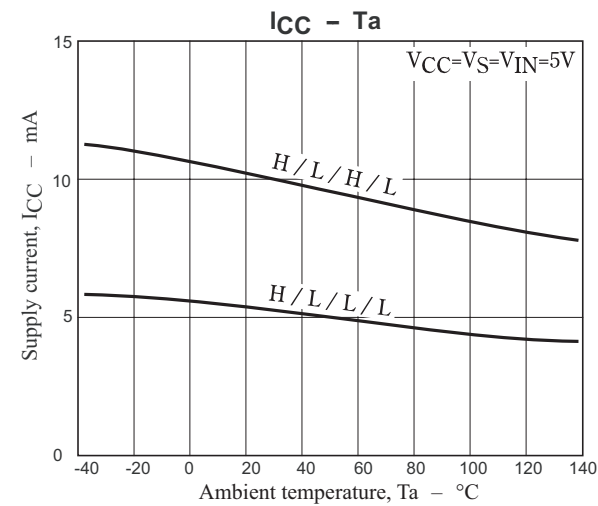

ON Semiconductor and the ON logo are registered trademarks of Semiconductor Components Industries, LLC (SCILLC). SCILLC owns the rights to a number of patents, trademarks, copyrights, trade secrets, and other intellectual property. A listing of SCILLC's product/patent coverage may be accessed at www.onsemi.com/site/pdf/Patent-Marking.pdf. SCILLC reserves the right to make changes without further notice to any products herein. SCILLC makes no warranty, representation or guarantee regarding the suitability of its products for any particular purpose, nor does SCILLC assume any liability arising out of the application or use of any product or circuit, and specifically disclaims any and all liability, including without limitation special, consequential or incidental damages. "Typical" parameters which may be provided in SCILLC data sheets and/or specifications can and do vary in different applications and actual performance may vary over time. All operating parameters, including "Typicals" must be validated for each customer application by customer's technical experts. SCILLC does not convey any license under its patent rights nor the rights of others. SCILLC products are not designed, intended, or authorized for use as components in systems intended for surgical implant into the body, or other applications intended to support or sustain life, or for any other application in which the failure of the SCILLC product could create a situation where personal injury or death may occur. Should Buyer purchase or use SCILLC products for any such unintended or unauthorized application, Buyer shall indemnify and hold SCILLC and its officers, employees, subsidiaries, affiliates, and distributors harmless against all claims, costs, damages, and expenses, and reasonable attorney fees arising out of, directly or indirectly, any claim of personal injury or death associated with such unintended or unauthorized use, even if such claim alleges that SCILLC was negligent regarding the design or manufacture of the part. SCILLC is an Equal Opportunity/Affirmative Action Employer. This literature is subject to all applicable copyright laws and is not for resale in any manner.