



ON Semiconductor®

<http://onsemi.com>

# LB11948T

Monolithic Digital IC

## PWM Constant Current Control 1-2 Phase Excitation Stepping Motor Driver

### Overview

The LB11948T is a low saturation voltage output PWM current control bipolar drive stepping motor driver. It is optimal for use as the driver for the miniature low-voltage stepping motors used in portable electronic equipment such as portable thermal printers.

### Features

- PWM current control (external excitation)
- Simultaneous on state prevention function (through current prevention)
- Thermal shutdown circuit
- Noise canceller function
- Low-power mode control pin

### Specifications

**Absolute Maximum Ratings** at  $T_a = 25^\circ\text{C}$

Parameter	Symbol	Conditions	Ratings	Unit
VS supply voltage	VS		-0.3 to +18	V
Logic system supply voltage	$V_{CC}$		-0.3 to +18	V
Peak output current	$I_O$ peak	$tW \leq 20\mu\text{S}$	0.5	A
Continuous output current	$I_O$ max		0.4	A
Emitter output voltage	VE		1.0	V
Input voltage	$V_{IN}$		-0.3 to $V_{CC}$	V
Allowable power dissipation	$P_d$ max	Mounted on the specified PCB*	1.2	W
Operating temperature	$T_{opg}$		-20 to +85	$^\circ\text{C}$
Storage temperature	$T_{stg}$		-40 to +150	$^\circ\text{C}$

Note \* : Specified PCB : 114.3×76.1×1.6mm

Stresses exceeding Maximum Ratings may damage the device. Maximum Ratings are stress ratings only. Functional operation above the Recommended Operating Conditions is not implied. Extended exposure to stresses above the Recommended Operating Conditions may affect device reliability.

# LB11948T

## Recommended Operating Conditions at Ta = 25°C

Parameter	Symbol	Conditions	Ratings	Unit
VS supply voltage	VS		3.0 to 15	V
VCC supply voltage	VCC		3.0 to 15	V
Reference voltage	VREF	VCC ≤ 4V	0.0 to 1.0	V
		VCC > 4V	0.0 to 1.5	V

## Electrical Characteristics Ta = 25°C, VS = VCC = 5V, VREF = 0.3V

Parameter	Symbol	Conditions	Ratings			Unit
			min	typ	max	
[Output Block]						
VS system supply current	I <sub>VS</sub> OFF	PH1 = PH2 = 0V, EN1 = EN2 = 3.0V, ST = 3.0V			5	μA
	I <sub>VS</sub> ON	PH1 = PH2 = EN1 = EN2 = 0V, ST = 3.0V	28	40	52	mA
	I <sub>VS</sub> wt	PH1 = PH2 = EN1 = EN2 = ST = 0V			1	μA
Output saturation voltage 1	V <sub>O</sub> (sat) 1	I <sub>O</sub> = +0.2A (source)		0.2	0.4	V
Output saturation voltage 2	V <sub>O</sub> (sat) 2	I <sub>O</sub> = +0.4A (source)		0.3	0.5	V
Output saturation voltage 3	V <sub>O</sub> (sat) 3	I <sub>O</sub> = -0.2A (sink)		0.2	0.4	V
Output saturation voltage 4	V <sub>O</sub> (sat) 4	I <sub>O</sub> = -0.4A (sink)		0.3	0.5	V
Output leakage current	I <sub>O1</sub> (leak)	V <sub>O</sub> = V <sub>BB</sub> (sink)			50	μA
	I <sub>O2</sub> (leak)	V <sub>O</sub> = 0V (source)	-50			μA
Upper and lower side output diodes						
Forward voltage 1 (upper side)	VF1	I = 400mA	0.9	1.1	1.3	V
Forward voltage 2 (lower side)	VF2	I = 400mA	0.9	1.1	1.3	V
[Logic Block]						
VCC system supply current	I <sub>CC</sub> OFF	PH1 = PH2 = 0V, EN1 = EN2 = 3.0V, ST = 3.0V	6.5	10	13.5	mA
	I <sub>CC</sub> ON	PH1 = PH2 = EN1 = EN2 = 0V, ST = 3.0V	7	11	15	mA
	I <sub>CC</sub> wt	PH1 = PH2 = EN1 = EN2 = ST = 0V			1	μA
Input voltage	V <sub>I</sub> on		2.0			V
	V <sub>I</sub> off				0.8	V
Input current	I <sub>IN</sub>	V <sub>IN</sub> = 5V	70	100	130	μA
Reference voltage : 1V	V1V	I <sub>O</sub> = 1mA	0.95	1	1.05	V
Current setting reactive current	IE		-22	-17	-10.5	mA
Reference current	IREF	VREF = 0.3V, VE = 0.3V	-1			μA
CR pin current 1	ICR1	CR = 0.5V	-2			μA
CR pin current 2	ICR2	CR = 3V	1.65	2.2	2.75	mA
Sense voltage 1	VSEN1	VREF = 0.5V	0.475	0.5	0.525	V
Thermal shutdown temperature *	TS	*		170		°C

Note \* : Design guarantee value

## Truth Table

Input	Channel 1				Channel 2			
	Input		Output		Input		Output	
ST	PHASE1	ENABLE1	OUT1 <sup>-</sup>	OUT1	PHASE2	ENABLE2	OUT2 <sup>-</sup>	OUT2
H	L	L	H	L	L	L	H	L
H	H	L	L	H	H	L	L	H
H	*	H	OFF	OFF	*	H	OFF	OFF
L	*	*	OFF	OFF	*	*	OFF	OFF

Note \* : Levels shown as an asterisk (\*) can be set to be either high or low.

# LB11948T

## Package Dimensions

unit : mm (typ)

3259

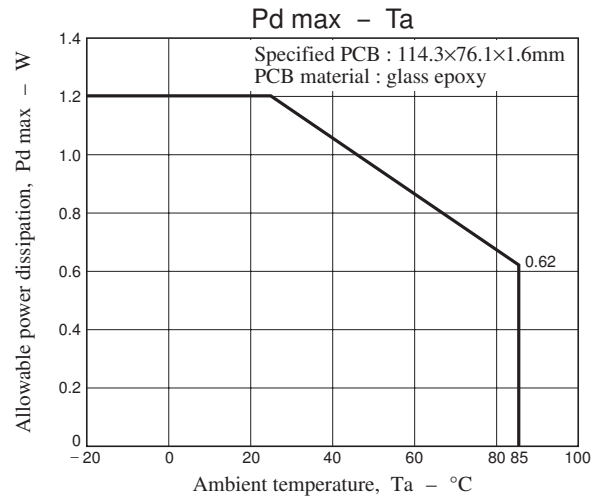
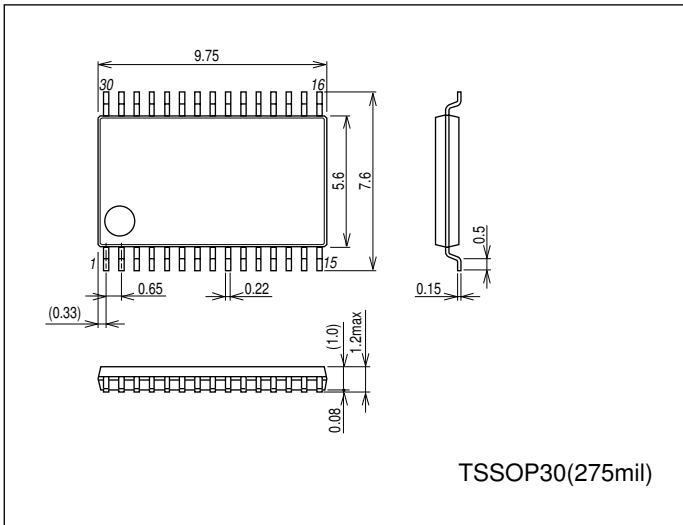

## Pin Assignment

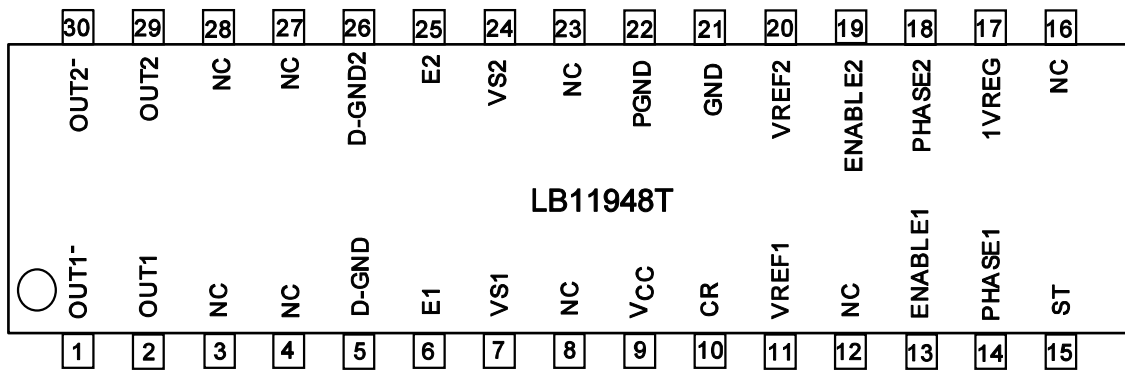

Top view

# LB11948T

## Pin Functions

Pin No.	Pin Name	Description
1	OUT1 <sup>-</sup>	Output
2	OUT1	Output
3	NC	Unused
4	NC	Unused
5	D-GND	Lower side internal diode anode connection
6	E1	Constant current control sensing The motor current is set by the value of the sensing resistor $R_e$ connected between the E1 pin and ground. The current is set according to the following equation : $I_O = V_{REF}/R_e$ (A)
7	VS1	VS power supply
8	NC	Unused
9	V <sub>CC</sub>	V <sub>CC</sub> power supply
10	CR	RC oscillator connection
11	VREF1	Current setting system reference voltage input VREF1 voltage range : 0 to 0.5V
12	NC	Unused
13	ENABLE1	Output is turned on when ENABLE1 is low, and the output is turned off (operating state) when ENABLE1 is high.
14	PHASE1	Logic level input : phase switching When PHASE1 = high : Output pin states : OUT1 : high, OUT1 <sup>-</sup> : low. When PHASE1 = low : Output pin states : OUT1 : low, OUT1 <sup>-</sup> : high.
15	ST	Standby mode setting When ST = high : the IC operates in normal operating mode. When ST = low : the IC operates in standby mode. The VS and V <sub>CC</sub> current drain levels are under 1μA in this mode.
16	NC	Unused
17	1VREG	1V regulator circuit output The LB11948 includes an internal 1V regulator circuit, and this pin is the output from that circuit. The VREF1 and VREF2 reference voltages can be set by voltage dividing the 1V regulator output.
18	PHASE2	Logic level input : phase switching When PHASE2 = high : Output pin states : OUT2 : high, OUT2 <sup>-</sup> : low. When PHASE2 = low : Output pin states : OUT2 : low, OUT2 <sup>-</sup> : high.
19	ENABLE2	Output is turned on when ENABLE2 is low, and the output is turned off (operating state) when ENABLE2 is high.
20	VREF2	Current setting reference voltage input VREF2 voltage range : 0 to 0.5V
21	GND	Ground (small signal circuit system ground)
22	PGND	Power system ground (high current circuit system ground)
23	NC	Unused
24	VS2	VS power supply
25	E2	Constant current control sensing The motor current is set by the value of the sensing resistor $R_e$ connected between the E2 pin and ground. The current is set according to the following equation : $I_O = V_{REF}/R_e$ (A)
26	D-GND2	Lower side internal diode anode connection
27	NC	Unused
28	NC	Unused
29	OUT2	Output
30	OUT2 <sup>-</sup>	Output

# LB11948T

## Block Diagram

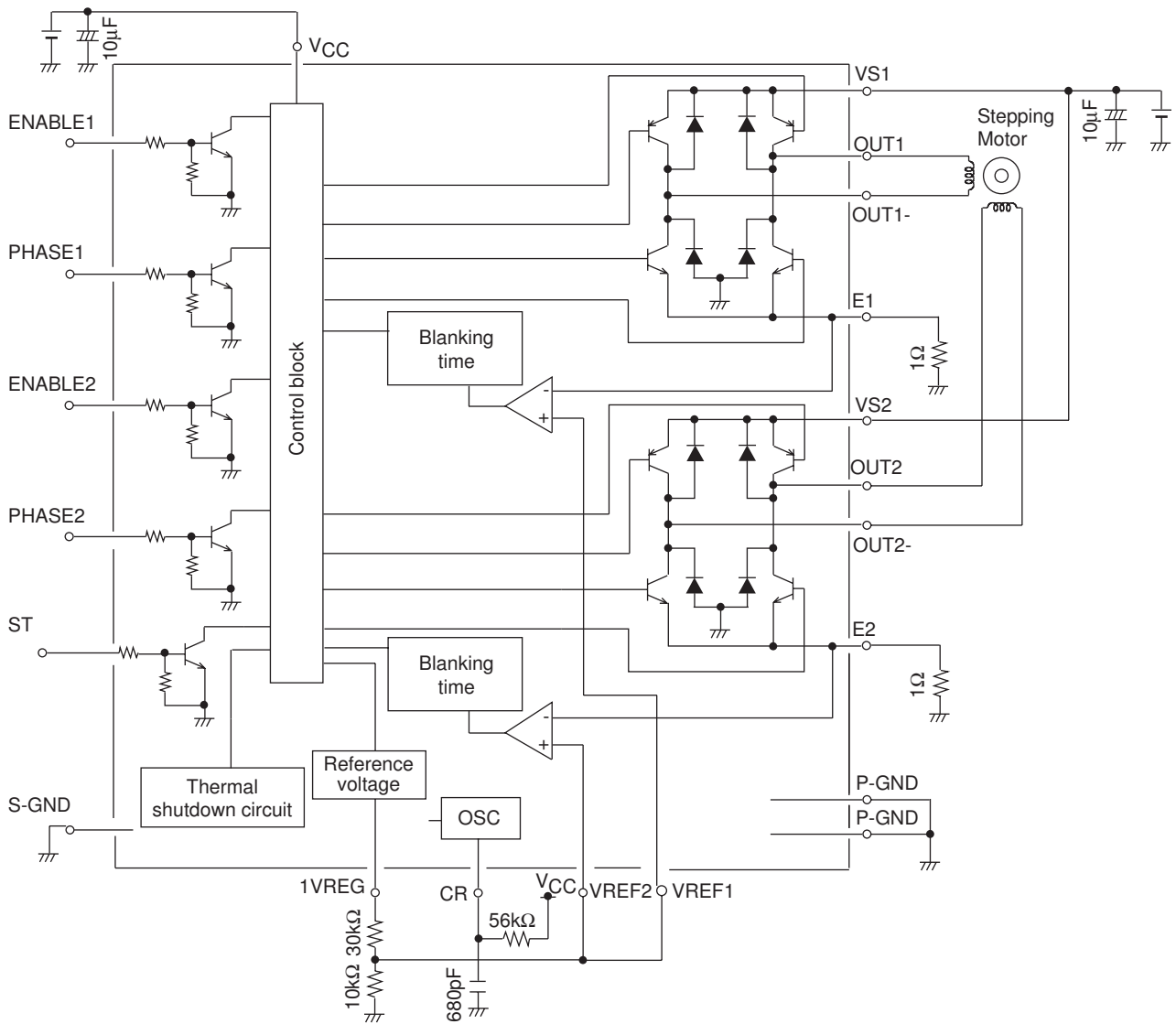

# LB11948T

## Sample Application Circuit

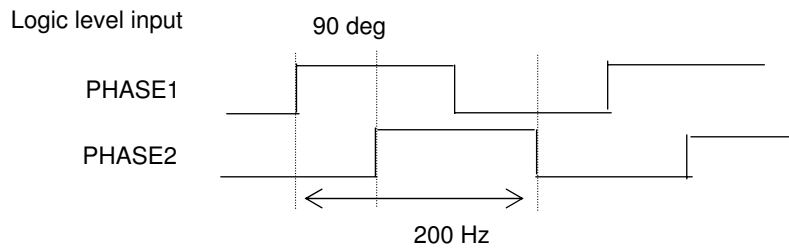
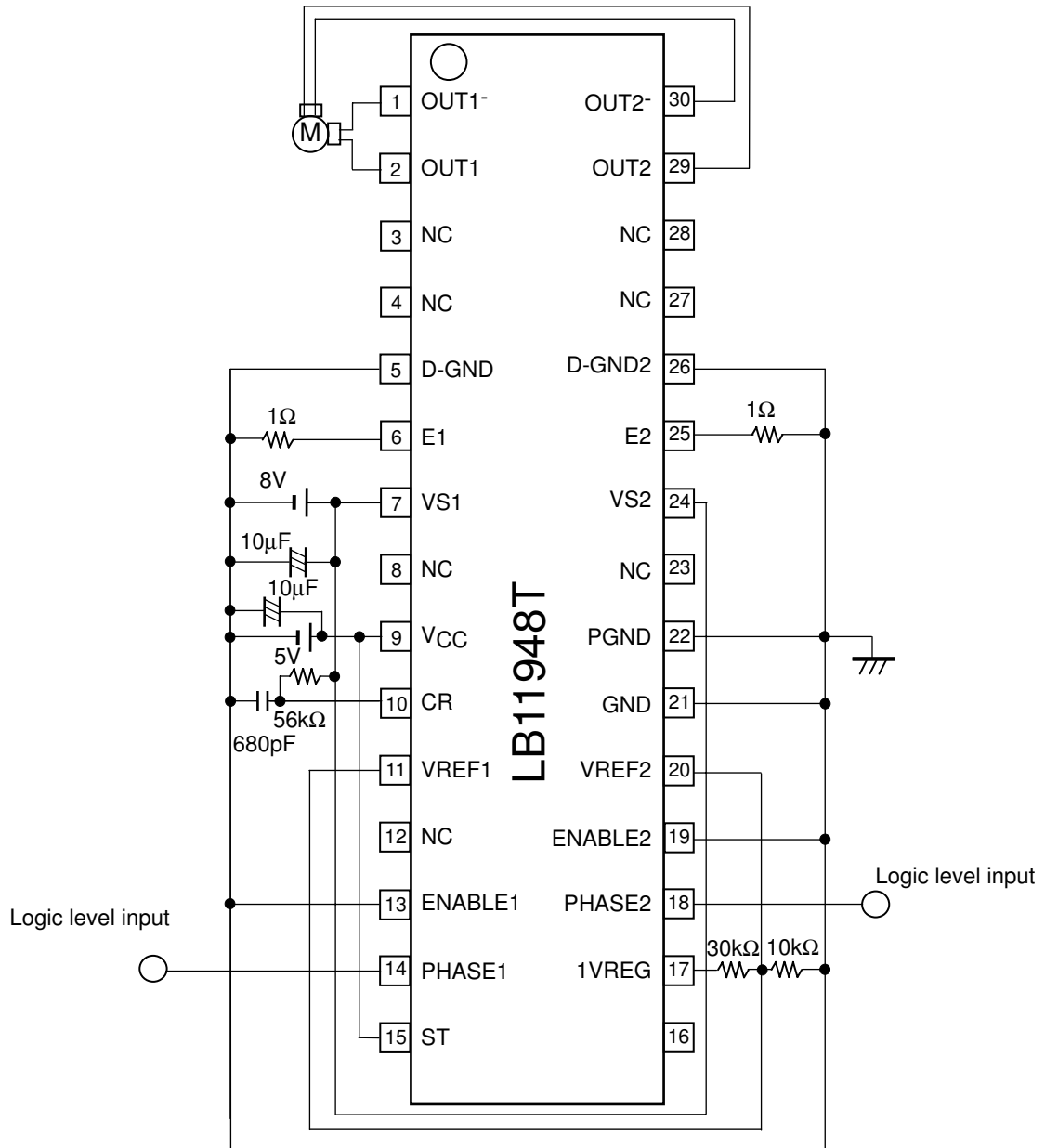

# LB11948T

## Drive Sequence Table 2 Phase Excitation Drive Sequence

Table 1 Clockwise drive

No.	PHASE1	ENABLE1	OUT1	OUT1'	PHASE2	ENABLE2	OUT2	OUT2'
0	0	0	0	1	0	0	0	1
1	1	0	1	0	0	0	0	1
2	1	0	1	0	1	0	1	0
3	0	0	0	1	1	0	1	0

Table 2 Counterclockwise drive

No.	PHASE1	ENABLE1	OUT1	OUT1'	PHASE2	ENABLE2	OUT2	OUT2'
0	0	0	0	1	1	0	1	0
1	1	0	1	0	1	0	1	0
2	1	0	1	0	0	0	0	1
3	0	0	0	1	0	0	0	1

## 1-2 Phase Excitation Drive Sequence

Table 3 Clockwise drive

No.	PHASE1	ENABLE1	OUT1	OUT1'	PHASE2	ENABLE2	OUT2	OUT2'
0	0	0	0	1	0	1	OFF	OFF
1	0	0	0	1	0	0	0	1
2	1	1	OFF	OFF	0	0	0	1
3	1	0	1	0	0	0	0	1
4	1	0	1	0	1	1	OFF	OFF
5	1	0	1	0	1	0	1	0
6	0	1	OFF	OFF	1	0	1	0
7	0	0	0	1	1	0	1	0

Table 4 Counterclockwise drive

No.	PHASE1	ENABLE1	OUT1	OUT1'	PHASE2	ENABLE2	OUT2	OUT2'
0	0	0	0	1	1	1	OFF	OFF
1	0	0	0	1	1	0	1	0
2	1	1	OFF	OFF	1	0	1	0
3	1	0	1	0	1	0	1	0
4	1	0	1	0	0	1	OFF	OFF
5	1	0	1	0	0	0	0	1
6	0	1	OFF	OFF	0	0	0	1
7	0	0	0	1	0	0	0	1

# LB11948T

## 2 Phase Excitation Drive Sequence

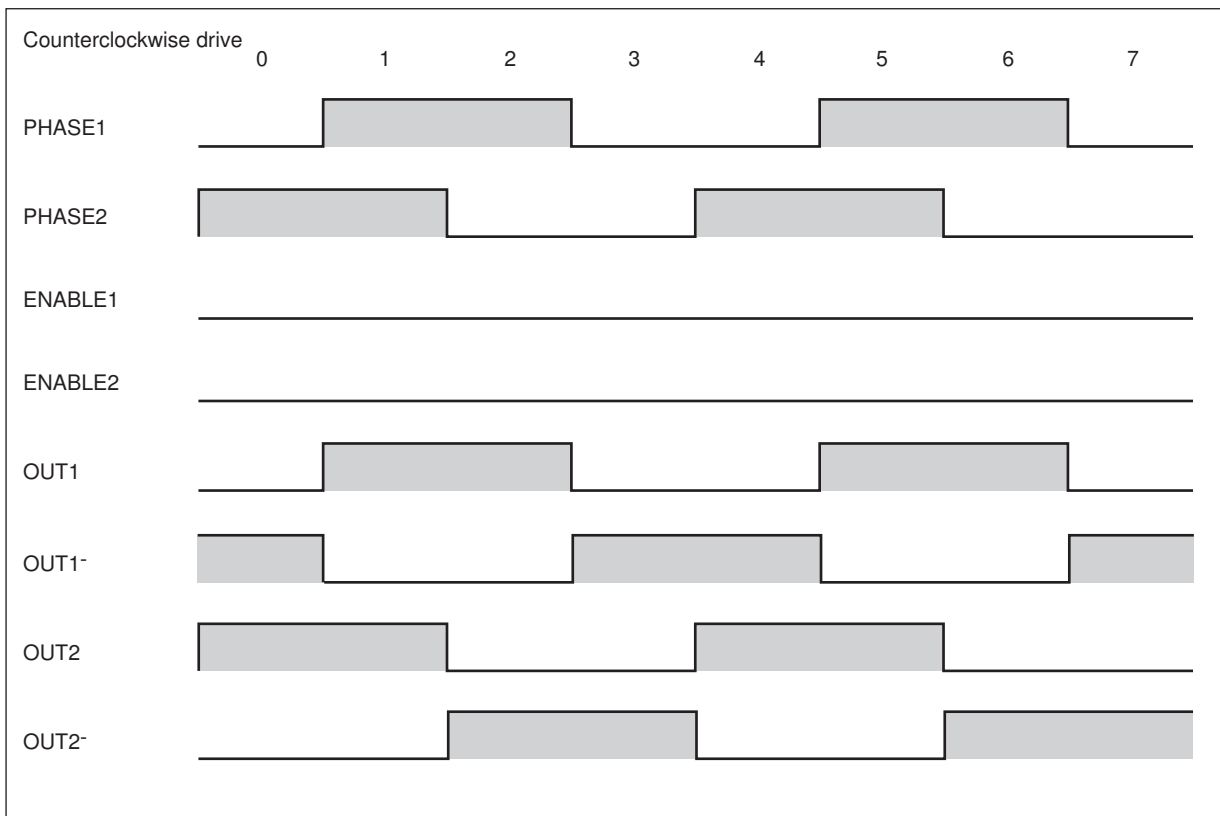
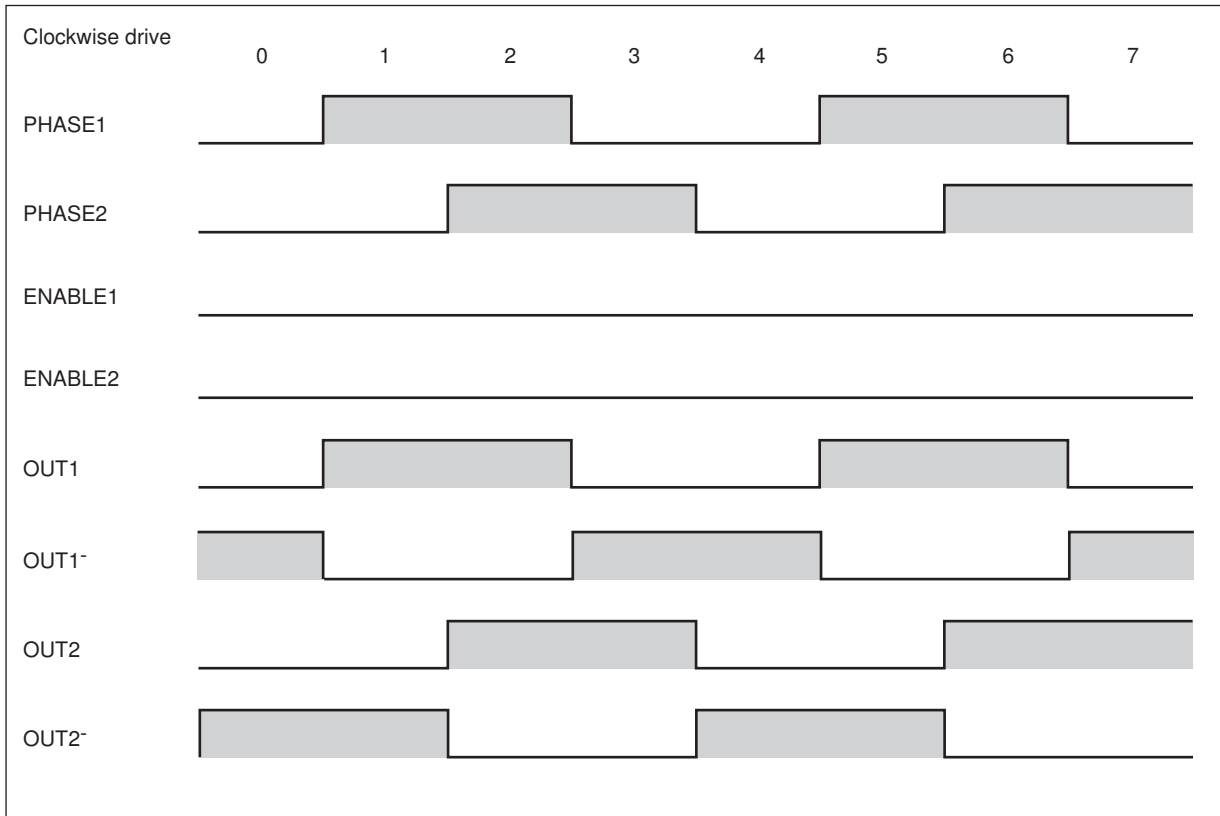

# LB11948T

## 1-2 Phase Excitation Drive Sequence

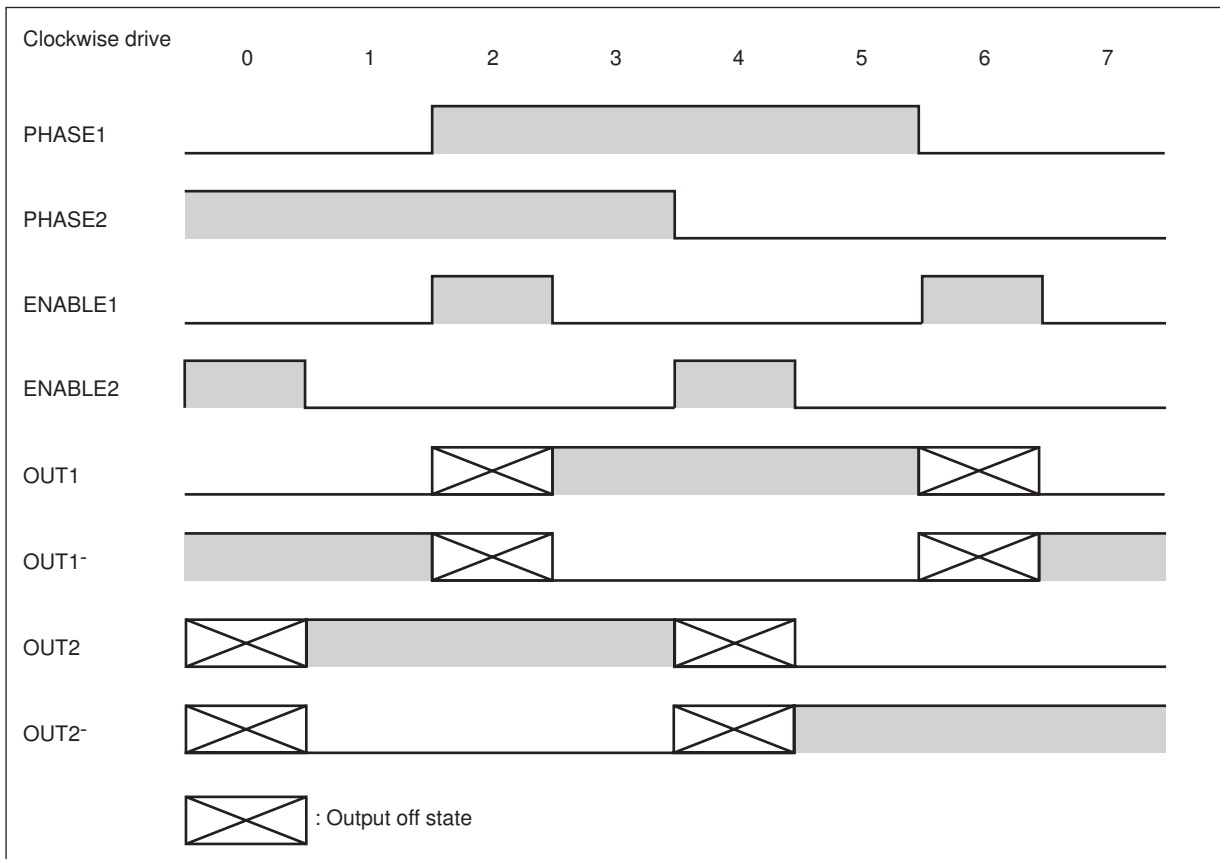
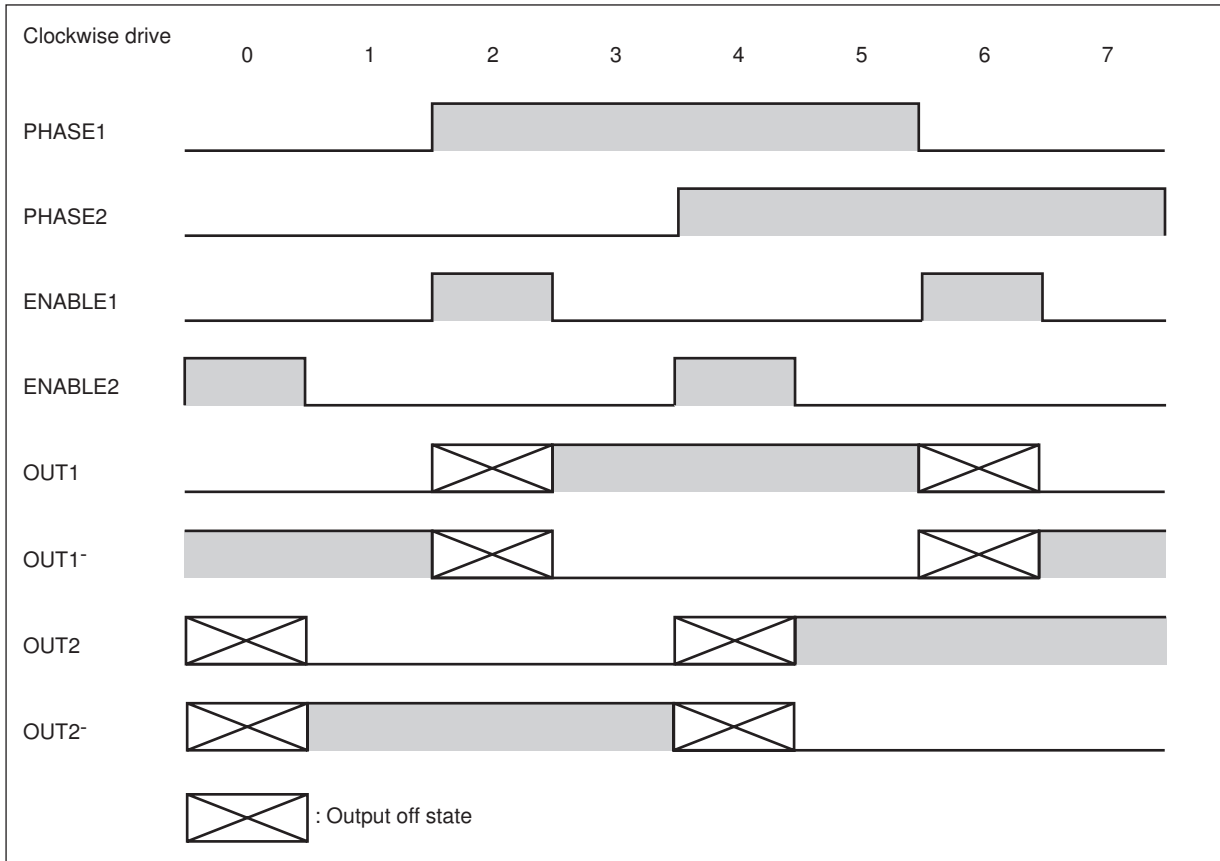

Switching Operation Timing Chart

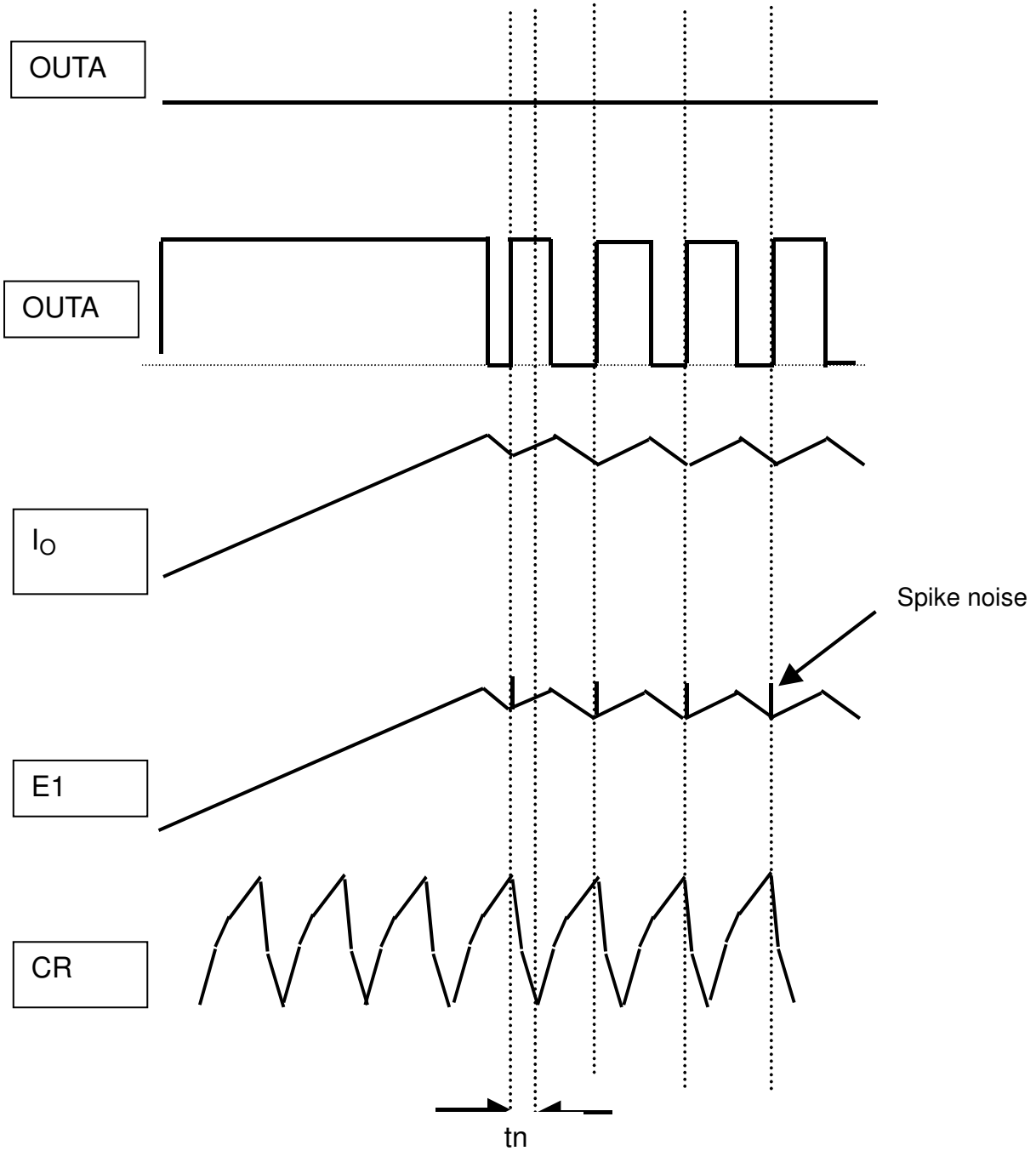

tn: The noise canceller operating time

**Usage Notes**

(1) Simple Formulas for Determining Resistor and Capacitor Values

The formula for setting the rising time (T1) and the falling time (T2) for the RC oscillator are shown below. (Refer to Fig. 1)

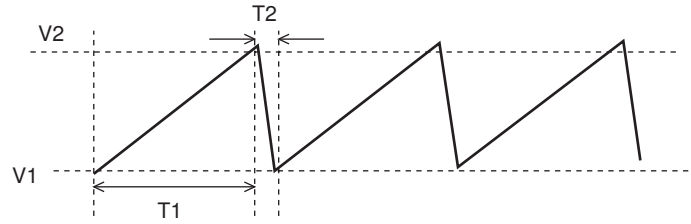

Fig. 1

Formulas

Oscillation period  $T = T1 + T2$  (sec)

Threshold voltages  $V1 = ((V_{CC} - V_{set1}) \times 10.7k / 48.7k) + V_{set1}$  (V)

$V2 = ((V_{CC} - V_{set2}) \times 42.7k / 80.7k) + V_{set2}$  (V)

$V_{set1}$  : VCE voltage of transistor for internal comparator hysteresis = 0.05V

$V_{set2}$  : VCE voltage of reference resistance switching transistor of oscillation circuit = 0.1V

When charging :  $T1 = -C \times R \times \ln \{ (V_{CC} - V2) / (V_{CC} - V1) \}$  (sec)

When discharging :  $T2 = -C \times R_{in} \times \ln (V1 / V2)$  (sec)

$R_{in}$  : Internal discharge resistance of the CR pin 1.3kΩ

C : External capacitor

R : External resistor

Oscillation frequency  $F_c = 1/T$  (Hz)

The T2 fall time serves as the noise canceling time (Tn). This time is a forced-on time for the output, and the output is not turned off even when the E pin voltage is higher than the sense voltage that has been preset by VREF.

## (2) Constant current settings

The reference voltages of the VREF1 and VREF2 pins can be set by dividing the resistance voltage from the 1V regulator output pin (1VREG).

The output current is set using the VREF reference voltage applied to the VREF1 and VREF2 pins and the Re resistor connected between the E1 and E2 pins and ground. The bias current of the output transistor also flows from the E pins so that the Iout output current flowing to the motor is reduced by an amount equivalent to the bias current. In addition, in controlling the constant current, the voltage is sensed by the E pins (pad area on IC chip) so that the amount equivalent to the wire bonding resistance (rw) from the pad to the package pins is added to the current sensing resistance (Re).

Therefore, the formula for calculating the current setting is as shown below. (Refer to Fig. 2)

$$I_{OUT} = VREF / (Re + rw) - I_{bias} \quad [A]$$

Re : Sensing resistance of resistor connected between E pins and ground

rw : Amount equivalent to wire bonding resistance from pad to pins  $rw = 50 - 100m\Omega$

Ibias : Output transistor bias current

The Ibias current corresponds to the current setting reactive current (IE) in the specifications for the electrical characteristics.

Current setting reactive current IE ratings : Min : -22mA Typ : -17mA Max : -10.5mA

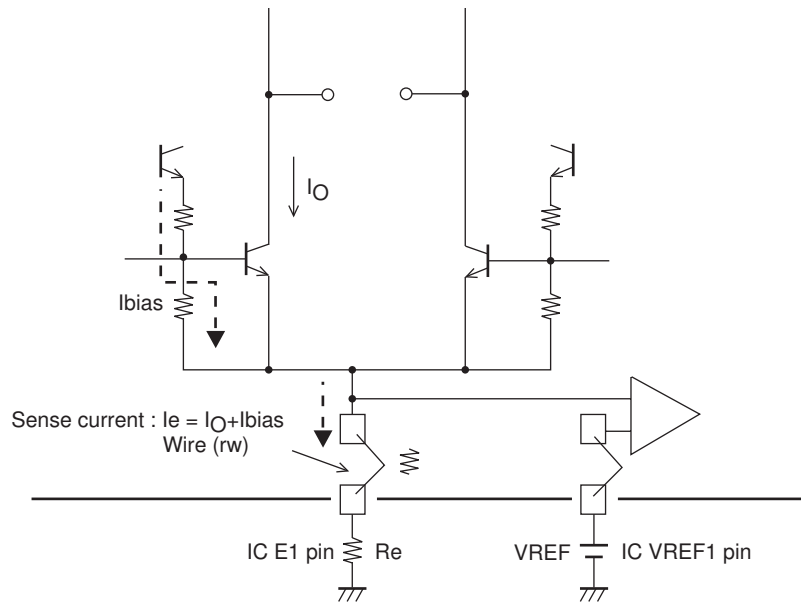

Fig. 2

## (3) VREF pins

The VREF pins are the reference voltage input pins for the preset current, so take special care to ensure that they are not affected by noise. If these pins will be affected by noise, connect a capacitor to VREF1 and VREF2 pins.

## (4) Notes on the Ground Pins

Since this IC switches large currents, the following notes on ground lines must be observed.

- The PCB pattern lines in areas that handle large currents must be as wide as possible so as to have low impedances, and must be kept as far as possible from the small signal systems.
- The ground terminals on the sensing resistors Re connected to the E pins (E1 and E2) must be connected as close as possible to the IC GND (pin 21), PGND (pin 22), or DGND (pins 5 and 26) pins as possible.
- The capacitors between VCC and ground and between VBB and ground must be as close as possible to the corresponding VCC and VBB pin in the pattern.

ON Semiconductor and the ON logo are registered trademarks of Semiconductor Components Industries, LLC (SCILLC). SCILLC owns the rights to a number of patents, trademarks, copyrights, trade secrets, and other intellectual property. A listing of SCILLC's product/patent coverage may be accessed at [www.onsemi.com/site/pdf/Patent-Marking.pdf](http://www.onsemi.com/site/pdf/Patent-Marking.pdf). SCILLC reserves the right to make changes without further notice to any products herein. SCILLC makes no warranty, representation or guarantee regarding the suitability of its products for any particular purpose, nor does SCILLC assume any liability arising out of the application or use of any product or circuit, and specifically disclaims any and all liability, including without limitation special, consequential or incidental damages. "Typical" parameters which may be provided in SCILLC data sheets and/or specifications can and do vary in different applications and actual performance may vary over time. All operating parameters, including "Typicals" must be validated for each customer application by customer's technical experts. SCILLC does not convey any license under its patent rights nor the rights of others. SCILLC products are not designed, intended, or authorized for use as components in systems intended for surgical implant into the body, or other applications intended to support or sustain life, or for any other application in which the failure of the SCILLC product could create a situation where personal injury or death may occur. Should Buyer purchase or use SCILLC products for any such unintended or unauthorized application, Buyer shall indemnify and hold SCILLC and its officers, employees, subsidiaries, affiliates, and distributors harmless against all claims, costs, damages, and expenses, and reasonable attorney fees arising out of, directly or indirectly, any claim of personal injury or death associated with such unintended or unauthorized use, even if such claim alleges that SCILLC was negligent regarding the design or manufacture of the part. SCILLC is an Equal Opportunity/Affirmative Action Employer. This literature is subject to all applicable copyright laws and is not for resale in any manner.