



ON Semiconductor®

<http://onsemi.com>

LB11946

Monolithic Digital IC PWM Current Control Stepping Motor Driver

Overview

The LB11946 is a stepping motor driver IC that implements PWM current control bipolar drive with a fixed off time. This IC features 15 current setting levels using a fixed VREF voltage and support for micro-stepping drive from 1-2 phase excitation drive to 4W1-2 phase excitation drive. This device is optimal for driving stepping motors such as those used for carriage drive and paper feed in printers.

Features

- PWM current control (with a fixed off time)
- Logic input serial-parallel converter (allows 1-2, W1-2, 2W1-2, and 4W1-2 phase excitation drive)
- Current attenuation switching function (with slow decay, fast decay, and mixed decay modes)
- Built-in upper and lower side diodes
- Simultaneous on state prevention function (through current prevention)
- Noise canceller function
- Thermal shutdown circuit
- Shutoff on low logic system voltage circuit
- Low-power mode control pin

Specifications

Maximum Ratings at Ta = 25°C

Parameter	Symbol	Conditions	Ratings	Unit
Motor supply voltage	V _{BB}		50	V
Peak output current	I _{O peak}	tw ≤ 20μS	1.2	A
Continuous output current	I _{O max}		1.0	A
Logic system supply voltage	V _{CC}		7.0	V
Logic input voltage range	V _{IN}		-0.3 to V _{CC}	V
Emitter output voltage	V _E	V _{CC} = 5V specifications	1.0	V
		V _{CC} = 3.3V specifications	0.5	V
Allowable power dissipation	P _{d max}	Independent IC	3.0	W
Operating temperature	T _{opr}		-25 to +85	°C
Storage temperature	T _{stg}		-55 to +150	°C

Stresses exceeding Maximum Ratings may damage the device. Maximum Ratings are stress ratings only. Functional operation above the Recommended Operating Conditions is not implied. Extended exposure to stresses above the Recommended Operating Conditions may affect device reliability.

LB11946

Recommended Operating Conditions at Ta = 25°C

Parameter	Symbol	Conditions	Ratings	Unit
Motor supply voltage	V _{BB}		10 to 45	V
Logic system supply voltage	V _{CC}	V _{CC} = 5V specifications	4.5 to 5.5	V
		V _{CC} = 3.3V specifications	3.0 to 3.6	V
Reference voltage	V _{REF}	V _{CC} = 5V specifications	0.0 to 3.0	V
		V _{CC} = 3.3V specifications	0.0 to 1.0	V

Electrical Characteristics at Ta = 25°C, V_{CC} = 5V, V_{BB} = 42V, V_{REF} = 1.52V

Parameter	Symbol	Conditions	Ratings			Unit
			min	typ	max	
Output Block						
Output stage supply current	I _{BB ON}		0.9	1.3	1.7	mA
	I _{BB OFF}		0.52	0.7	1.05	mA
Output saturation voltage	V _{O(sat) 1}	I _O = +0.5A (sink)		1.1	1.4	V
	V _{O(sat) 2}	I _O = +1.0A (sink)		1.4	1.7	V
	V _{O(sat) 3}	I _O = -0.5A (source)		1.9	2.2	V
	V _{O(sat) 4}	I _O = -1.0A (source)		2.2	2.5	V
Output leakage current	I _{O1} (leak)	V _O = V _{BB} (sink)			50	μA
	I _{O2} (leak)	V _O = 0V (source)	-50			μA
Output sustain voltage	V _{SUS}	L = 15mH, I _O = 1.0A, Design guarantee *	45			V
Logic Block						
Logic system supply current	I _{CC ON}	D0 = 1, D1 = 1, D2 = 1, D3 = 1 When these data values are set	24	35	46	mA
	I _{CC OFF1}	D0 = 0, D1 = 0, D2 = 0, D3 = 0	22	32	42	mA
	I _{CC OFF2}	ST = LOW		0.05	0.1	mA
Input voltage	V _{IH}		2			V
	V _{IL}				0.8	V
Input current	I _{IH}	V _{IH} = 2 V			35	μA
	I _{IL}	V _{IL} = 0.8 V	6			μA
Sense voltages	V _E	D0 = 1, D1 = 1, D2 = 1, D3 = 1 When these data values are set	0.470	0.50	0.525	V
		D0 = 1, D1 = 1, D2 = 1, D3 = 0	0.445	0.48	0.505	V
		D0 = 1, D1 = 1, D2 = 0, D3 = 1	0.425	0.46	0.485	V
		D0 = 1, D1 = 1, D2 = 0, D3 = 0	0.410	0.43	0.465	V
		D0 = 1, D1 = 0, D2 = 1, D3 = 1	0.385	0.41	0.435	V
		D0 = 1, D1 = 0, D2 = 1, D3 = 0	0.365	0.39	0.415	V
		D0 = 1, D1 = 0, D2 = 0, D3 = 1	0.345	0.37	0.385	V
		D0 = 1, D1 = 0, D2 = 0, D3 = 0	0.325	0.35	0.365	V
		D0 = 0, D1 = 1, D2 = 1, D3 = 1	0.280	0.30	0.325	V
		D0 = 0, D1 = 1, D2 = 1, D3 = 0	0.240	0.26	0.285	V
		D0 = 0, D1 = 1, D2 = 0, D3 = 1	0.195	0.22	0.235	V
		D0 = 0, D1 = 1, D2 = 0, D3 = 0	0.155	0.17	0.190	V
		D0 = 0, D1 = 0, D2 = 1, D3 = 1	0.115	0.13	0.145	V
		D0 = 0, D1 = 0, D2 = 1, D3 = 0	0.075	0.09	0.100	V
Reference current	I _{REF}	V _{REF} = 1.5V	-0.5			μA
CR pin current	I _{CR}	CR = 1.0V	-1.6	-1.2	-0.8	mA
MD pin current	I _{MD}	MD = 1.0V, CR = 4.0V	-5.0			μA
Logic system on voltage	V _{LSDON}		2.6	2.8	3.0	V
Logic system off voltage	V _{LSDOFF}		2.45	2.65	2.85	V
LVSD hysteresis	V _{LHIS}		0.03	0.15	0.35	V
Thermal shutdown temperature	T _s	Design guarantee *		170		°C

*Design guarantee: Design guarantee value, Do not measurement.

LB11946

AC Electrical Characteristics at $V_{CC} = 5V$

Parameter	Symbol	Conditions	Ratings			Unit
			min	typ	max	
Clock frequency	Fclk			200	550	kHz
Data setup time	TDS		0.9	2.5		μS
Data hold time	TDH		0.9	2.5		μS
Minimum clock high-level pulse width	TSCH		0.9	2.5		μS
Minimum clock low-level pulse width	TSCL		0.9	2.5		μS
SET pin stipulated time	Tlat		0.9	2.5		μS
SET pin signal pulse width	Tlatw		1.9	5.0		μS

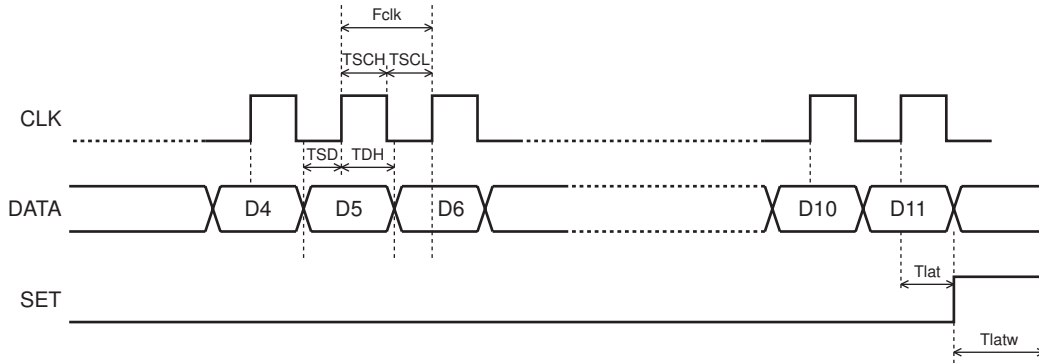

LB11946

Electrical Characteristics at $T_a = 25^\circ\text{C}$, $V_{CC} = 3.3\text{V}$, $V_{BB} = 42\text{V}$, $V_{REF} = 1.0\text{V}$

(When measuring the sense voltage: $V_{REF} = 1.03\text{V}$)

Parameter	Symbol	Conditions	Ratings			Unit
			min	typ	max	
Output Block						
Output stage supply current	$I_{BB\ ON}$		0.9	1.3	1.7	mA
	$I_{BB\ OFF}$		0.52	0.7	1.05	mA
Output saturation voltage	$V_{O(sat)\ 1}$	$I_O = +0.5\text{A}$ (sink)		1.2	1.5	V
	$V_{O(sat)\ 2}$	$I_O = +1.0\text{A}$ (sink)		1.5	1.8	V
	$V_{O(sat)\ 3}$	$I_O = -0.5\text{A}$ (source)		2.0	2.3	V
	$V_{O(sat)\ 4}$	$I_O = -1.0\text{A}$ (source)		2.3	2.6	V
Output leakage current	I_{O1} (leak)	$V_O = V_{BB}$ (sink)			50	μA
	I_{O2} (leak)	$V_O = 0\text{V}$ (source)	-50			μA
Output sustain voltage	V_{SUS}	$L = 15\text{mH}$ $I_O = 1.5\text{A}$, Design guarantee *	45			V
Logic Block						
Logic system supply current	$I_{CC\ ON}$	$D0 = 1, D1 = 1, D2 = 1, D3 = 1$ When these data values are set	21	30	39	mA
	$I_{CC\ OFF1}$	$D0 = 0, D1 = 0, D2 = 0, D3 = 0$	19	28	36.5	mA
	$I_{CC\ OFF2}$	$ST = 0.8\text{V}$		0.03	0.1	mA
Input voltage	V_{IH}		2			V
	V_{IL}				0.8	V
Input current	I_{IH}	$V_{IH} = 2\text{V}$			35	μA
	I_{IL}	$V_{IL} = 0.8\text{V}$	6			μA
Sense voltages	VE	$D0 = 1, D1 = 1, D2 = 1, D3 = 1$ $V_{REF} = 1.03\text{V}$	0.303	0.330	0.356	V
		$D0 = 1, D1 = 1, D2 = 1, D3 = 0$ $V_{REF} = 1.03\text{V}$	0.290	0.315	0.341	V
		$D0 = 1, D1 = 1, D2 = 0, D3 = 1$ $V_{REF} = 1.03\text{V}$	0.276	0.300	0.324	V
		$D0 = 1, D1 = 1, D2 = 0, D3 = 0$ $V_{REF} = 1.03\text{V}$	0.263	0.286	0.309	V
		$D0 = 1, D1 = 0, D2 = 1, D3 = 1$ $V_{REF} = 1.03\text{V}$	0.250	0.272	0.294	V
		$D0 = 1, D1 = 0, D2 = 1, D3 = 0$ $V_{REF} = 1.03\text{V}$	0.236	0.257	0.278	V
		$D0 = 1, D1 = 0, D2 = 0, D3 = 1$ $V_{REF} = 1.03\text{V}$	0.223	0.243	0.263	V
		$D0 = 1, D1 = 0, D2 = 0, D3 = 0$ $V_{REF} = 1.03\text{V}$	0.209	0.228	0.247	V
		$D0 = 0, D1 = 1, D2 = 1, D3 = 1$ $V_{REF} = 1.03\text{V}$	0.183	0.200	0.217	V
		$D0 = 0, D1 = 1, D2 = 1, D3 = 0$ $V_{REF} = 1.03\text{V}$	0.155	0.170	0.185	V
		$D0 = 0, D1 = 1, D2 = 0, D3 = 1$ $V_{REF} = 1.03\text{V}$	0.128	0.143	0.158	V
		$D0 = 0, D1 = 1, D2 = 0, D3 = 0$ $V_{REF} = 1.03\text{V}$	0.102	0.114	0.126	V
		$D0 = 0, D1 = 0, D2 = 1, D3 = 1$ $V_{REF} = 1.03\text{V}$	0.074	0.085	0.096	V
		$D0 = 0, D1 = 0, D2 = 1, D3 = 0$ $V_{REF} = 1.03\text{V}$	0.047	0.057	0.067	V
Reference current	I_{REF}	$V_{REF} = 1.0\text{V}$	-0.5			μA
CR pin current	I_{CR}	$CR = 1.0\text{V}$	-0.91	-0.7	-0.49	mA
MD pin current	I_{MD}	$MD = 1.0\text{V}$, $CR = 4.0\text{V}$	-5.0			μA
LVSD voltage	V_{LSDON}		2.6	2.8	3.0	V
Logic system off voltage	V_{LSDOFF}		2.45	2.65	2.85	V
LVSD hysteresis	V_{LHIS}		0.03	0.15	0.35	V
Thermal shutdown temperature	T_s	Design guarantee *		170		$^\circ\text{C}$

*Design guarantee: Design guarantee value, Do not measurement.

LB11946

AC Electrical Characteristics at $V_{CC} = 3.3V$

Parameter	Symbol	Conditions	Ratings			Unit
			min	typ	max	
Clock frequency	Fclk			200	550	kHz
Data setup time	TDS		0.9	2.5		μS
Data hold time	TDH		0.9	2.5		μS
Minimum clock high-level pulse width	TSCH		0.9	2.5		μS
Minimum clock low-level pulse width	TSCL		0.9	2.5		μS
SET pin stipulated time	Tlat		0.9	2.5		μS
SET pin signal pulse width	Tlatw		1.9	5.0		μS

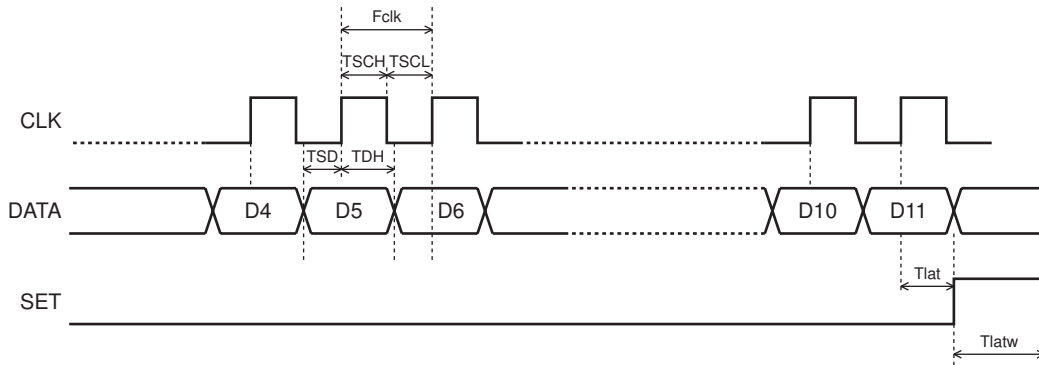

LB11946

Package Dimensions

unit : mm (typ)
3147C

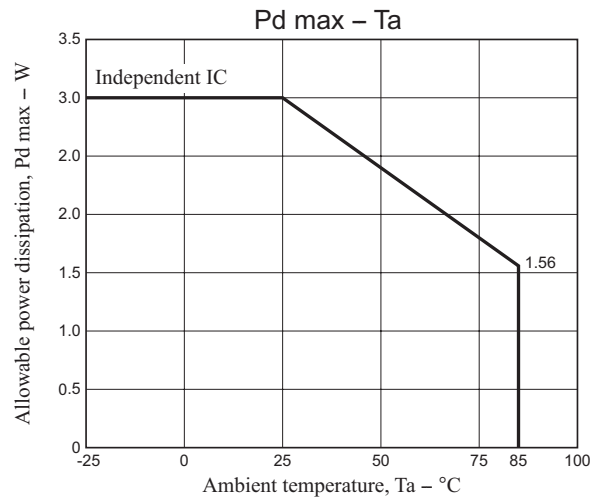
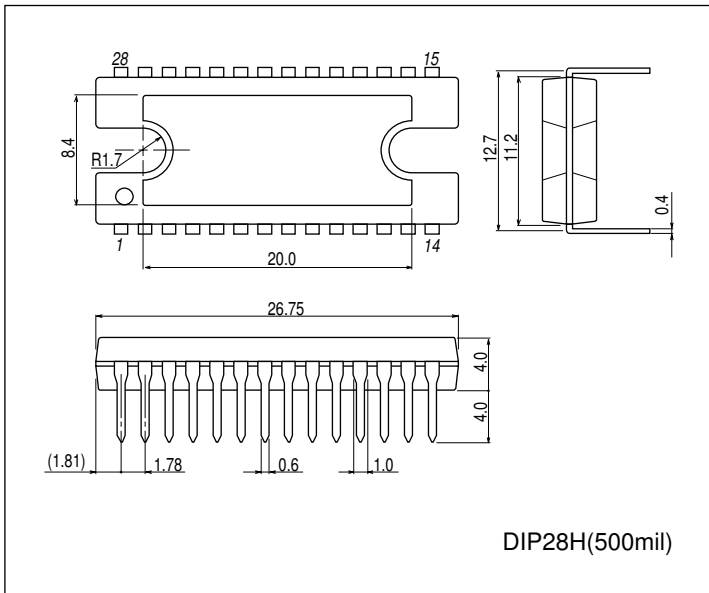

Pin Assignment

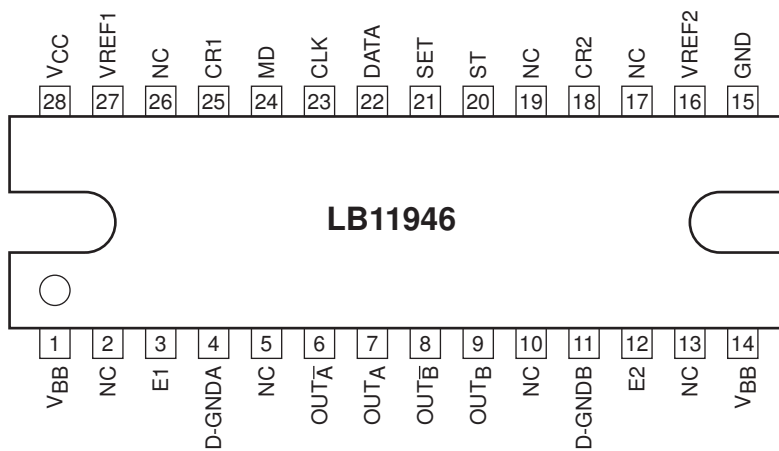

Note: The D-GNDA and D-GNDB pins are the anode sides of the lower side diodes

Timing Chart

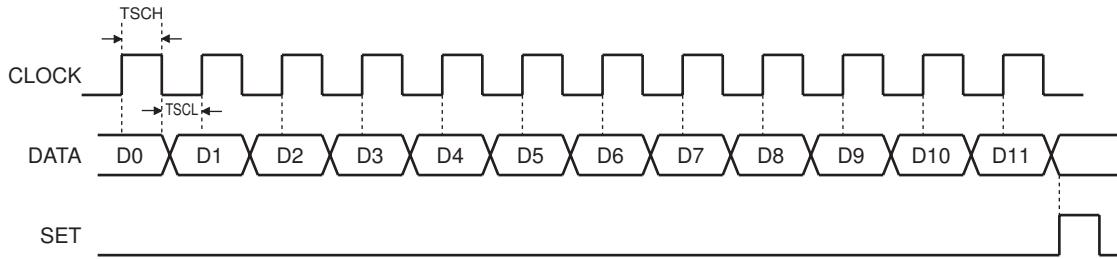

Serially Transferred Data Definition

No.	IA4	IA3	IA2	IA1	DE1	PH1	IB4	IB3	IB2	IB1	DE2	PH2	Output mode				I/O ratio	DEC MODE
	D0	D1	D2	D3	D4	D5	D6	D7	D8	D9	D10	D11	OUT _A	OUT _A [̄]	OUT _B	OUT _B [̄]		
0	1	1	1	1	1	1	1	1	1	1	1	1	H	L	H	L	100%	SLOW
1	1	1	1	0	1	1	1	1	1	0	1	1	H	L	H	L	96	SLOW
2	1	1	0	1	1	1	1	1	0	1	1	1	H	L	H	L	91	SLOW
3	1	1	0	0	1	1	1	1	0	0	1	1	H	L	H	L	87	SLOW
4	1	0	1	1	1	1	1	0	1	1	1	1	H	L	H	L	83	SLOW
5	1	0	1	0	1	1	1	0	1	0	1	1	H	L	H	L	78	SLOW
6	1	0	0	1	1	1	1	0	0	1	1	1	H	L	H	L	74	SLOW
7	1	0	0	0	1	1	1	0	0	0	1	1	H	L	H	L	70	SLOW
8	0	1	1	1	1	1	0	1	1	1	1	1	H	L	H	L	61	SLOW
9	0	1	1	0	1	1	0	1	1	0	1	1	H	L	H	L	52	SLOW
10	0	1	0	1	1	1	0	1	0	1	1	1	H	L	H	L	44	SLOW
11	0	1	0	0	1	1	0	1	0	0	1	1	H	L	H	L	35	SLOW
12	0	0	1	1	1	1	0	0	1	1	1	1	H	L	H	L	26	SLOW
13	0	0	1	0	1	1	0	0	1	0	1	1	H	L	H	L	17	SLOW
14	1	1	1	1	0	0	1	1	1	1	0	0	L	H	L	H	100	FAST
15	1	1	1	0	0	0	1	1	1	0	0	0	L	H	L	H	96	FAST
16	1	1	0	1	0	0	1	1	0	1	0	0	L	H	L	H	91	FAST
17	1	1	0	0	0	0	1	1	0	0	0	0	L	H	L	H	87	FAST
18	1	0	1	1	0	0	1	0	1	1	0	0	L	H	L	H	83	FAST
19	1	0	1	0	0	0	1	0	1	0	0	0	L	H	L	H	78	FAST
20	1	0	0	1	0	0	1	0	0	1	0	0	L	H	L	H	74	FAST
21	1	0	0	0	0	0	1	0	0	0	0	0	L	H	L	H	70	FAST
22	0	1	1	1	0	0	0	1	1	1	0	0	L	H	L	H	61	FAST
23	0	1	1	0	0	0	0	1	1	0	0	0	L	H	L	H	52	FAST
24	0	1	0	1	0	0	0	1	0	1	0	0	L	H	L	H	44	FAST
25	0	1	0	0	0	0	0	1	0	0	0	0	L	H	L	H	35	FAST
26	0	0	1	1	0	0	0	0	1	1	0	0	L	H	L	H	26	FAST
27	0	0	1	0	0	0	0	0	1	0	0	0	L	H	L	H	17	FAST
28	0	0	0	0	*	*	0	0	0	0	*	*	OFF	OFF	OFF	OFF	0	-

Note *: Either 0 or 1.

Note *1: In mixed decay mode, set D4 and D10 to 0 and set the MD pin to a level in the range 1.5 to 4.0V.

LB11946

Current Settings Truth Table * Items in parentheses are defined by the serial data.

IA4 (D0)	IA3 (D1)	IA2 (D2)	IA1 (D3)	Set current Iout	Current ratio (%)
1	1	1	1	$11.5/11.5 \times VREF/3.04RE = Iout$	100
1	1	1	0	$11.0/11.5 \times VREF/3.04RE = Iout$	95.65
1	1	0	1	$10.5/11.5 \times VREF/3.04RE = Iout$	91.30
1	1	0	0	$10.0/11.5 \times VREF/3.04RE = Iout$	86.95
1	0	1	1	$9.5/11.5 \times VREF/3.04RE = Iout$	82.61
1	0	1	0	$9.0/11.5 \times VREF/3.04RE = Iout$	78.26
1	0	0	1	$8.5/11.5 \times VREF/3.04RE = Iout$	73.91
1	0	0	0	$8.0/11.5 \times VREF/3.04RE = Iout$	69.56
0	1	1	1	$7.0/11.5 \times VREF/3.04RE = Iout$	60.87
0	1	1	0	$6.0/11.5 \times VREF/3.04RE = Iout$	52.17
0	1	0	1	$5.0/11.5 \times VREF/3.04RE = Iout$	43.48
0	1	0	0	$4.0/11.5 \times VREF/3.04RE = Iout$	34.78
0	0	1	1	$3.0/11.5 \times VREF/3.04RE = Iout$	26.08
0	0	1	0	$2.0/11.5 \times VREF/3.04RE = Iout$	17.39

Note: The current ratios shown are calculated values.

Block Diagram

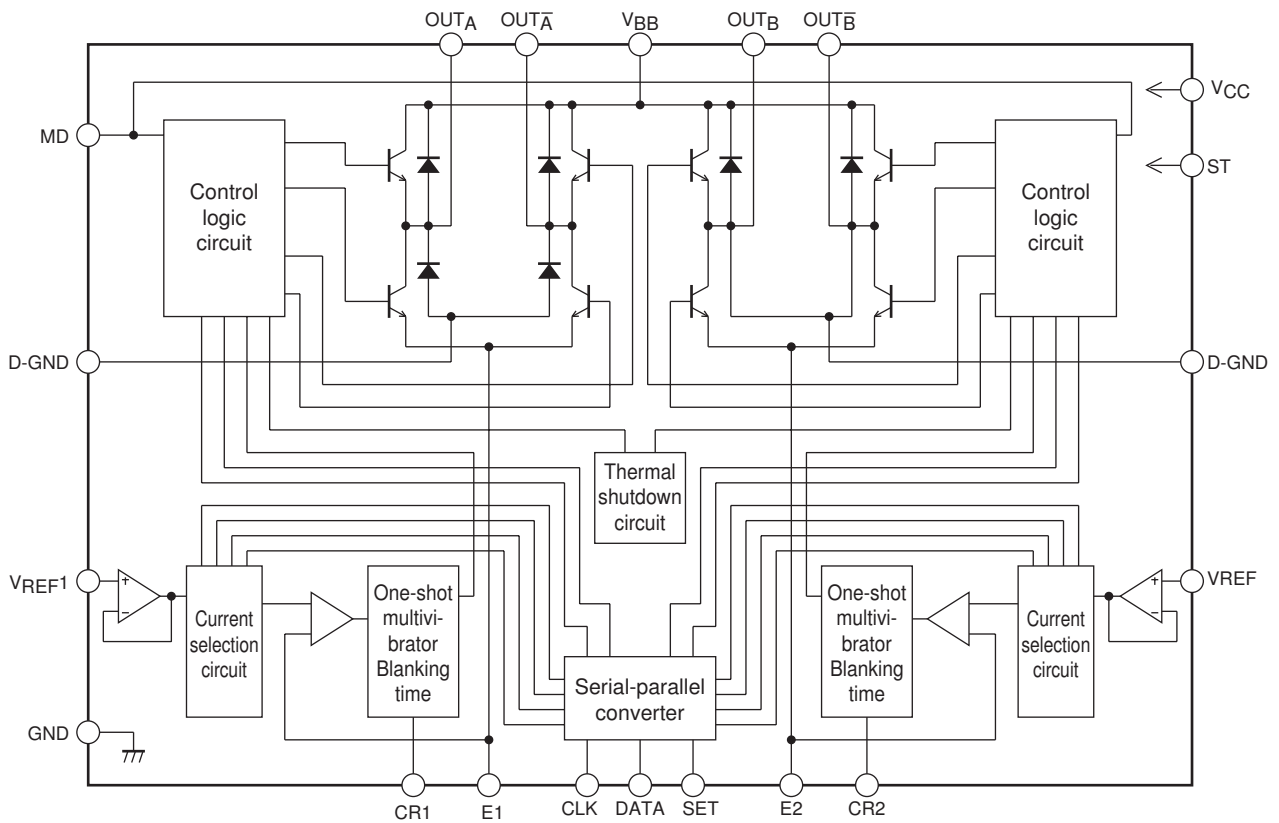

LB11946

Sample Application Circuit at $V_{CC} = 5V$

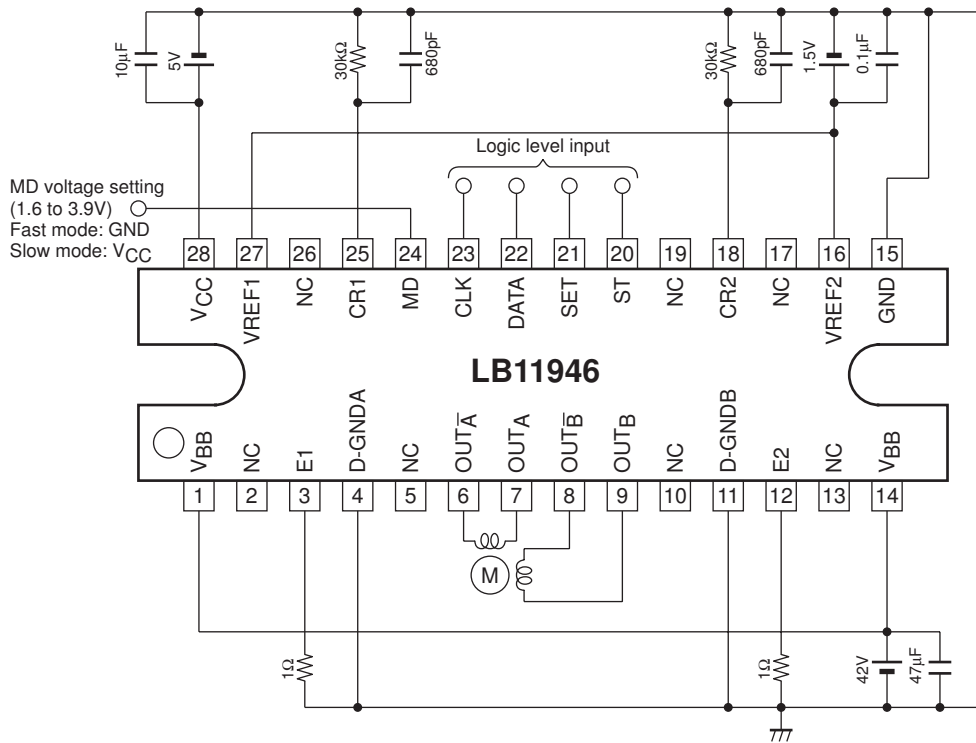

Sample Application Circuit at $V_{CC} = 3.3V$

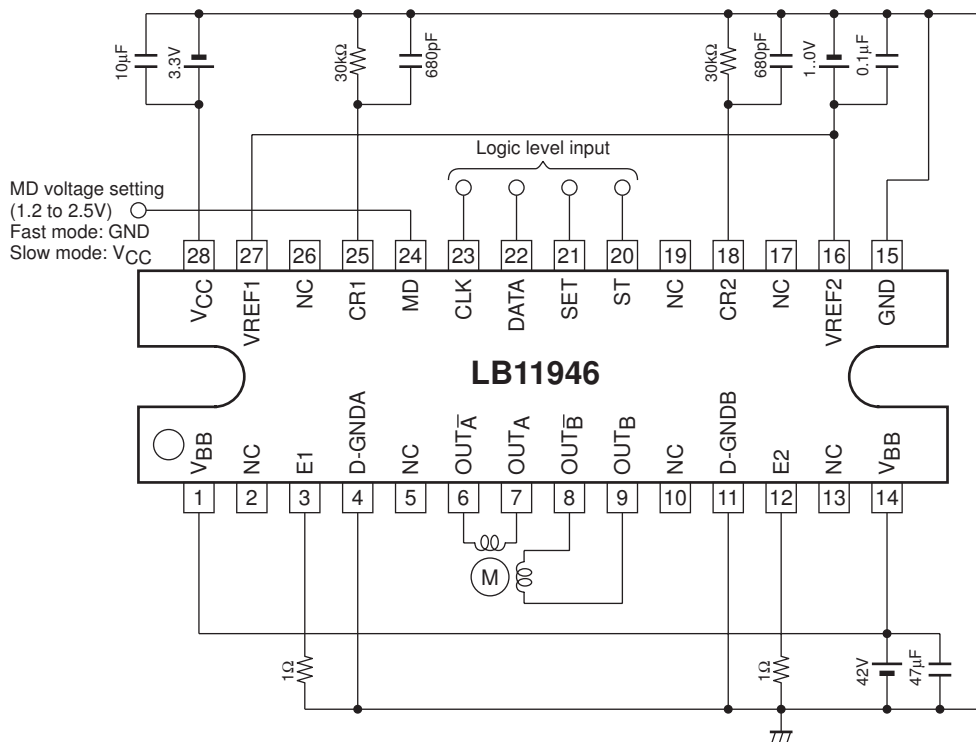

LB11946

SLOW DECAY Current Path

The reregenerative current at upper-side transistor switching operates

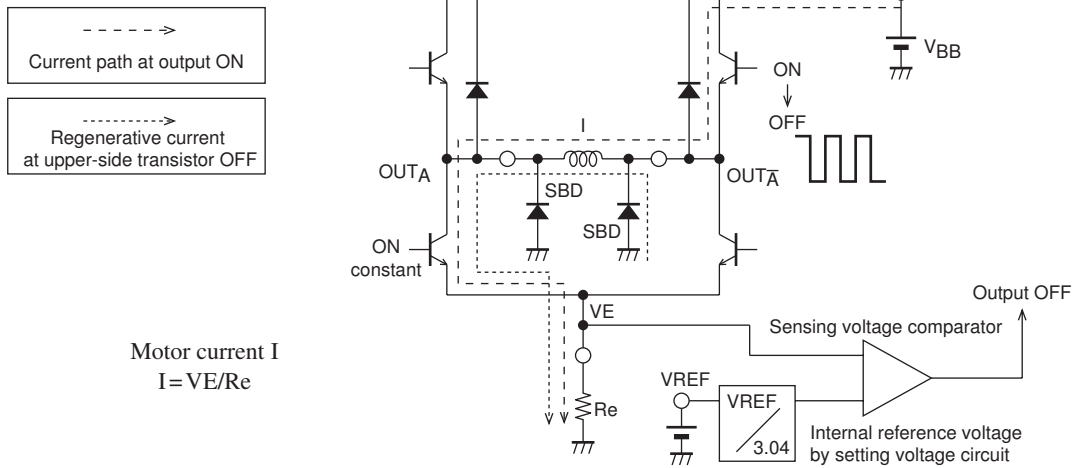

Fig.1

FAST DECAY Current Path

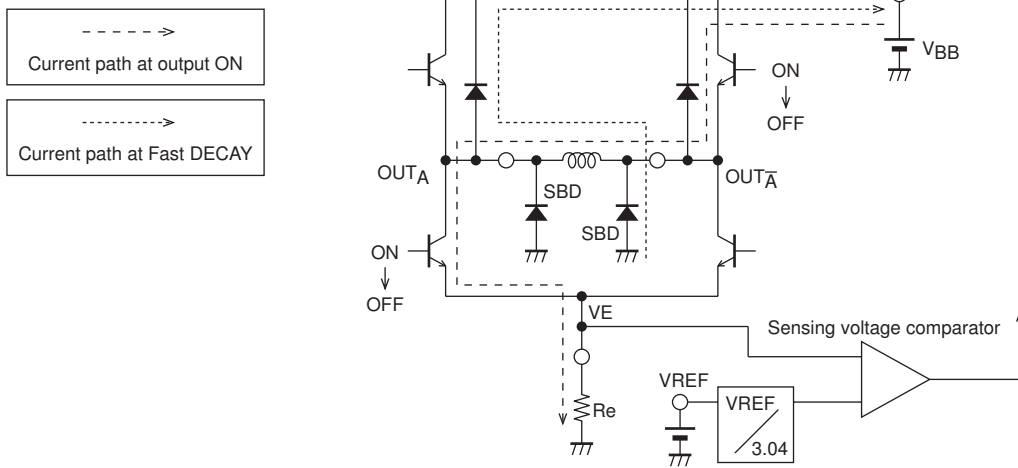

Fig.2

LB11946

Switching Time Chart at PWM operation

SLOW DECAY (Upper-side Chopping)

Serial transmission data (D4, D10) = High

MD pin: Low setting

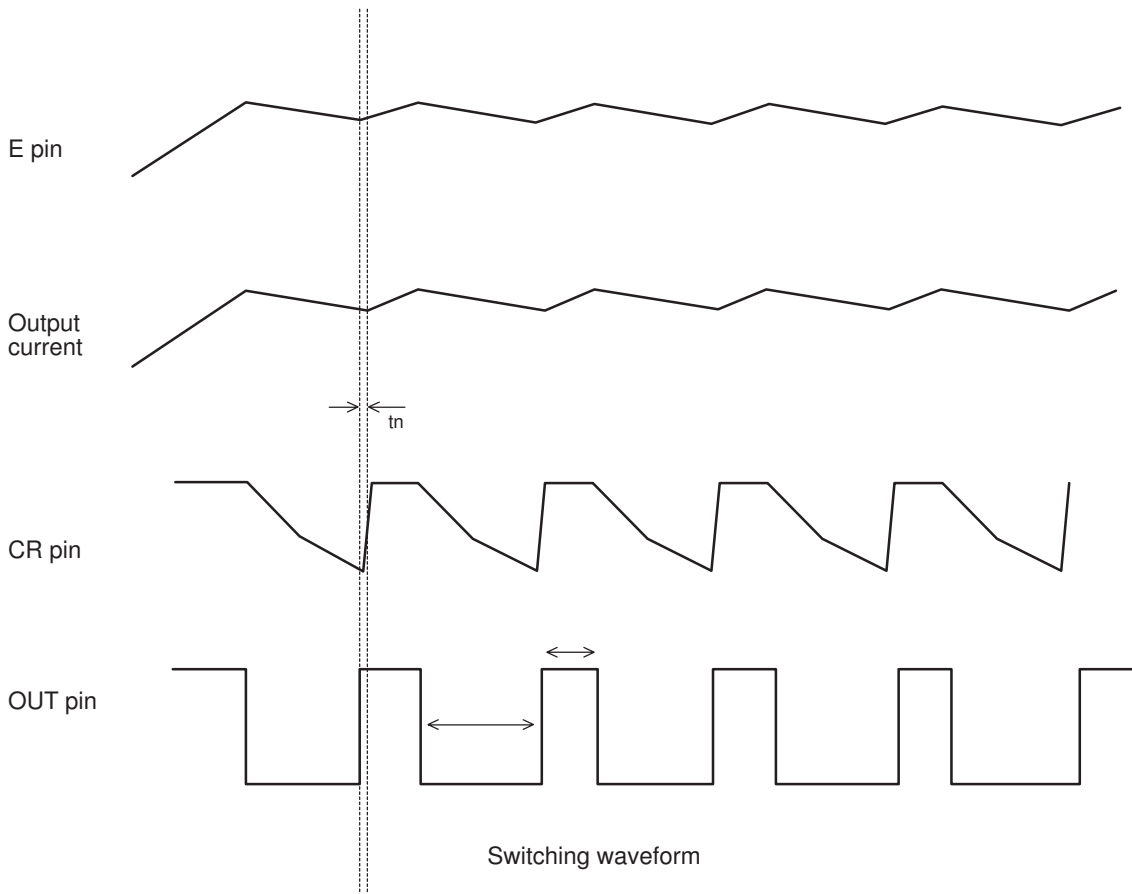

FAST DECAY

Serial transmission data (D4, D10) = Low

MD pin: Low setting

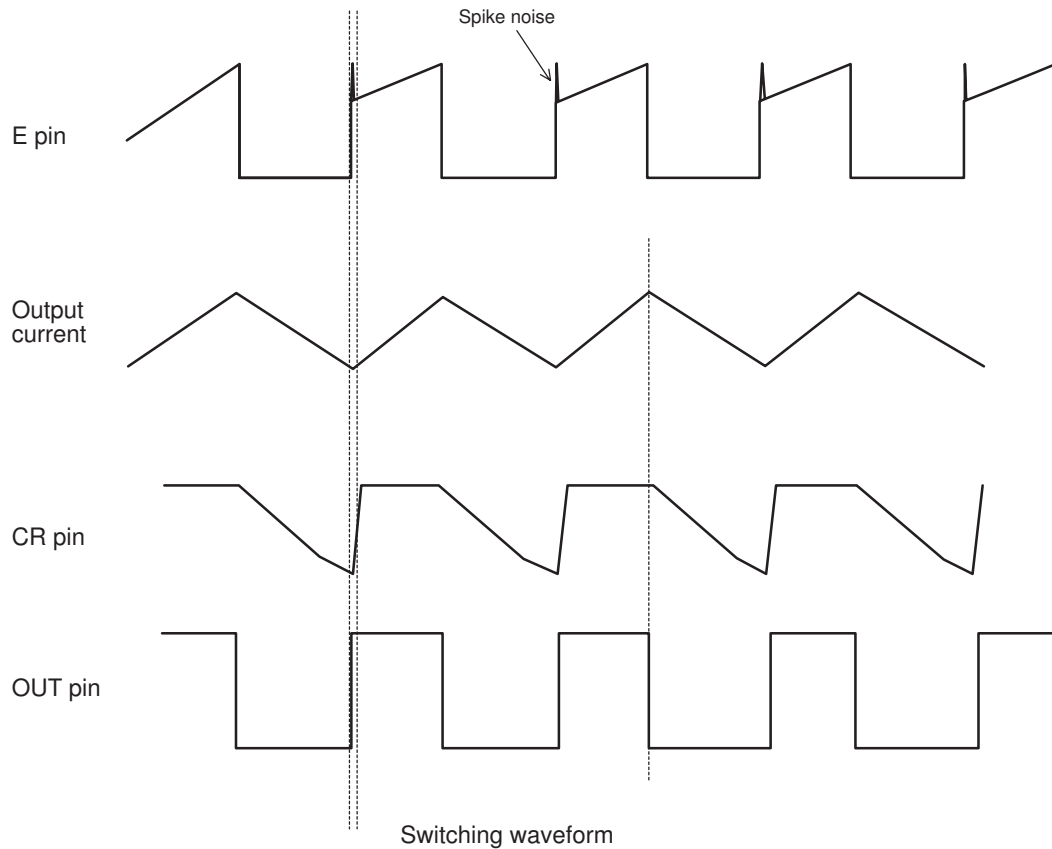

LB11946

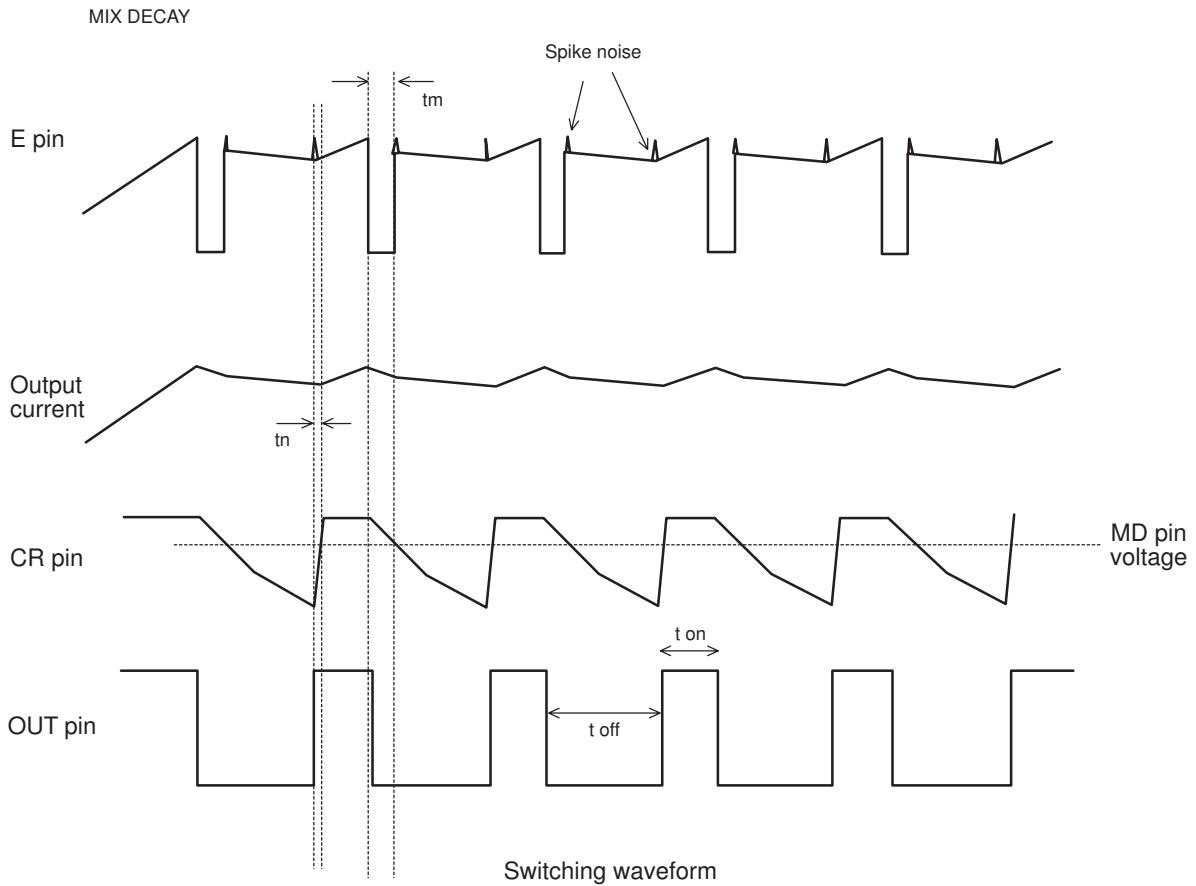

MIX DECAY logic setting

serial transmission data (D4, D10) = Low

MD pin: 1.6V to 3.0V at $V_{CC} = 5V$ specification.

1.2V to 2.5V at $V_{CC} = 3.3V$ specification.

t_{on} : Output ON time

t_{off} : Output OFF time

t_m : FAST DECAY time at MIX DECAY mode

t_n : Noise cancel time

The following operation by comparison between CR voltage and MD pin voltage in turning off time.

CR voltage > MD pin voltage: both sides chopping

CR voltage < MD pin voltage: upper side chopping

Attached Documents

1. Switching Off Time and Noise Canceller Time Calculations

Notes on the CR Pin Setting (switching off time and noise canceller time)

The noise canceller time (T_n) and the switching off time (T_{off}) are set using the following formulas.

(1) When V_{CC} is 5 V

Noise canceller time (T_n)

$$T_n \approx C \times R \times \ln \{ (1.5 - RI) / (4.0 - RI) \} [s]$$

CR pin charge current: 1.25mA

Switching off time (T_{off})

$$T_{off} \approx -C \times R \times \ln (1.5/4.8) [s]$$

Component value ranges

R: 5.6kΩ to 100kΩ

C: 470pF to 2000pF

(2) When V_{CC} is 3.3 V

Noise canceller time (T_n)

$$T_n \approx C \times R \times \ln \{ (1.06 - RI) / (2.66 - RI) \} [s]$$

CR pin charge current: 0.7 mA

Switching off time (T_{off})

$$T_{off} \approx -C \times R \times \ln (1.06 / 3.1) [s]$$

CR Pin Internal Circuit Structure

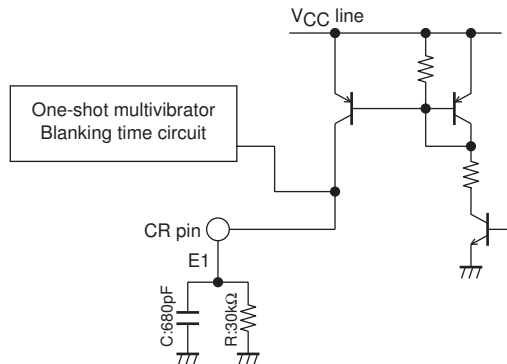

2. Notes on the MD Pin

(1) If slow decay mode is set up by setting the D4 and D10 bits in the input serial data to 1, the MD pin must be shorted to ground.

(2) If fast decay mode is set up by setting the D4 and D10 bits in the input serial data to 0, mixed decay mode can be set with the MD pin.

When the $V_{CC} = 5V$ specifications are used the setting voltage range for mixed decay mode is 1.6 to 3.9V.

When the $V_{CC} = 3.3V$ specifications are used the setting voltage range for mixed decay mode is 1.2 to 2.5V.

If mixed decay mode will not be used with the fast decay mode setting, either:

(a) Short the MD pin to ground to select fast decay mode, or

(b) Short the MD pin to V_{CC} to select slow decay mode.

Usage Notes

(1) Notes on the VREF pin

Since the VREF pin inputs the reference voltage used to set the current, applications must be designed so that noise does not occur at this pin.

(2) Notes on the ground pins

Since this IC switches large currents, care is required with respect to the ground pins.

The PCB pattern in sections where large currents flow must be designed with low impedances and must be kept separate from the small-signal system.

In particular, the ground terminals of the E1 and E2 pin sense resistors (R_e) and the external Schottky barrier diode ground terminals must be located as close as possible to the IC ground. The capacitors between V_{CC} and ground and between V_{BB} and ground must be as close as possible to the corresponding V_{CC} and V_{BB} pin in the pattern.

(3) Power on sequence

When turning the power systems on

$V_{CC} \rightarrow$ logic level inputs (CLK, DATA, SET, and ST) \rightarrow VREF \rightarrow V_{BB}

When turning the power systems off

$V_{BB} \rightarrow$ VREF logic level inputs (CLK, DATA, SET, and ST) \rightarrow V_{CC}

Note that if the power supply for the logic level inputs is on when the V_{CC} power supply is off, a bias with an unstable state will be applied due to the protection diodes at the V_{CC} pins, and this can cause incorrect operation.

ON Semiconductor and the ON logo are registered trademarks of Semiconductor Components Industries, LLC (SCILLC). SCILLC owns the rights to a number of patents, trademarks, copyrights, trade secrets, and other intellectual property. A listing of SCILLC's product/patent coverage may be accessed at www.onsemi.com/site/pdf/Patent-Marking.pdf. SCILLC reserves the right to make changes without further notice to any products herein. SCILLC makes no warranty, representation or guarantee regarding the suitability of its products for any particular purpose, nor does SCILLC assume any liability arising out of the application or use of any product or circuit, and specifically disclaims any and all liability, including without limitation special, consequential or incidental damages. "Typical" parameters which may be provided in SCILLC data sheets and/or specifications can and do vary in different applications and actual performance may vary over time. All operating parameters, including "Typicals" must be validated for each customer application by customer's technical experts. SCILLC does not convey any license under its patent rights nor the rights of others. SCILLC products are not designed, intended, or authorized for use as components in systems intended for surgical implant into the body, or other applications intended to support or sustain life, or for any other application in which the failure of the SCILLC product could create a situation where personal injury or death may occur. Should Buyer purchase or use SCILLC products for any such unintended or unauthorized application, Buyer shall indemnify and hold SCILLC and its officers, employees, subsidiaries, affiliates, and distributors harmless against all claims, costs, damages, and expenses, and reasonable attorney fees arising out of, directly or indirectly, any claim of personal injury or death associated with such unintended or unauthorized use, even if such claim alleges that SCILLC was negligent regarding the design or manufacture of the part. SCILLC is an Equal Opportunity/Affirmative Action Employer. This literature is subject to all applicable copyright laws and is not for resale in any manner.