



ON Semiconductor®

<http://onsemi.com>

LV8712T

Bi-CMOS LSI

PWM Constant-Current Control Stepping Motor Driver

Overview

The LV8712T is a stepping motor driver of the micro-step drive corresponding to supports 2W 1-2 phase excitation. It is the best for the drive of the stepping motor for a scanner and a small printer.

Features

- Single-channel PWM constant-current control stepping motor driver incorporated.
- Excitation mode can be set to 2-phase, 1-2 phase, W1-2 phase , or 2W1-2 phase
- Microstep can control easily by the CLK-IN input.
- Power-supply voltage of motor : VM max = 18V
- Output current : IO max = 0.8A
- Output ON resistance : RON = 1.1Ω (upper and lower total, typical, Ta = 25°C)
- A thermal shutdown circuit and a low voltage detecting circuit are built into.

Specifications

Absolute Maximum Ratings at Ta = 25°C

Parameter	Symbol	Conditions	Ratings	Unit
Motor supply voltage	VM max		18	V
Logic supply voltage	VCC max		6	V
Output peak current	IO peak	Each 1ch, tw ≤ 10ms, duty 20%	1.0	A
Output continuousness current	IO max	Each 1ch	800	mA
Logic input voltage	VIN		-0.3 to VCC + 0.3	V
Allowable power dissipation	Pd max	*	1.35	W
Operating temperature	Topr		-20 to +85	°C
Storage temperature	Tstg		-55 to +150	°C

* Specified circuit board : 57.0mm×57.0mm×1.7mm, glass epoxy 2-layer board.

Stresses exceeding Maximum Ratings may damage the device. Maximum Ratings are stress ratings only. Functional operation above the Recommended Operating Conditions is not implied. Extended exposure to stresses above the Recommended Operating Conditions may affect device reliability.

LV8712T

Allowable Operating Ratings at Ta = 25°C

Parameter	Symbol	Conditions	Ratings	Unit
Motor supply voltage range	VM		4 to 16	V
Logic supply voltage range	V _{CC}		2.7 to 5.5	V
Logic input voltage	V _{IN}		-0.3 to V _{CC} +0.3	V
VREF input voltage range	VREF		0 to V _{CC} -1.8	V

Electrical Characteristics at Ta = 25°C, VM = 12V, V_{CC} = 3.3V, VREF = 1.0V

Parameter	Symbol	Conditions	Ratings			Unit	
			min	typ	max		
Standby mode current drain	IMstn	PS = "L", no load			1	μA	
	I _{CC} stn	PS = "L", no load			1	μA	
Current drain	IM	PS = "H", no load	0.3	0.5	0.7	mA	
	I _{CC}	PS = "H", no load	0.9	1.3	1.7	mA	
Thermal shutdown temperature	TSD	Design guarantee		180		°C	
Thermal hysteresis width	ΔTSD	Design guarantee		40		°C	
V _{CC} low voltage cutting voltage	V _{th} V _{CC}		2.1	2.4	2.7	V	
Low voltage hysteresis voltage	V _{th} HIS		100	130	160	mV	
REG5 output voltage	V _{reg5}	I _O = -1mA	4.5	5	5.5	V	
Output on resistance	R _{onU}	I _O = -800mA, Source-side on resistance		0.78	1.0	Ω	
	R _{onD}	I _O = 800mA, Sink-side on resistance		0.32	0.43	Ω	
Output leakage current	I _O leak	V _O = 15V			10	μA	
Diode forward voltage	V _D	I _D = -800mA		1.0	1.2	V	
Logic pin input current	I _{INL}	V _{IN} = 0.8V	4	8	12	μA	
	I _{INH}	V _{IN} = 3.3V	22	33	45	μA	
Logic high-level input voltage	V _{INH}		2.0			V	
Logic low-level input voltage	V _{INL}				0.8	V	
VREF input current	I _{REF}	VREF = 1.0V	-0.5			μA	
Current setting comparator threshold voltage (current step switching)	2W1-2-phase drive	V _{tdac0_2W}	Step 0 (When initialized : channel 1 comparator level)	0.191	0.2	0.209	V
		V _{tdac1_2W}	Step 1 (Initial state+1)	0.187	0.196	0.205	V
		V _{tdac2_2W}	Step 2 (Initial state+2)	0.175	0.184	0.193	V
		V _{tdac3_2W}	Step 3 (Initial state+3)	0.158	0.166	0.174	V
		V _{tdac4_2W}	Step 4 (Initial state+4)	0.132	0.140	0.148	V
		V _{tdac5_2W}	Step 5 (Initial state+5)	0.102	0.110	0.118	V
		V _{tdac6_2W}	Step 6 (Initial state+6)	0.068	0.076	0.084	V
	W1-2-phase drive	V _{tdac0_W}	Step 0 (When initialized : channel 1 comparator level)	0.191	0.200	0.209	V
		V _{tdac2_W}	Step 2 (Initial state+1)	0.175	0.184	0.193	V
		V _{tdac4_W}	Step 4 (Initial state+2)	0.132	0.140	0.148	V
		V _{tdac6_W}	Step 6 (Initial state+3)	0.068	0.076	0.084	V
	1-2 phase drive	V _{tdac0_H}	Step 0 (When initialized : channel 1 comparator level)	0.191	0.200	0.209	V
		V _{tdac4_H}	Step 4 (Initial state+1)	0.132	0.140	0.148	V
	2 phase drive	V _{tdac4_F}	Step 4' (When initialized : channel 1 comparator level)	0.191	0.200	0.209	V
Current setting comparator threshold voltage (current attenuation rate switching)	V _{tatt00}	ATT1 = L, ATT2 = L	0.191	0.200	0.209	V	
	V _{tatt01}	ATT1 = H, ATT2 = L	0.152	0.160	0.168	V	
	V _{tatt10}	ATT1 = L, ATT2 = H	0.112	0.120	0.128	V	
	V _{tatt11}	ATT1 = H, ATT2 = H	0.072	0.080	0.088	V	
Chopping frequency	F _{chop}	C _{chop} = 220pF	36	45	54	kHz	
CHOP pin threshold voltage	V _{CHOPH}		0.6	0.7	0.8	V	
	V _{CHOPL}		0.17	0.2	0.23	V	
CHOP pin charge/discharge current	I _{chop}		7	10	13	μA	
MONI pin saturation voltage	V _{satmon}	I _{moni} = 1mA		250	400	mV	

LV8712T

Package Dimensions

unit : mm (typ)

3260A

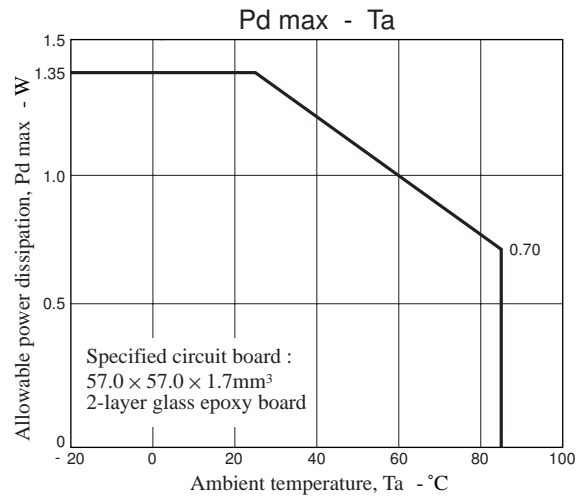
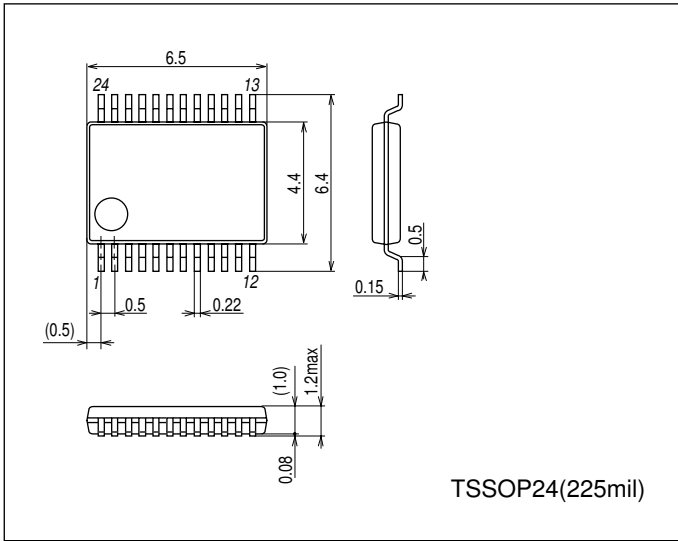

Pin Assignment

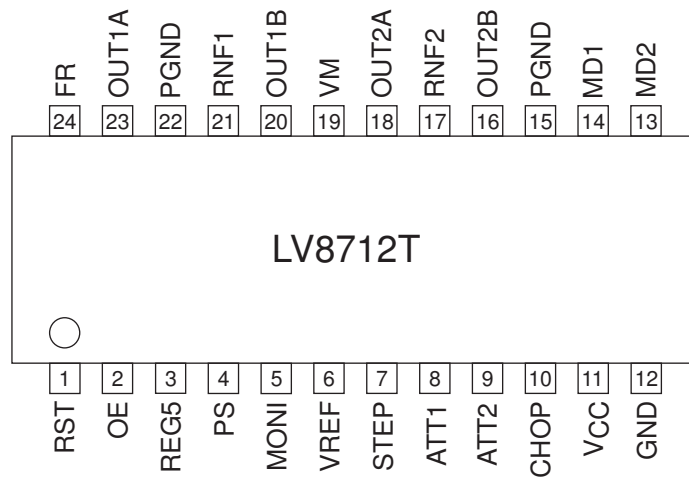

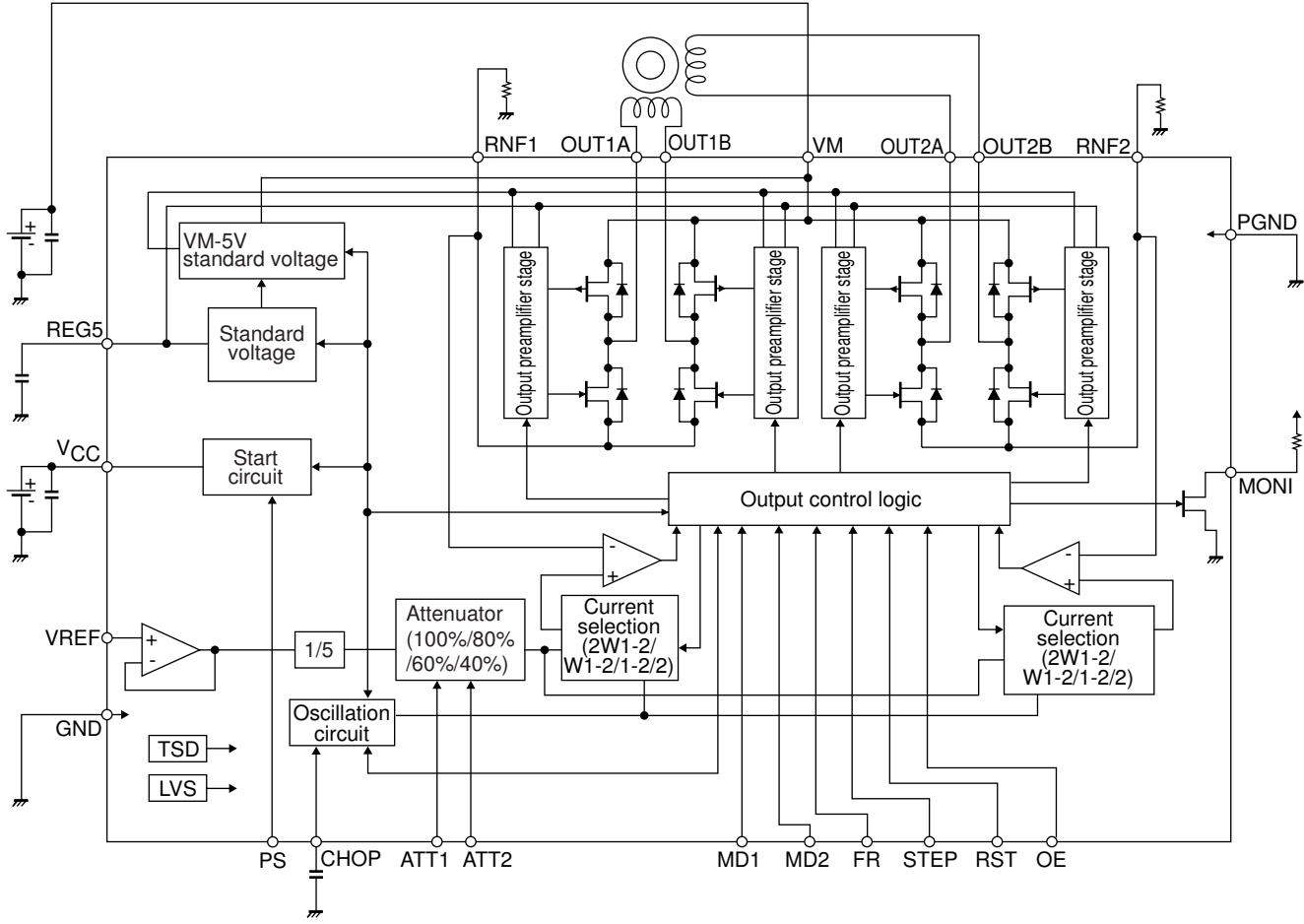

LV8712T

Pin Functions

Pin No.	Pin Name	Pin Function	Equivalent Circuit
1 2 7 8 9 13 14 24	RST OE STEP ATT1 ATT2 MD2 MD1 FR	Excitation reset signal input pin. Output enable signal input pin. STEP signal input pin. Motor holding current switching pin. Motor holding current switching pin. Excitation mode switching pin 2. Excitation mode switching pin 1. CW / CCW switching signal input pin.	
4	PS	Power save signal input pin.	
16 17 18 20 21 23	OUT2B RNF2 OUT2A OUT1B RNF1 OUT1A	Channel 2 OUTB output pin. Channel 2 current-sense resistor connection pin. Channel 2 OUTA output pin. Channel 1 OUTB output pin. Channel 1 current-sense resistor connection pin. Channel 1 OUTA output pin. Power	
6	VREF	Constant current control reference voltage input pin.	

Continued on next page.

Description of operation

Stepping motor control

(1) Power save function

This IC is switched between standby and operating mode by setting the PS pin. In standby mode, the IC is set to power-save mode and all logic is reset. In addition, the internal regulator circuit do not operate in standby mode.

PS	Mode	Internal regulator
Low or Open	Standby mode	Standby
High	Operating mode	Operating

(2) The order of turning on recommended power supply



The order of turning on each power supply recommends the following.

VCC power supply order → VM power supply order → PS pin = High

It becomes the above-mentioned opposite for power supply OFF.

However, the above-mentioned is a recommendation, the overcurrent is not caused by not having defended this, and IC is destroyed.

(3) STEP pin function

Input		Operating mode
PS	STP	
Low	*	Standby mode
High		Excitation step proceeds
High		Excitation step is kept

(4) Excitation mode setting function(initial position)

MD1	MD2	Excitation mode	Initial position	
			Channel 1	Channel 2
Low	Low	2 phase excitation	100%	-100%
High	Low	1-2 phase excitation	100%	0%
Low	High	W1-2 phase excitation	100%	0%
High	High	2W1-2 phase excitation	100%	0%

This is the initial position of each excitation mode in the initial state after power-on and when the counter is reset.

(5) Position detection monitoring function

The MONI position detection monitoring pin is of an open drian type.

When the excitation position is in the initial position, the MONI output is placed in the ON state.

(Refer to "(12) Examples of current waveforms in each of the excitation modes.")

(6) Reset function

RST	Operating mode
High	Normal operation
Low	Reset state

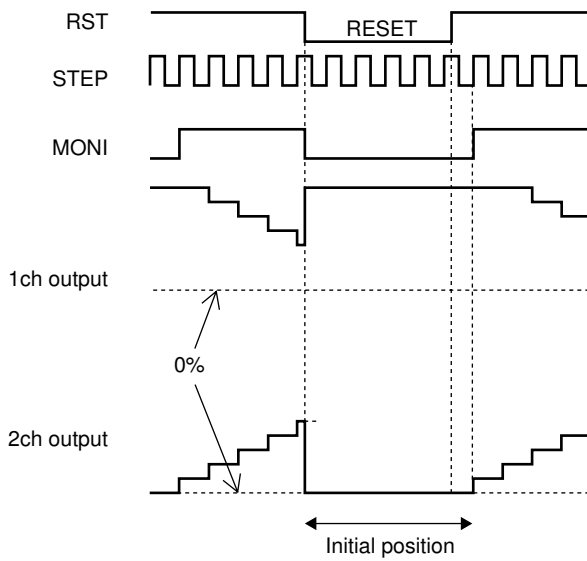

When the RST pin is set to Low, the excitation position of the output is forcibly set to the initial position, and the MONI output is placed in the ON state. When RST is then set to High, the excitation position is advanced by the next STEP input.

(7) Output enable function

OE	Operating mode
Low	Output ON
High	Output OFF

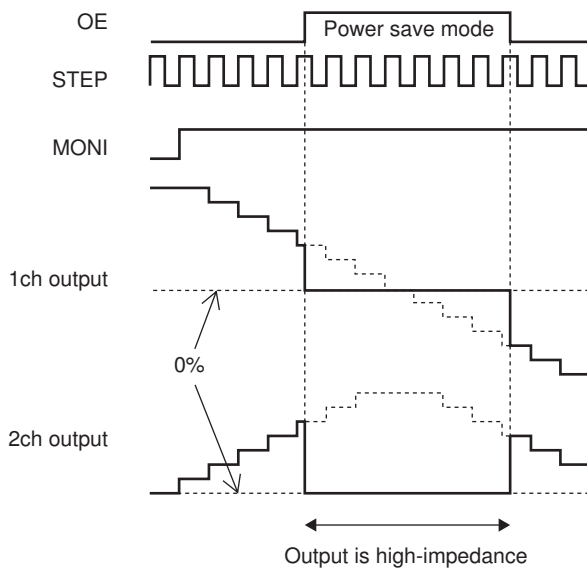

When the OE pin is set High, the output is forced OFF and goes to high impedance.

However, the internal logic circuits are operating, so the excitation position proceeds when the STEP signal is input. Therefore, when OE is returned to Low, the output level conforms to the excitation position proceeded by the STEP input.

(8) Forward/reverse switching function

FR	Operating mode
Low	Clockwise (CW)
High	Counter-clockwise (CCW)

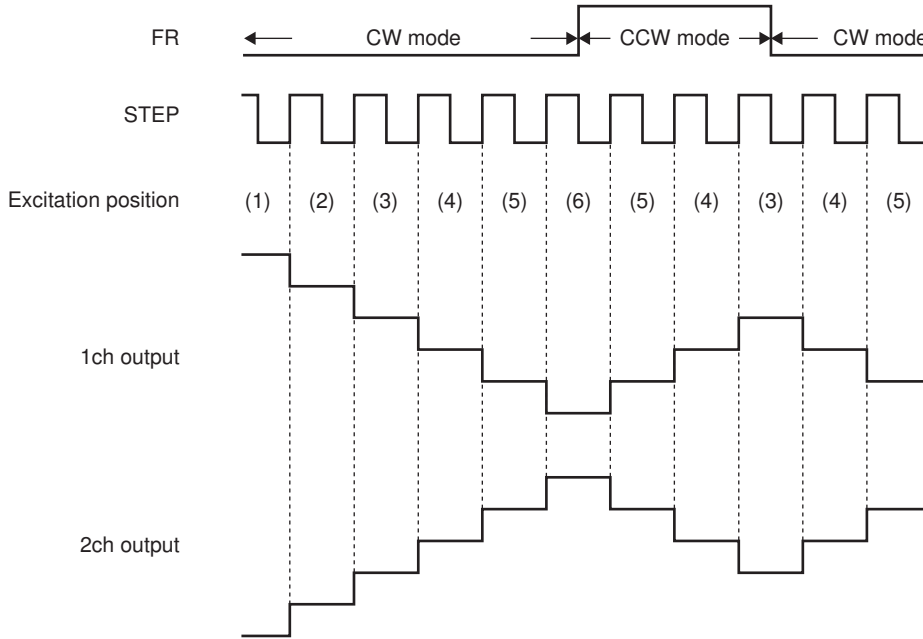

The internal D/A converter proceeds by one bit at the rising edge of the input STEP pulse.
 In addition, CW and CCW mode are switched by setting the FR pin.
 In CW mode, the channel 2 current phase is delayed by 90° relative to the channel 1 current.
 In CCW mode, the channel 2 current phase is advanced by 90° relative to the channel 1 current.

(9) Setting constant-current control

The setting of STM driver's constant current control is decided the VREF voltage from the resistance connected between RNF and GND by the following expression.

$$I_{OUT} = (VREF/5)/RNF \text{ resistance}$$

* The above setting is the output current at 100% of each excitation mode.

The voltage input to the VREF pin can be switched to four-step settings depending on the statuses of the two inputs, ATT1 and ATT2. This is effective for reducing power consumption when motor holding current is supplied.

Attenuation function for VREF input voltage

ATT1	ATT2	Current setting reference voltage attenuation ratio
Low	Low	100%
High	Low	80%
Low	High	60%
High	High	40%

The formula used to calculate the output current when using the function for attenuating the VREF input voltage is given below.

$$I_{OUT} = (VREF/5) \times (\text{attenuation ratio})/RNF \text{ resistance}$$

Example : At VREF of 1.0V, a reference voltage setting of 100% [(ATT1, ATT2) = (L, L)] and an RNF resistance of 0.5Ω, the output current is set as shown below.

$$I_{OUT} = 1.0V/5 \times 100\%/0.5\Omega = 400mA$$

If, in this state, (ATT1, ATT2) is set to (H, H), IOU_T will be as follows :

$$I_{OUT} = 400mA \times 40\% = 160mA$$

In this way, the output current is attenuated when the motor holding current is supplied so that power can be conserved.

LV8712T

(10) Chopping frequency setting

For constant-current control, this IC performs chopping operations at the frequency determined by the capacitor (Cchop) connected between the CHOP pin and GND.

The chopping frequency is set as shown below by the capacitor (Cchop) connected between the CHOP pin and GND.

$$T_{chop} \approx C \times V \times 2 / I \text{ (s)}$$

V : Width of suresshu voltage, typ 0.5V

I : Charge/discharge current, typ 10μA

For instance, when Cchop is 200pF, the chopping frequency will be as follows :

$$F_{chop} \approx 1 / T_{chop} \text{ (Hz)}$$

(11) Output current vector locus (one step is normalized to 90 degrees)

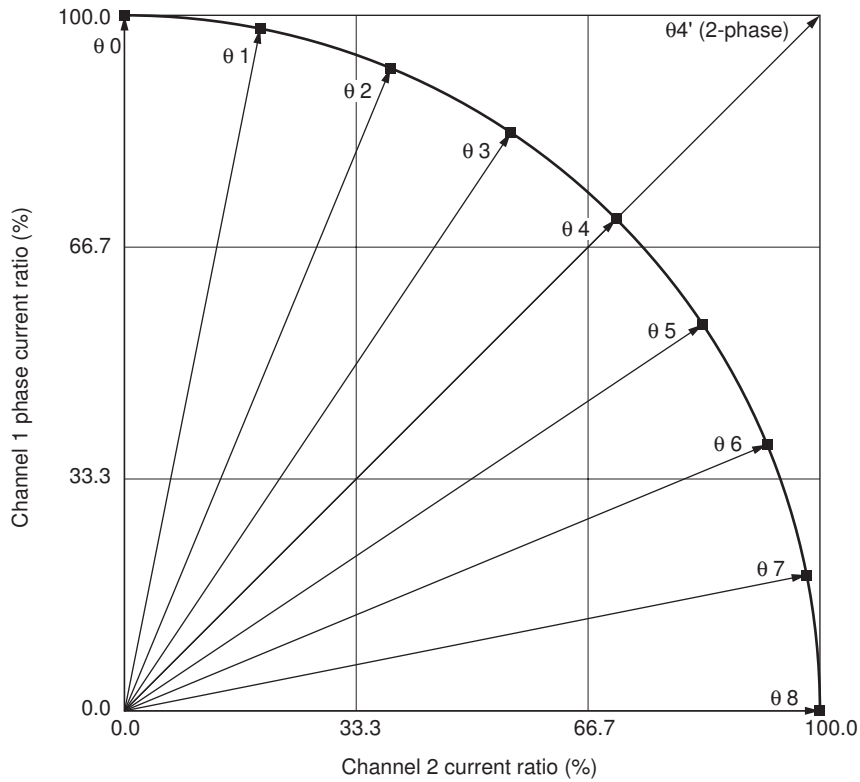

Setting current ration in each excitation mode

STEP	2W1-2 phase (%)		W1-2 phase (%)		1-2 phase (%)		2-phase (%)	
	Channel 1	Channel 2	Channel 1	Channel 2	Channel 1	Channel 2	Channel 1	Channel 2
θ0	100	0	100	0	100	0		
θ1	98	20						
θ2	92	38	92	38				
θ3	83	55						
θ4	70	70	70	70	70	70	100	100
θ5	55	83						
θ6	38	92	38	92				
θ7	20	98						
θ8	0	100	0	100	0	100		

LV8712T

(12) Typical current waveform in each excitation mode

2-phase excitation (CW mode)

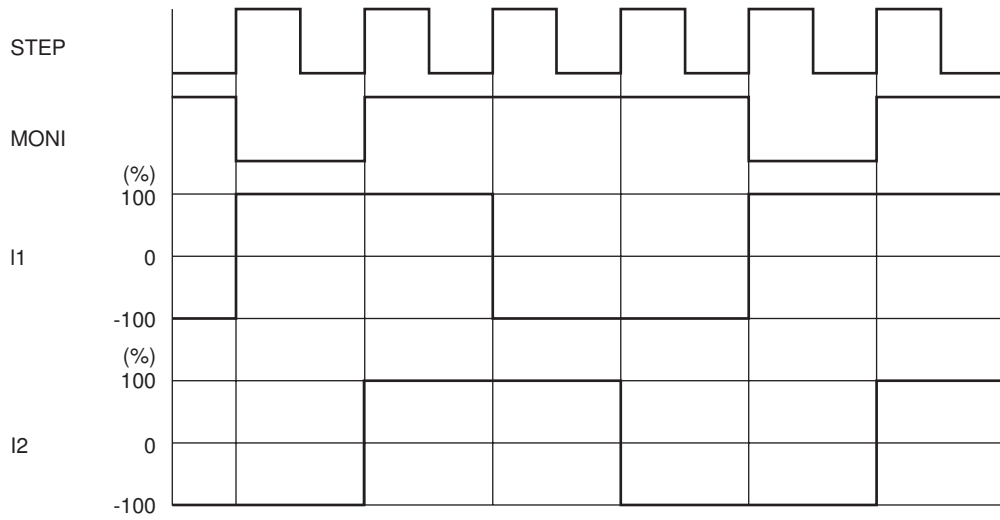

1-2 phase excitation (CW mode)

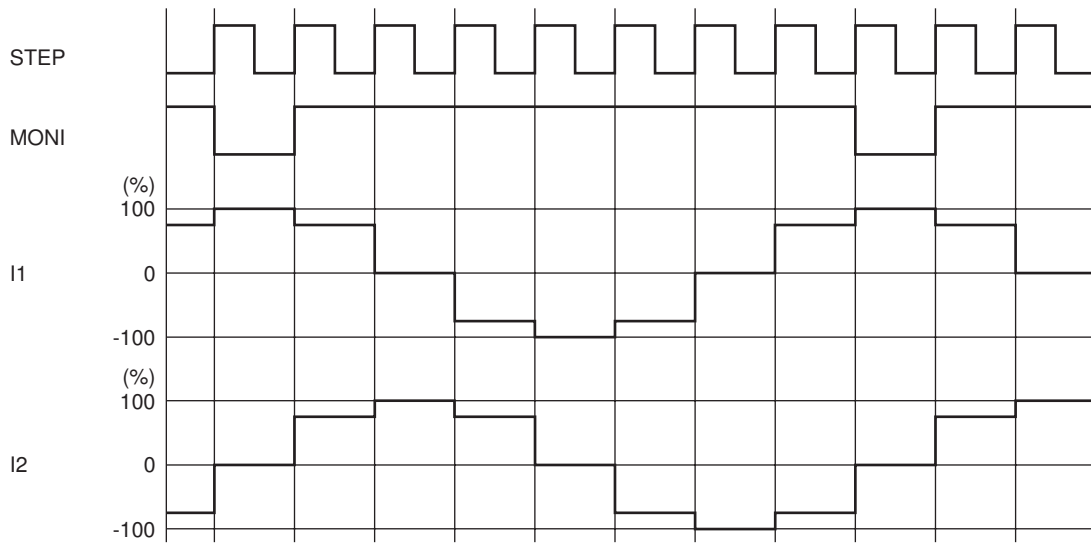

LV8712T

W1-2 phase excitation (CW mode)

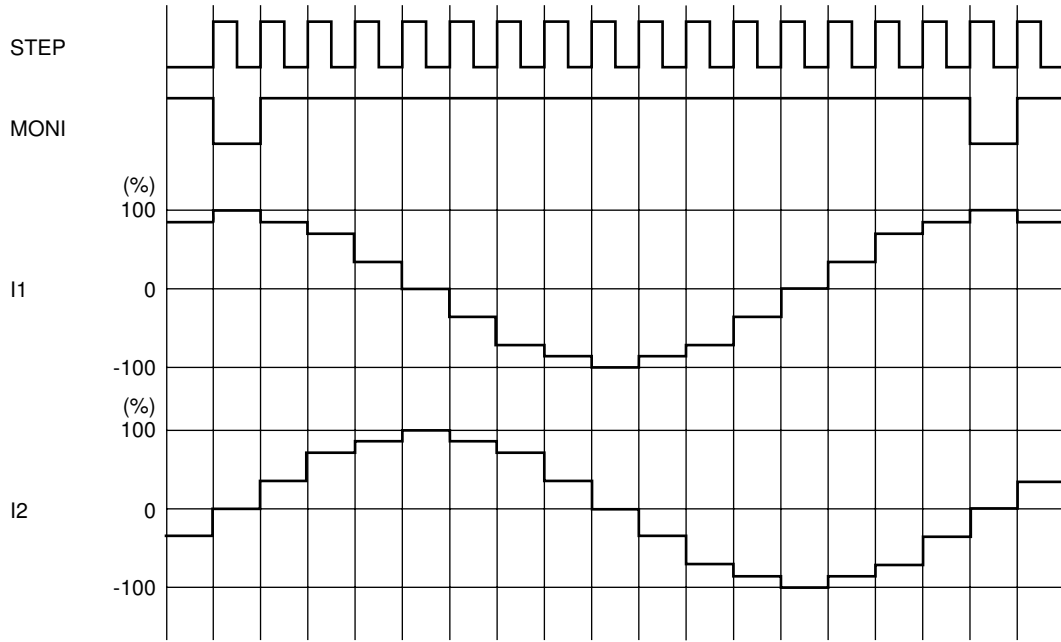

2W1-2 phase excitation (CW mode)

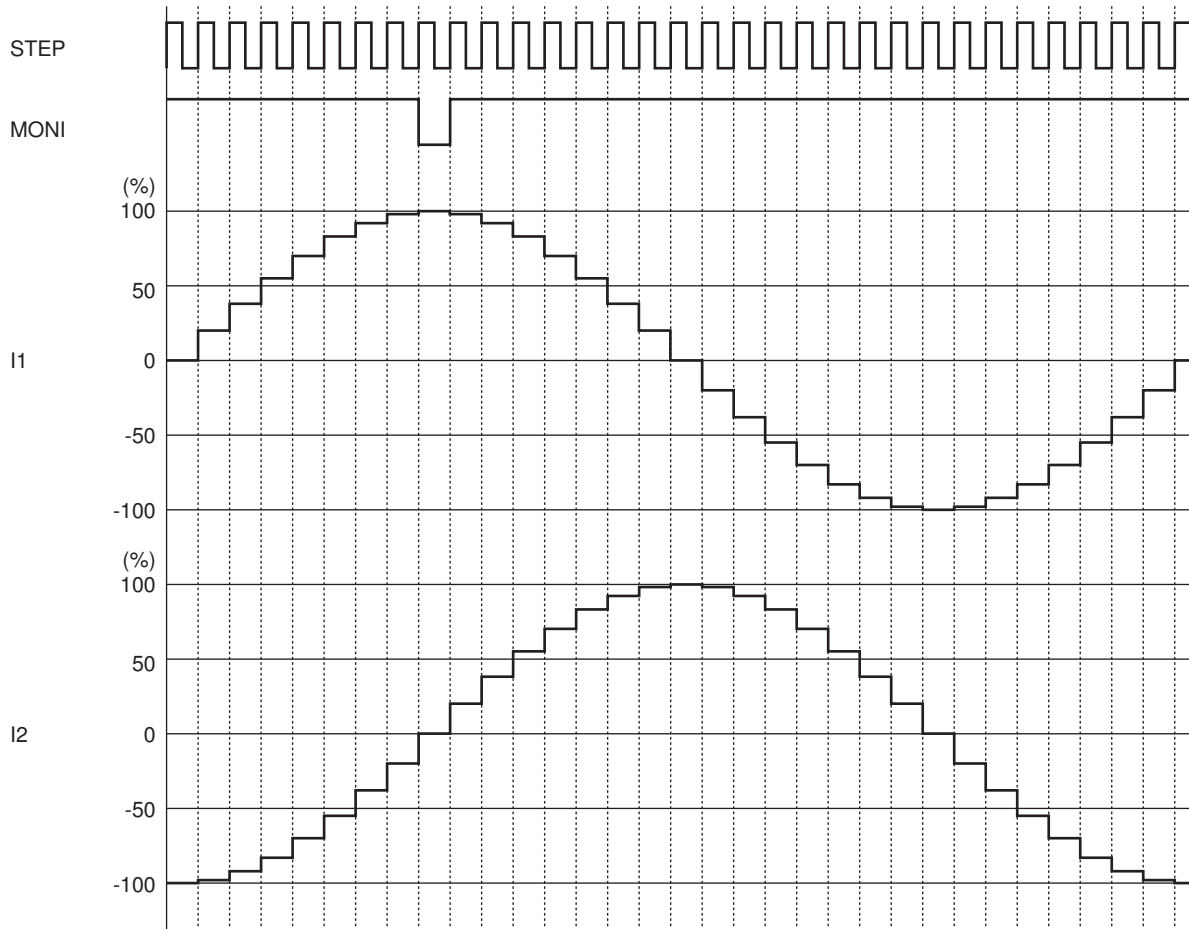

(13) Current control timing chart(Chopping operation)

(Sine wave increasing direction)

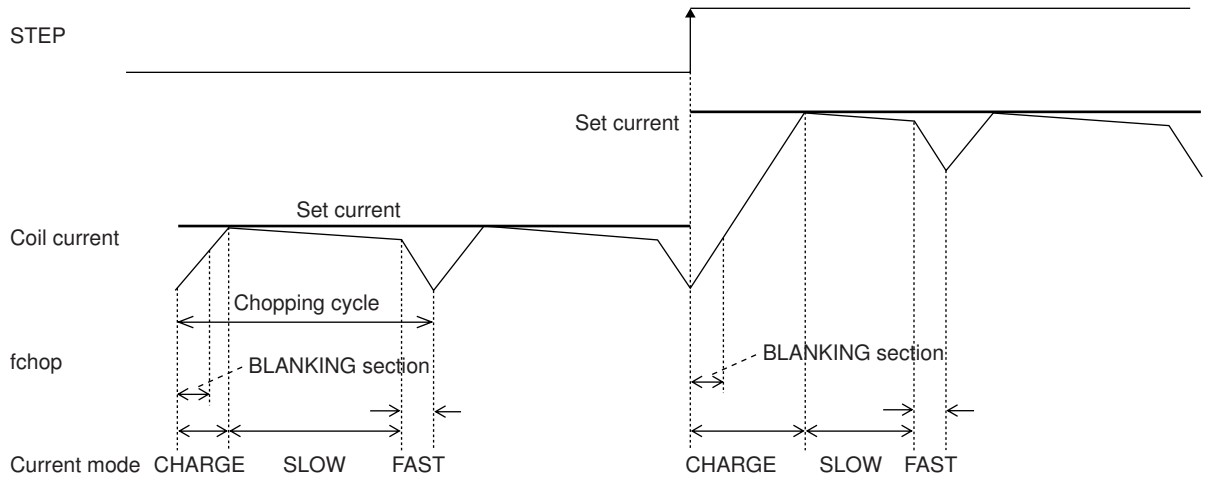

(Sine wave decreasing direction)

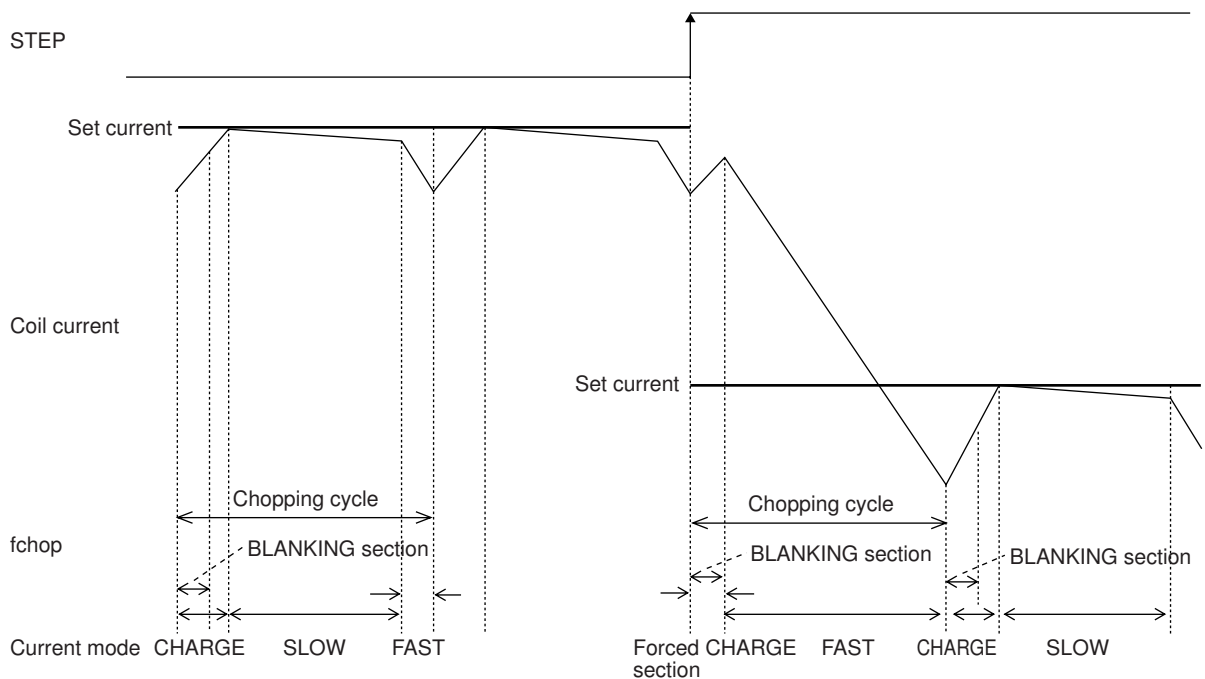

In each current mode, the operation sequence is as described below :

- At rise of chopping frequency, the CHARGE mode begins. (The Blanking section in which the CHARGE mode is forced regardless of the magnitude of the coil current (ICOIL) and set current (IREF) exists for 1μs.)
- The coil current (ICOIL) and set current (IREF) are compared in this blanking time.

When (ICOIL < IREF) state exists ;

The CHARGE mode up to $ICOIL \geq IREF$, then followed by changeover to the SLOW DECAY mode, and finally by the FAST DECAY mode for approximately 1μs.

When (ICOIL < IREF) state does not exist ;

The FAST DECAY mode begins. The coil current is attenuated in the FAST DECAY mode till one cycle of chopping is over.

Above operations are repeated. Normally, the SLOW (+FAST) DECAY mode continues in the sine wave increasing direction, then entering the FAST DECAY mode till the current is attenuated to the set level and followed by the SLOW DECAY mode.

Application Circuit Example

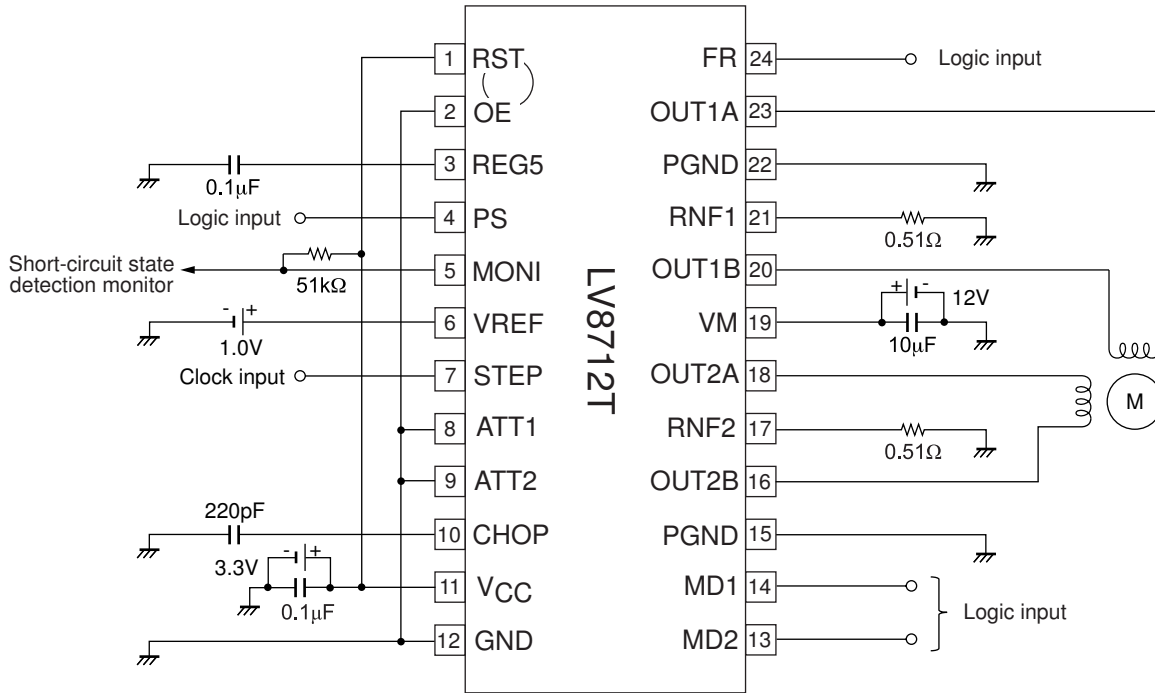

The formulae for setting the constants in the examples of the application circuits above are as follows :

Constant current (100%) setting

When VREF = 1.0V

$$I_{OUT} = VREF/5/RNF \text{ resistance}$$

$$= 1.0V/5/0.51\Omega = 0.392A$$

Chopping frequency setting

$$F_{chop} = I_{chop}/(C_{chop} \times V_{tchop} \times 2)$$

$$= 10\mu A/(220pF \times 0.5V \times 2) = 45kHz$$

ON Semiconductor and the ON logo are registered trademarks of Semiconductor Components Industries, LLC (SCILLC). SCILLC owns the rights to a number of patents, trademarks, copyrights, trade secrets, and other intellectual property. A listing of SCILLC's product/patent coverage may be accessed at www.onsemi.com/site/pdf/Patent-Marking.pdf. SCILLC reserves the right to make changes without further notice to any products herein. SCILLC makes no warranty, representation or guarantee regarding the suitability of its products for any particular purpose, nor does SCILLC assume any liability arising out of the application or use of any product or circuit, and specifically disclaims any and all liability, including without limitation special, consequential or incidental damages. "Typical" parameters which may be provided in SCILLC data sheets and/or specifications can and do vary in different applications and actual performance may vary over time. All operating parameters, including "Typicals" must be validated for each customer application by customer's technical experts. SCILLC does not convey any license under its patent rights nor the rights of others. SCILLC products are not designed, intended, or authorized for use as components in systems intended for surgical implant into the body, or other applications intended to support or sustain life, or for any other application in which the failure of the SCILLC product could create a situation where personal injury or death may occur. Should Buyer purchase or use SCILLC products for any such unintended or unauthorized application, Buyer shall indemnify and hold SCILLC and its officers, employees, subsidiaries, affiliates, and distributors harmless against all claims, costs, damages, and expenses, and reasonable attorney fees arising out of, directly or indirectly, any claim of personal injury or death associated with such unintended or unauthorized use, even if such claim alleges that SCILLC was negligent regarding the design or manufacture of the part. SCILLC is an Equal Opportunity/Affirmative Action Employer. This literature is subject to all applicable copyright laws and is not for resale in any manner.