



ON Semiconductor®

<http://onsemi.com>

# LA6565VR

Monolithic Linear IC

## Five-Channel CD Actuator Driver (BTL: 4 channels, H bridge: 1 channel)

### Overview

The LA6565VR is a four-channel BTL plus one-channel H bridge actuator driver developed for use in CD and DVD drives. The BTL driver channels 1 and 2 include built-in operational amplifiers allowing the LA6565VR to support a wide range of applications.

### Functions and Features

- Five power amplifier channels on a single chip (Bridge connection (BTL): 4 channels, H bridge: 1 channel)
- $I_O$  max: 1A
- Built-in level shifters (except for the H bridge channel)
- Muting circuits (output on/off, two systems)  
(The muting circuits operate for the BTL amplifiers. They do not apply to the H bridge or regulator circuits.)
- Built-in regulator (Uses an external PNP transistor and is set with an external resistor.)
- Output voltage setting function (loading driver)
- Built-in independent operational amplifiers
- Thermal shutdown circuit

### Specifications

**Maximum Ratings** at  $T_a = 25^\circ\text{C}$

Parameter	Symbol	Conditions	Ratings	Unit
Supply voltage	$V_{CC}$ max		14	V
Allowable power dissipation	$P_d$ max	Independent IC	0.55	W
		Mounted on a specified board	1.70	W
Maximum output current	$I_O$ max	For each of the channel 1 to 4 and H bridge outputs	1	A
Maximum input voltage	$V_{INB}$		13	V
MUTE pin voltage	$V_{MUTE}$		13	V
Operating temperature	$T_{opr}$		-30 to +85	$^\circ\text{C}$
Storage temperature	$T_{stg}$		-55 to +150	$^\circ\text{C}$

\* Mounted on a specified board: 76.1mm×114.3mm×1.6mm glass epoxy

Stresses exceeding Maximum Ratings may damage the device. Maximum Ratings are stress ratings only. Functional operation above the Recommended Operating Conditions is not implied. Extended exposure to stresses above the Recommended Operating Conditions may affect device reliability.

# LA6565VR

## Recommended Operating Conditions at $T_a = 25^\circ\text{C}$

Parameter	Symbol	Conditions	Ratings	Unit
Supply voltage	$V_{CC}$		5.6 to 13	V

## Electrical Characteristics at $T_a = 25^\circ\text{C}$ , $V_{CCS} = V_{CCP1} = V_{CCP2} = 8\text{V}$ , $V_{REF} = 2.5\text{V}$

Parameter	Symbol	Conditions	Ratings			Unit
			min	typ	max	
[Overall]						
Quiescent current when on	$I_{CC-ON}$	BTL amplifier output on, loading block off *1		30	50	mA
Quiescent current when off	$I_{CC-OFF}$	All outputs off *1		10	15	mA
Thermal shutdown circuit operating temperature	TSD	*7	150	175	200	$^\circ\text{C}$
[VREF Amplifier]						
VREF amplifier offset voltage	VREF- OFFSET		-10		10	mV
VREF input voltage range	VREF-IN		1		$V_{CC}-1.5$	V
VREF-OUT output current	I-VREF-OUT			1		mA
[Operational Amplifier] (Independent)						
Input voltage range	$V_{IN}$ (OP)		0		$V_{CC}-1.5$	V
Output current (sink)	SINK (OP)		2			mA
Output current (source)	SOURCE (OP)		300	500		$\mu\text{A}$
Output offset voltage	VOFF (OP)		-10		10	mV
Residual current (sink)	VCE-SINK (OP)	$I_O$ (sink side) = 1mA			0.6	V
[BTL Amplifier Block] (Channels 1 to 4)						
Output offset voltage	VOFF	The voltage difference between each channel outputs *2, *3	-50		50	mV
Input voltage range	$V_{IN}$	Input voltage range of the input operational amplifiers	0		$V_{CC}-1.5$	V
Output voltage	$V_O$	$I_O = 0.5\text{A}$ , the voltage between $V_{O+}$ and $V_{O-}$ in each channel	5.7	6.2		V
Closed circuit voltage gain	VG	The gain from the input to the output with the input amplifier set to 0dB *2, *3	7.2	8	9	times
Slew rate	SR	For the independent amplifier. Times 2 when between outputs *7		0.5		$\text{V}/\mu\text{s}$
Muting on voltage	VMUTE-ON	The output on voltage, for each mute function *4	2.5			V
Muting off voltage	VMUTE-OFF	The output off voltage, for each mute function *4			0.5	V
[Input Amplifier Block] (Channels 1 and 2)						
Input voltage range	$V_{IN-OP}$		0		$V_{CC}-1.5$	V
Output current (sink)	SINK-OP		2			mA
Output current (source)	SOURCE-OP	*5	300	500		$\mu\text{A}$
Output offset voltage	VOFF-OP		-10		10	mV
[Loading Block] (Channel 5, H bridge circuit)						
Output voltage	$V_{O-LOAD}$	For forward/reverse operation, $I_O = 0.5\text{A}$ , $V_{CONT} = V_{CC}^*$	5.7	6.5		V
Braking output saturation voltage	$V_{CE-BREAK}$	The output voltage during braking *6			0.3	V
Low-level input voltage	$V_{IN-L}$				1	V
High-level input voltage	$V_{IN-H}$		2			V

\*1: The total current dissipation for  $V_{CCP1}$ ,  $V_{CCP2}$ , and  $V_{CCS}$  with no load.

\*2: The input amplifier is a buffer amplifier.

\*3: The voltage difference between the two sides of the load ( $12\Omega$ ).

\*4: When the MUTE pin is high, the output will be on, and when low, the output will be off (high-impedance state).

\*5: The input operational amplifier source is constant current. Since the  $11\text{k}\Omega$  resistor between this and the next stage functions as the load, the input operational amplifier gain must be set carefully.

\*6: The braking operation is a short (to ground) braking operation. The sink side output is on at this time.

\*7: Design guarantee.

Continued on next page.



# LA6565VR

## Pin Functions

Pin No.	Pin Name	Description
1	FWD	LOADING output changeover pin (FWD), LOADING logic input
2	REV	LOADING output changeover pin (REV), LOADING logic input
3	V <sub>CC2</sub>	LOADING power-stage power supply for channel 3 and 4
4	NC	-
5	VLO <sup>-</sup>	Loading output (-)
6	VLO <sup>+</sup>	Loading output (+)
7	V <sub>O4</sub> <sup>+</sup>	Output pin (+) for channel 4
8	V <sub>O4</sub> <sup>-</sup>	Output pin (-) for channel 4
9	V <sub>O3</sub> <sup>+</sup>	Output pin (+) for channel 3
10	V <sub>O3</sub> <sup>-</sup>	Output pin (-) for channel 3
11	PGND2	Power system GND
12	PGND1	Power system GND
13	V <sub>O2</sub> <sup>+</sup>	Output pin (+) for channel 2
14	V <sub>O2</sub> <sup>-</sup>	Output pin (-) for channel 2
15	V <sub>O1</sub> <sup>-</sup>	Output pin (+) for channel 1
16	V <sub>O1</sub> <sup>+</sup>	Output pin (-) for channel 1
17	NC	-
18	V <sub>CCP1</sub>	Power-stage power supply for channel 1 and 2
19	V <sub>CCS</sub>	Signal system power supply
20	V <sub>IN1</sub> <sup>+</sup>	Input pin for channel 1, Input OP-AMP (+) input
21	V <sub>IN1</sub> <sup>-</sup>	Input pin for channel 1, Input OP-AMP (-) input
22	V <sub>IN1</sub>	Input pin for channel 1, Input OP-AMP output
23	NC	-
24	V <sub>IN2</sub> <sup>+</sup>	Input pin for channel 2, Input OP-AMP (+) input
25	V <sub>IN2</sub> <sup>-</sup>	Input pin for channel 2, Input OP-AMP (-) input
26	V <sub>IN2</sub>	Input pin for channel 2, Input OP-AMP output
27	NC	-
28	V <sub>IN3</sub> <sup>-</sup>	Input pin for channel 3, Input OP-AMP (-) input
29	V <sub>IN3</sub>	Input pin for channel 3, Input OP-AMP output
30	V <sub>O</sub> _OP	OP-AMP, output pin
31	V <sub>IN</sub> <sup>-</sup> OP	OP-AMP, (-) input pin
32	V <sub>IN</sub> <sup>+</sup> OP	OP-AMP, (+) input pin
33	REG_IN	Regulator, error AMP output pin. Base to external PNP transistor connected
34	NC	-
35	REG_OUT	Regulator, error AMP input pin (+)
36	VREF_OUT	VREF_AMP (voltage follower) output pin
37	VREF_IN	VREF input pin. Input the external reference voltage
38	V <sub>IN4</sub>	Input pin for channel 4, Input OP-AMP output
39	NC	-
40	V <sub>IN4</sub> <sup>-</sup>	Input pin for channel 4, Input OP-AMP (-) input
41	MUTE234	Output ON/OFF pin for channel 2, 3 and 4
42	MUTE1	Output ON/OFF pin for channel 1
43	VCONT	LOADING output (H voltage) setting pin
44	S_GND	Signal system GND

# LA6565VR

## Pin Description

Pin No.	Pin Name	Pin Name	Description	Equivalent Circuit Diagram Description
20 21 22 24 25 26 28 29 38 40 32 31 30	$V_{IN1+}$ $V_{IN1-}$ $V_{IN1}$ $V_{IN2+}$ $V_{IN2-}$ $V_{IN2}$ $V_{IN3+}$ $V_{IN3-}$ $V_{IN3}$ $V_{IN4+}$ $V_{IN4-}$ $V_{IN4}$ $V_{IN+OP}$ $V_{IN-OP}$ $V_{O\_OP}$	Input (CH1 to 4)	Inputs (channels 1 to 4 and the independent operational amplifier)	
1 2	FWD REV	Input (H bridge)	Logic inputs The IC is set to one of four modes, forward, reverse, brake, and free running by the combination of high and low values applied to these pins.	
16 15 13 14 9 10 7 8	$V_{O1+}$ $V_{O1-}$ $V_{O2+}$ $V_{O2-}$ $V_{O3+}$ $V_{O3-}$ $V_{O4+}$ $V_{O4-}$	Output (BTL-AMP)	Channel 1 to 4 outputs	
5 6 43	$V_{LO-}$ $V_{LO+}$ VCONT	Output (H bridge)	H bridge (loading) output and loading output setting	
41 42	MUTE234 MUTE1	MUTE	BTL amplifier output on/off state setting. High: output on Low: output off	

**Truth Table (Loading (H bridge) block)**

FWD	REV	VLO+	VLO-	Loading output
L	L	OFF	OFF	OFF *1
	H	H	L	Forward
H	L	L	H	Reverse
	H	L	L	Short-circuit braking *2

\*1. The output goes to the high-impedance state.

\*2. In braking mode, the sink side transistor is turned on (for short-circuit braking).

The VLO+ and VLO- pins go to a level that is essentially the ground level.

**Relationship Between The MUTE Pins and The Power Supply Systems (VCCP\*)**

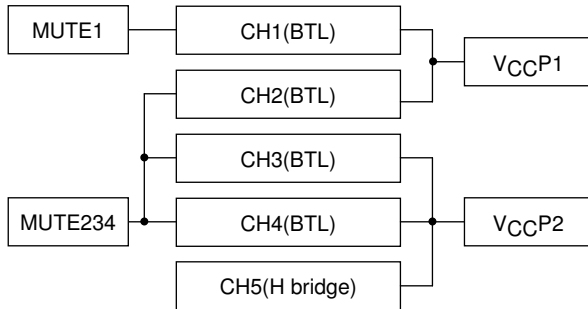

# LA6565VR

## Internal Block Diagram

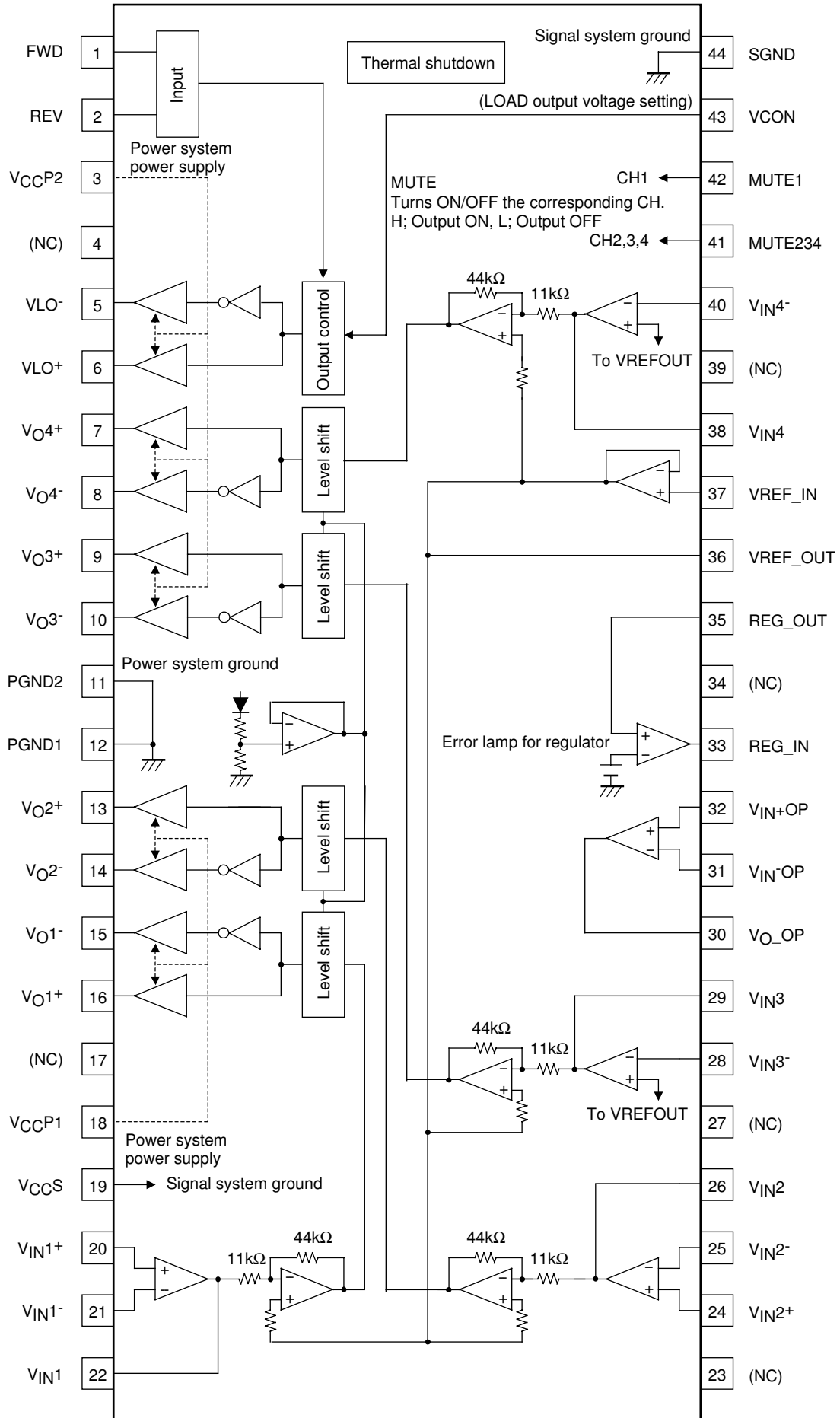

# LA6565VR

## Sample Application Circuit

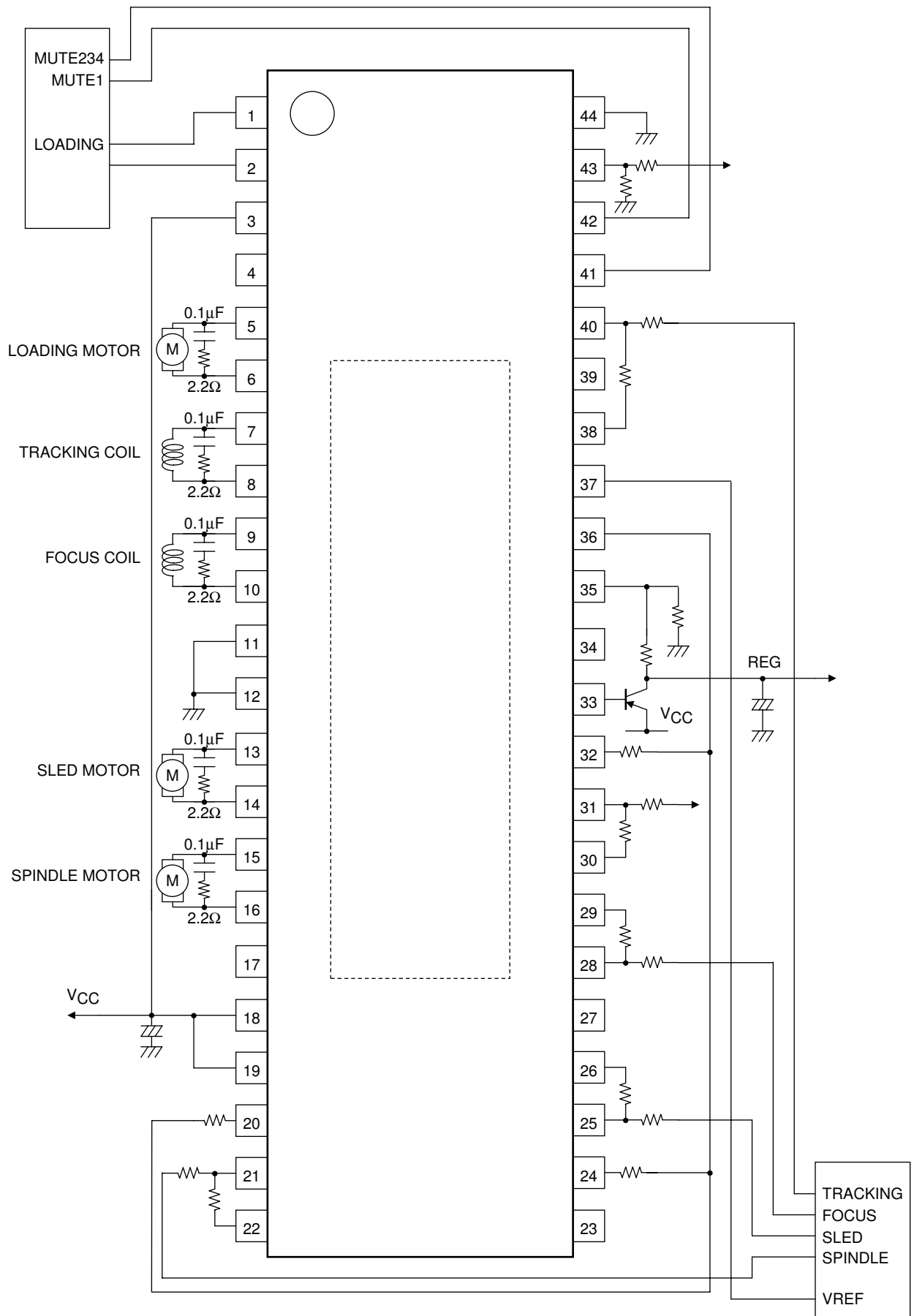

ON Semiconductor and the ON logo are registered trademarks of Semiconductor Components Industries, LLC (SCILLC). SCILLC owns the rights to a number of patents, trademarks, copyrights, trade secrets, and other intellectual property. A listing of SCILLC's product/patent coverage may be accessed at [www.onsemi.com/site/pdf/Patent-Marking.pdf](http://www.onsemi.com/site/pdf/Patent-Marking.pdf). SCILLC reserves the right to make changes without further notice to any products herein. SCILLC makes no warranty, representation or guarantee regarding the suitability of its products for any particular purpose, nor does SCILLC assume any liability arising out of the application or use of any product or circuit, and specifically disclaims any and all liability, including without limitation special, consequential or incidental damages. "Typical" parameters which may be provided in SCILLC data sheets and/or specifications can and do vary in different applications and actual performance may vary over time. All operating parameters, including "Typicals" must be validated for each customer application by customer's technical experts. SCILLC does not convey any license under its patent rights nor the rights of others. SCILLC products are not designed, intended, or authorized for use as components in systems intended for surgical implant into the body, or other applications intended to support or sustain life, or for any other application in which the failure of the SCILLC product could create a situation where personal injury or death may occur. Should Buyer purchase or use SCILLC products for any such unintended or unauthorized application, Buyer shall indemnify and hold SCILLC and its officers, employees, subsidiaries, affiliates, and distributors harmless against all claims, costs, damages, and expenses, and reasonable attorney fees arising out of, directly or indirectly, any claim of personal injury or death associated with such unintended or unauthorized use, even if such claim alleges that SCILLC was negligent regarding the design or manufacture of the part. SCILLC is an Equal Opportunity/Affirmative Action Employer. This literature is subject to all applicable copyright laws and is not for resale in any manner.