

PSL-245
1460 nm Single Mode Laser in TO39

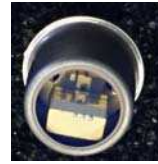

1. PRODUCT DESCRIPTION

The Princeton Lightwave PSL-245 is a high power single mode 1460nm InP based laser package in a standard TO-39 / TO-5 header hermetically sealed with an AR coated window.

2. PERFORMANCE SPECIFICATIONS

Parameter	Symbol	Conditions	Min	Typ	Max	Units
Center Wavelength	λ	Pulsed mode with 1% duty cycle and 3 ms pulse duration, 25°C, $I_{op} = 1.0$ A	1440	1460	1480	nm
Drive Current (Pulsed)	I_{op}	Pulsed operation (1% Duty cycle 3 ms pulse duration, 25°C), $P_{op} = 350$ mW		1.0	1.5	A
Monitor Current	I_{mon}	Pulsed mode with 1% duty cycle and 3 ms pulse duration, 25°C, $I_{op} = 1.0$ A	0.3	1.0		mA
Forward Voltage	V_{op}	At rated power		2.4	3.8	V

3. MAXIMUM RATINGS

Parameter	Min	Max	Units
Laser Diode			
Forward Current		1.7	A
Reverse Voltage		2	V
Operating Temperature	-40	85	°C
Monitor Photodiode			
Forward Current		5	mA
Reverse Voltage		20	V
Package			
Storage Temperature	-40	85	°C
Lead Soldering Temperature (10 sec. max)		260	°C

Maximum ratings indicate conditions under which the device may be damaged during short periods of time and which should be avoided.

3. MECHANICAL SPECIFICATIONS

The TO-39 package contains single mode laser diode mounted on an AlN submount and aligned to a back facet monitor. These are assembled on a header with a copper-tungsten pedestal for maximum heat sinking and thermal performance. To achieve the best performance minimize the possibility of damage to the laser, adequate heat sinking or cooling should be used.

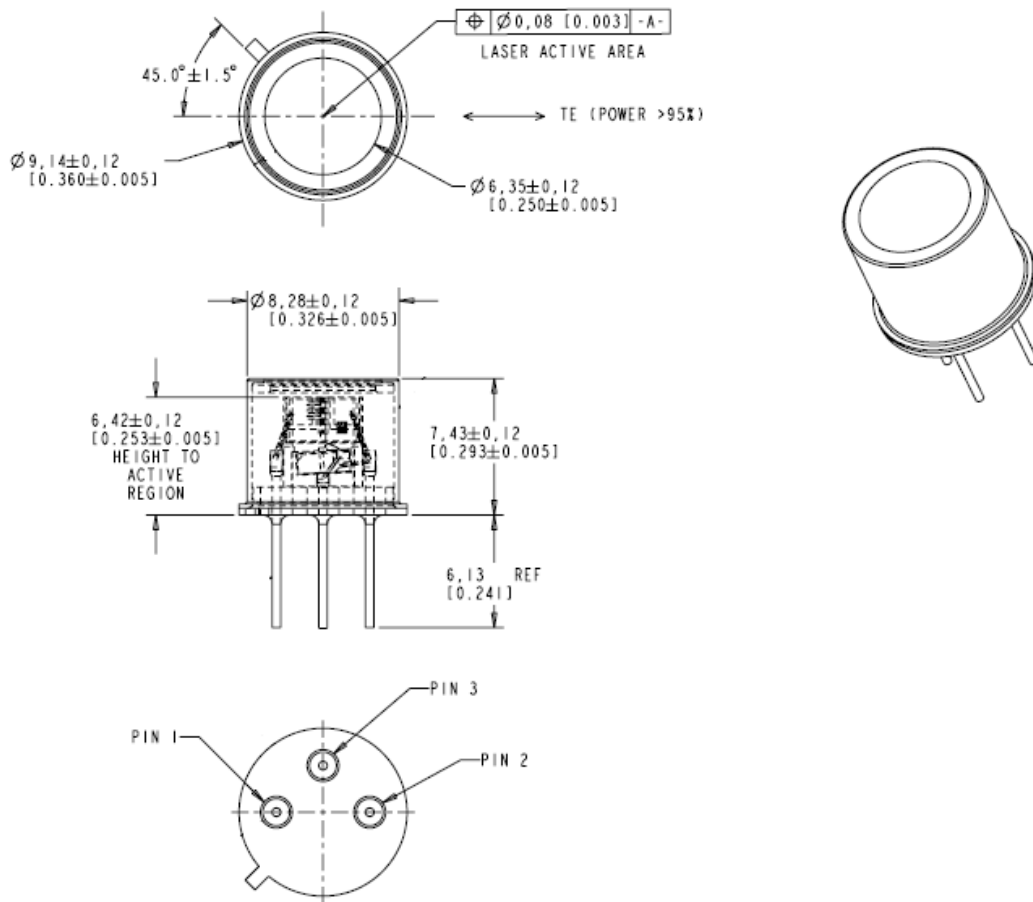

TO-39 Pin-out

Pin	Description
#1	LD Cathode
#2	LD Anode PD Cathode
#3	PD Anode

4. PRODUCT HANDLING

These lasers are sensitive to electrostatic discharge (ESD) and should be handled with appropriate caution, including the use of ESD protective equipment such as grounding straps and anti-static mats.