



# PRELIMINARY

## 1064nm Single Photon Avalanche Diode (SPAD) PGA-284

### 1. PRODUCT DESCRIPTION

The Princeton Lightwave SPAD is an InGaAs/InP avalanche photodetector designed specifically for single photon counting applications. The device is intended for use at voltage biases above the breakdown voltage (in the so-called “Geiger mode”) so that a single photon incident on the detector will give rise to a macroscopic current pulse. Combined with appropriate pulse detection circuitry, this device allows for the detection of single photons in the wavelength range from 0.95 to 1.1  $\mu\text{m}$ .

The PLI SPAD described in this datasheet is a back-illuminated device provided in a standard TO-46 can with a window cap.

### 2. PERFORMANCE SPECIFICATIONS

Parameter Description	Test Conditions	Specifications			Unit
		Min	Typ	Max	
Effective Optical Diameter			80		$\mu\text{m}$
<b>Linear Mode Parameters</b> (case temperature 295K, all voltages and currents are reverse biased)					
Breakdown voltage, $V_b$	$I_d = 10 \mu\text{A}$	80	90	100	V
Temperature dependence of $V_b, \gamma$	Between 300K and 150K, linear approximation		0.15		%/K
Quantum Efficiency, QE	1064 nm, M=1 (Linear mode)		75		%
Total Dark Current, $I_d$	M=10; primarily non-multiplied $I_d$		10		nA
Capacitance, C	M=10, 1 MHz		1.5		pF
<b>Geiger Mode Parameters</b>					
Dark Count Rate, DCR	case temperature 233 K, 3 V overbias			100	kHz
Detection Efficiency, DE [1]	case temperature 233 K, 1064nm, 3 V overbias		20		%

[1] Typical value achieved by design, not tested on shipped product.

### 3. MAXIMUM RATINGS

Parameter	Conditions	Min.	Max.	Units
Forward Current	Continuous bias		1	mA
Forward Voltage	Continuous bias		1	V
Reverse Current	Continuous bias		1	mA
Reverse Voltage	Continuous bias		$(V_b + 5)$	V
Reverse Voltage	Pulsed (gated operation)		$(V_b + 10)$	V
Optical Power	Continuous wave (CW)		1	mW
Case Temperature		-65	65	$^{\circ}\text{C}$

Maximum ratings indicate conditions that the device can be exposed to for short periods of time without damage. Although InGaAs SPADs are sometimes operated at temperatures below  $-60^{\circ}\text{C}$ , these devices have not yet been tested to establish their reliability characteristics at very low temperatures and under extreme conditions of thermal cycling.

#### 4. MECHANICAL SPECIFICATIONS

The TO-46 package contains the back-illuminated SPAD on a custom submount and is hermetically sealed with a flat window cap. Anode and cathode leads are isolated from the case ground.

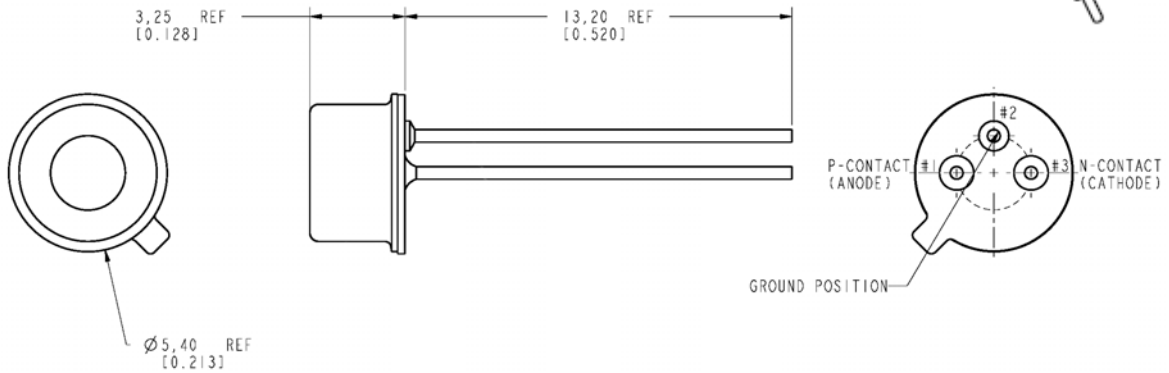
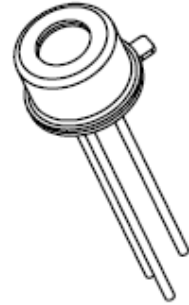

#### TO-46 Pin-out

Pin	Description
#1	P-contact (Anode)
#2	Case Ground
#3	N-contact (Cathode)

#### 5. PRODUCT HANDLING

These avalanche photodiodes are sensitive to electrostatic discharge (ESD) and should be handled with appropriate caution, including the use of ESD protective equipment such as grounding straps and anti-static mats.