



**PGA-308
Cooled Single Photon Counting
Avalanche Photodiode – Fiber Pigtailed**



The Princeton Lightwave SPAD is an InGaAs/InP avalanche photodetector designed specifically for single photon counting applications. The device is intended for use at pulsed voltage biases above the breakdown voltage (in the so-called “Geiger mode”) so that a single photon incident on the detector will give rise to a macroscopic current pulse. Combined with appropriate pulse detection circuitry, this device allows for the detection of single photons in the wavelength range from 0.95 to 1.6 μm .

The PLI SPAD described in this datasheet is a fiber-pigtailed device provided in a standard three-stage cooled 6 pin TO-8 can. A single mode fiber is coupled to the SPAD. It is available in an ultra high sensitivity version with dark count rate of 10KHz or less at a detection efficiency of 20%

PERFORMANCE SPECIFICATIONS

Linear Mode Parameters ($T_{OP}=298\text{K}$, all voltages and currents are reverse biased)

Parameter Description	Test Conditions	Specifications			Unit
		Min	Typical	Max	
Effective Optical Diameter			25		μm
Breakdown voltage, (V_B)	at $I_d = 10 \mu\text{A}$	50	70	90	V
Temperature dependence of V_B, λ	Between 300K and 150K, linear approximation		0.15		%/K
Quantum Efficiency, (QE)	1550 nm, M=1 (Linear mode) 1300 nm, M=1 (Linear mode)		60 75		%
Responsivity, (R)	1550 nm, M=1 (Linear mode) 1300 nm, M=1 (Linear mode)		0.75 0.75		A/W
Total Dark Current, (I_D)	M=10; primarily non-multiplied I_d		0.3		nA
Capacitance, (C)	M=10, 1 MHz		0.25		pF

Geiger Mode Parameters ($T_{OP}=223\text{K}$)

Parameter Description	Test Conditions	PGA-308 High Sensitivity Detector		PGA-308-U Ultra High Sensitivity Detector		Unit
		Min	Max	Min	Max	
Detection Efficiency, (DE)	at DCR maximum	20		20		%
Dark Count Rate, (DCR)	at DE minimum		75		10	kHz

Princeton Lightwave Inc.
Subject to change without notice

v.4.1 – 09/10/2010

2555 US Route 130 S.
Cranbury, NJ 08540
Tel: 609-495-2600
<http://www.princetonlightwave.com>
© 2010, Princeton Lightwave, Inc.



ABSOLUTE MAXIMUM RATINGS

Parameter	Conditions	Max	Units
Forward Current	Continuous Bias	+1	mA
Forward Voltage	Continuous Bias	+1	V
Optical Power	Continuous Wave (CW)	1	mW
Reverse Current	Continuous Bias	-1	mA
Reverse Voltage	Continuous Bias	-(Vb)	V
Reverse Voltage	Pulsed (gated operation)	-(Vb+10)	V

Operation beyond maximum ratings may cause permanent device damage.

TEC SPECIFICATIONS

Parameter	Conditions	Max	Units
TEC Current		0.75	A
TEC Voltage		3.5	V
TEC deltaT	Device case at 298K	77	°C

Thermistor = 1.84K Ω at 298K, 54.55K Ω at 223K

Steinhart-Hart Thermistor Constants: A = 0.8642E-03, B = 3.3085E-04, C = 0.0660E-07



MECHANICAL SPECIFICATIONS

The PGA-308 is packaged in a standard 6 pin TO-8 header with a three stage thermo-electric cooler capable of cooling the APD from package temperature of 27°C to -50°C (223K). A single mode fiber (9/125 μm) pigtail with an FC/PC connector is coupled to the APD. Fiber length: 1.0±0.05m

Dimensions are in mm

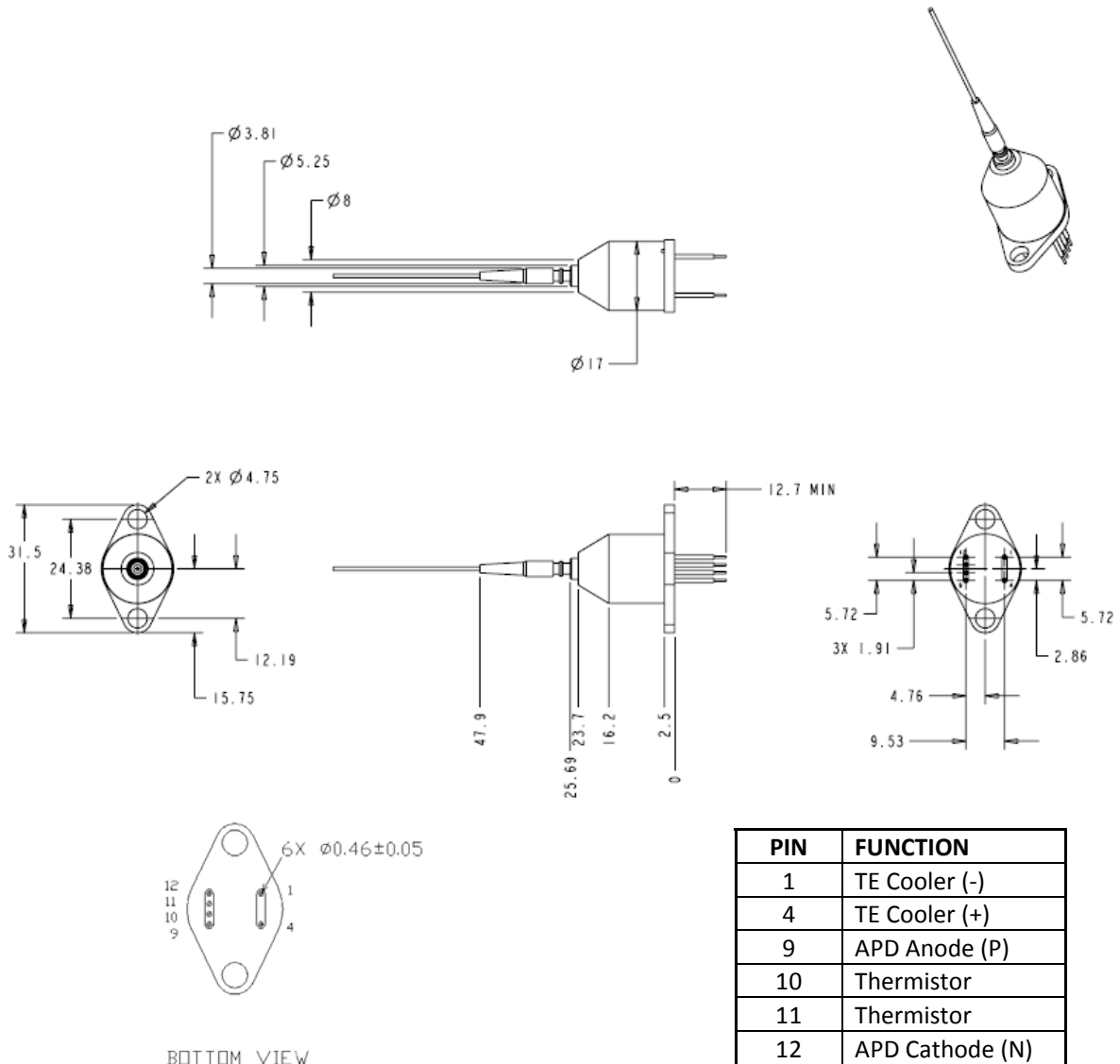

PRODUCT HANDLING

These avalanche photodiodes are sensitive to electrostatic discharge (ESD) and should be handled with appropriate caution, including the use of ESD protective equipment such as grounding straps and anti-static mats.

Princeton Lightwave Inc.
Subject to change without notice

v.4.1 – 09/10/2010

2555 US Route 130 S.
 Cranbury, NJ 08540
 Tel: 609-495-2600
<http://www.princetonlightwave.com>
 © 2010, Princeton Lightwave, Inc.