



PGA-200

Cooled Single Photon Counting Avalanche Photodiode - Discrete

The Princeton Lightwave SPAD is an InGaAs/InP avalanche photodetector designed specifically for single photon counting applications. The device is intended for use at pulsed voltage biases above the breakdown voltage (in the so-called “Geiger mode”) so that a single photon incident on the detector will give rise to a macroscopic current pulse. Combined with appropriate pulse detection circuitry, this device allows for the detection of single photons in the wavelength range from 0.95 to 1.6 μm .

The PLI SPAD described in this datasheet is a back-illuminated device provided in a standard three stage cooled TO-8 can with a window cap.

PERFORMANCE SPECIFICATIONS

Parameter Description	Test Conditions	Specifications			Unit
		Min	Typical	Max	
Linear Mode Parameters ($T_{OP} = 298\text{K}$, all voltages and currents are reverse biased)					
Effective Optical Diameter			25		μm
Breakdown voltage, (V_B)	$I_d = 10 \mu\text{A}$	50	70	90	V
Temperature dependence of V_B, λ	Between 300K and 150K, linear approximation		0.15		%/K
Quantum Efficiency, (QE)	1550 nm, M=1 (Linear mode) 1300 nm, M=1 (Linear mode)		60 75		%
Responsivity, (R)	1550 nm, M=1 (Linear mode) 1300 nm, M=1 (Linear mode)		0.75 0.75		A/W
Total Dark Current, (I_D)	M=10; primarily non-multiplied I_d		0.3		nA
Capacitance, (C)	M=10, 1 MHz		0.25		pF
Geiger Mode Parameters ($T_{OP} = 223\text{K}$)					
Detection Efficiency, (DE)	at DCR maximum	20			%
Dark Count Rate, (DCR)	At DE minimum			75	kHz

ABSOLUTE MAXIMUM RATINGS

Parameter	Conditions	Max	Units
Forward Current	Continuous bias	+1	mA
Forward Voltage	Continuous bias	+1	V
Optical Power	Continuous wave (CW)	1	mW
Reverse Current	Continuous bias	-1	mA
Reverse Voltage	Continuous bias	-(Vb)	V
Reverse Voltage	Pulsed (gated operation)	-(Vb+10)	V

Operation beyond maximum ratings may cause permanent device damage

MECHANICAL SPECIFICATIONS

The TO-8 is a standard 6 pin TO-8 header with a three stage thermo-electric cooler capable of cooling the APD from package temperature of 25°C to -50°C (223K).

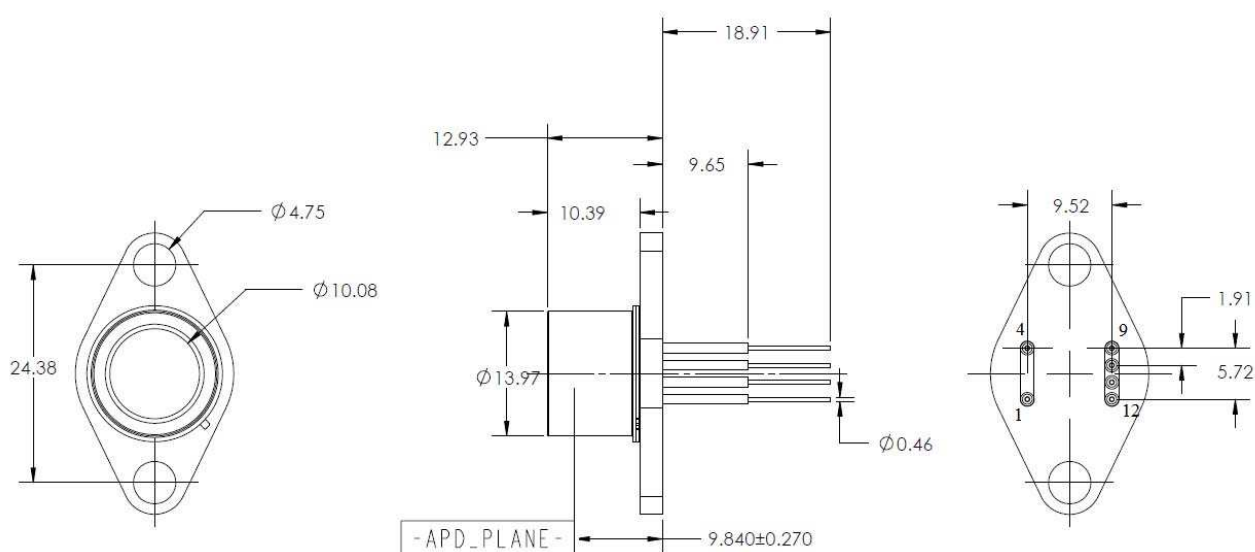

Pin	Function
1.	TE Cooler (-)
4.	TE Cooler (+)
9.	APD Anode (P)
10.	Thermistor
11.	Thermistor
12.	APD Cathode (N)

TEC SPECIFICATIONS

TEC Current 1.50A max

TEC Voltage 1.9V max

TEC ΔT : 77°C, for device case at 298K

Thermistor 2.20K Ω at 298K, 349.12K Ω at 223K

Steinhart-Hart Thermistor Constants: A = 1.6529E-03, B = 2.2102E-04, C = 4.1874E-09

PRODUCT HANDLING

These avalanche photodiodes are sensitive to electrostatic discharge (ESD) and should be handled with appropriate caution, including the use of ESD protective equipment such as grounding straps and anti-static mats.