

## PLA-200 & PLA-280: High Sensitivity Large Area APD Components

### Product Features

- 80 or 200  $\mu\text{m}$  InGaAs APD
- Small form-factor design
- Low dark current
- High reliability, epoxy free, hermetic packaging
- High responsivity in the 0.95-1.65  $\mu\text{m}$  wavelength



*Princeton Lightwave's PLA series APD offers industry-leading performance in terms of dark current, sensitivity and reliability. It leverages PLI's proprietary high performance, planar InP-InGaAs APD device design, and high reliability packaging platforms. The device is designed for operation in the linear mode with voltage bias below breakdown, at typical optical gains of 10-15. The APDs employ a front illuminated design, and packaged in either a standard TO-18 or ceramic sub-mount.*

### Applications

- Laser Radar (LADAR) and Ranging
- Low-level Optical Pulse Discrimination
- Free-space Optical Communication
- Optical Time Domain Reflectometry
- Confocal Microscopy

The component manufacturing is achieved in a high quality, ISO certified facility. Every device undergoes a rigorous quality and reliability regimen, including temperature cycling and high temperature, high bias burn-in. The package construction is organic free with hermetic sealing of the APD. These devices are designed to operate robustly in harsh environment applications.

## PERFORMANCE SPECIFICATIONS

Operating conditions: Case temperature = 23°C

Parameter Description	Test Conditions	Specifications (80 $\mu\text{m}$ )			Specifications (200 $\mu\text{m}$ )			Units
		Min	Typ.	Max	Min	Typ.	Max	
Effective Optical Diameter			80			200		$\mu\text{m}$
Breakdown voltage, $V_b$	$I_d = 10 \mu\text{A}$	55		80	55		80	V
Temp. dependence of $V_b$ , $\Delta V_b/\Delta T$			0.1			0.1		V/°C
Responsivity, R	1550 nm, M=1		0.85			0.85		A/W
Total Dark Current, $I_d$	M=10		3	10		10	50	nA
Dark Noise Current Density, $J_n$	M=10		0.2			0.4		pA/ $\sqrt{\text{Hz}}$
Capacitance, $C^\dagger$	M=10, 1 MHz		0.8	1		1.8	2	pF
Bandwidth, $F_{3dB}$	M=10, 50 $\Omega$ load		1			0.4		GHz
Noise Equivalent Power, NEP	M=10, 1550 nm		0.027			0.050		pW/ $\sqrt{\text{Hz}}$

† Capacitance values include the package capacitance, COC capacitance is 0.15 pF lower

### ABSOLUTE MAXIMUM RATINGS <sup>1</sup>

Parameter	Min	Max	
Storage Temperature	-40	85	C
Operating Temperature	-40	85	C
Forward Current		+1	mA
Forward Voltage		+1	V
Reverse Current		-1	mA
Reverse Voltage		V <sub>b</sub>	V
CW Optical Power <sup>2</sup>		1	mW
TEC Current		2	Amp

<sup>1</sup> Maximum operating ratings indicate operating conditions that the device can sustain without damage for short time intervals. Long term operation under these conditions is not recommended.

<sup>2</sup> Assumes a beam spot > 50 um in diameter

### PRODUCT HANDLING

These APDs are sensitive to electrostatic discharge (ESD) and should be handled with appropriate caution, including the use of ESD protective equipment such as grounding straps and anti-static mats.

### MECHANICAL SPECIFICATIONS: PLA-280, PLA-200 in TO-18

The PLA-080 and PLA-200 are provided in a standard 2-lead TO-18 housing.

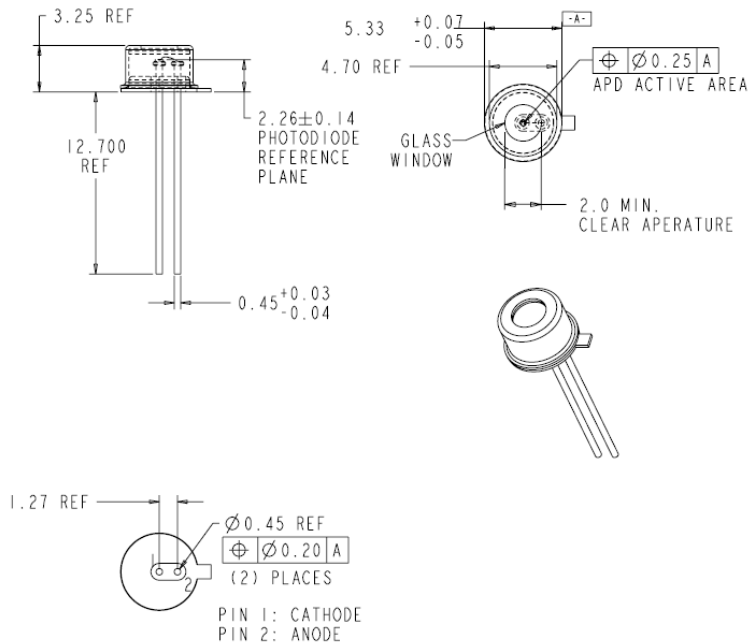

Pin	Function
1	Cathode
2	Anode

PLI's large area APDs can be provided on a customer-supplied or PLI designed ceramic sub-mount.

### ORDERING INFORMATION

**PLA-280:** 80 um APD in TO-18

**PLA-200:** 200 um APD in TO-18