

PRODUCT SPECIFICATION

DATE: 12/04/'03

COSMO ELECTRONICS CORPORATION	REED RELAY: CG1A120000	NO. 50R27004	REV. 1
		SHEET 1 OF 2	

1. OUTSIDE DIMENSION : UNIT (mm)

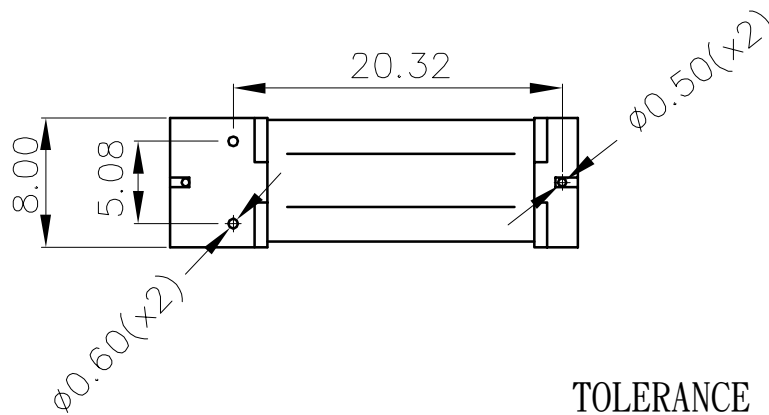
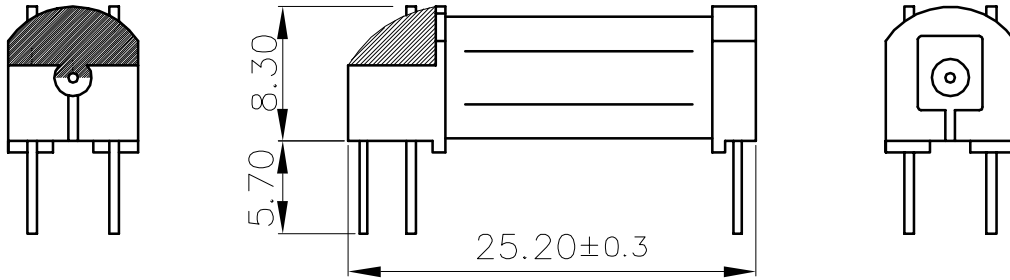

TOLERANCE : $\pm 0.2\text{mm}$

2. SCHEMATIC : TOP VIEW

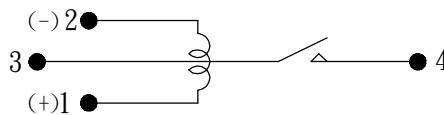

PRODUCT SPECIFICATION

DATE: 12/04/' 03

COSMO ELECTRONICS CORPORATION	REED RELAY: CG1A120000	NO. 50R27004	REV. 1
		SHEET 2 OF 2	

3.0 COIL RATINGS: (AT 20°C)

3.1	Coil resistance	1050 Ω ($\pm 10\%$)
3.2	Nominal coil current	12 VDC
3.3	Maximun Continuous voltage	19.2 VDC
3.4	Must operate	8.4 VDC
3.5	Must release	1.2 VDC
3.6	Rated current	11.4 mA

4.0 ELECTRONICAL CHARACTERISTICS:

4.1	Contact resistance	150 $m\Omega$ (max)
4.2	Operate time	1.0 ms (max)
4.3	Bounce time	0.5 ms (max)
4.4	Release time	0.5 ms (max)
4.5	Insulation resistance (100 VDC open contact)	$10^9 \Omega$ (min)
	(between coil & contact 500VDC)	$10^8 \Omega$ (min)
4.6	Power	10 VA (max)
4.7	Switching voltage	100 VDC (max)
4.8	Switching current	0.5 A (max)
4.9	Carry current	1.0 A (max)
4.10	Breakdown voltage (across open contact)	200 VDC (1sec)
	(between coil & contact)	3000 VDC (1sec)
4.11	Life expectancy (6V, 10mA)	10^7
4.12	Temperature Range	-30 to 60°C
4.13	Humidity Range	-45 to 85% RH.
4.14	Shock Endurance	100G (Min)
4.15	Shock Error Operation	13G (Min)
4.16	Vibration Endurance	10 to 55HZ Double Amplitude 1.5mm
4.17	Vibration Error Operation	10 to 55HZ Double Amplitude 1.5mm
4.18	Minimun permissible load	1VDC, 1mA