

PRODUCT SPECIFICATION

DATE: 05/11/94'

KUAN HSI ELECTRONICS CO.,LTD.	Reed Relay : D1B121000	NO. 50R02008	REV.
		SHEET 1 OF 2	1

1. OUTSIDE DIMENSION : UNIT (mm)

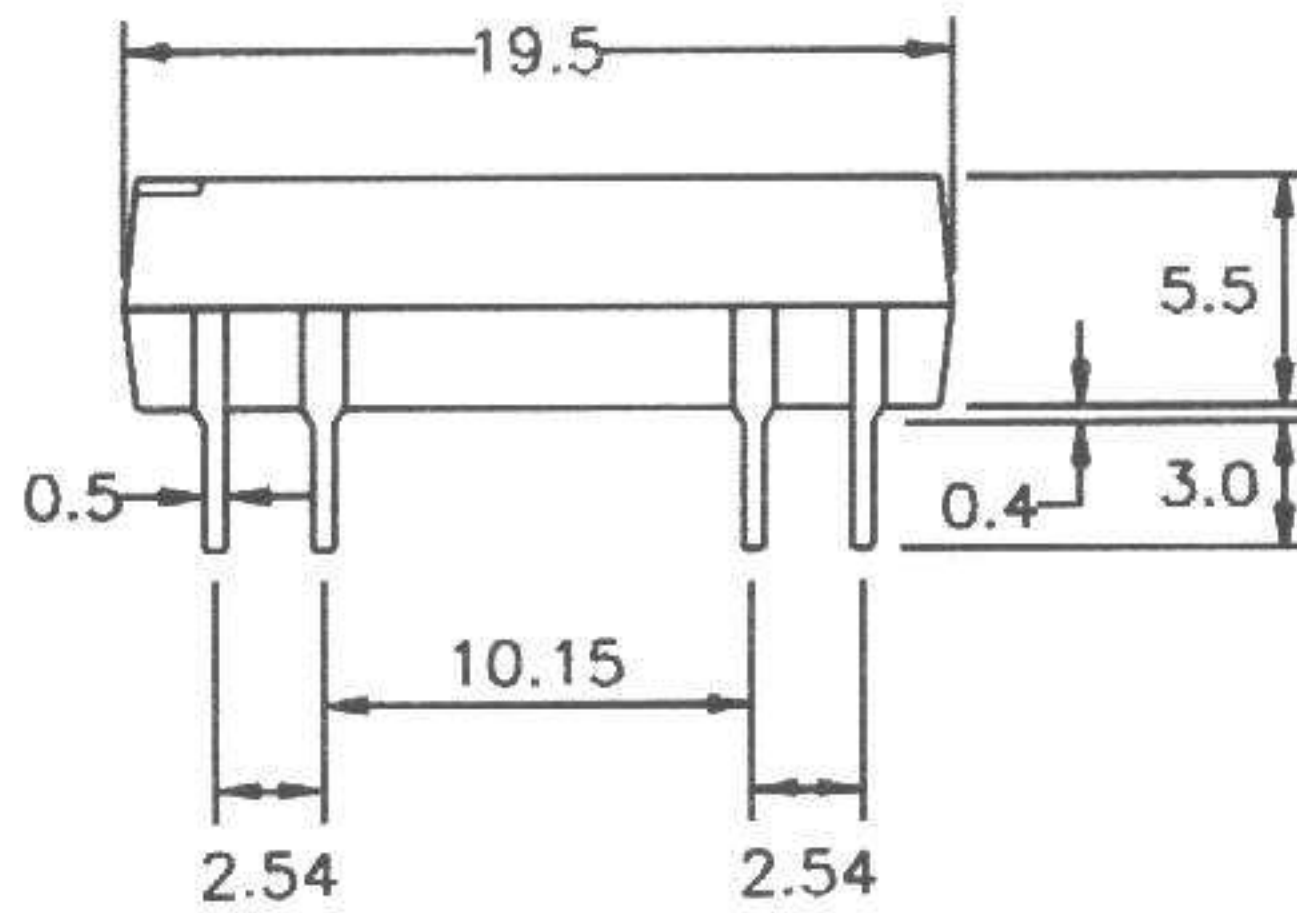
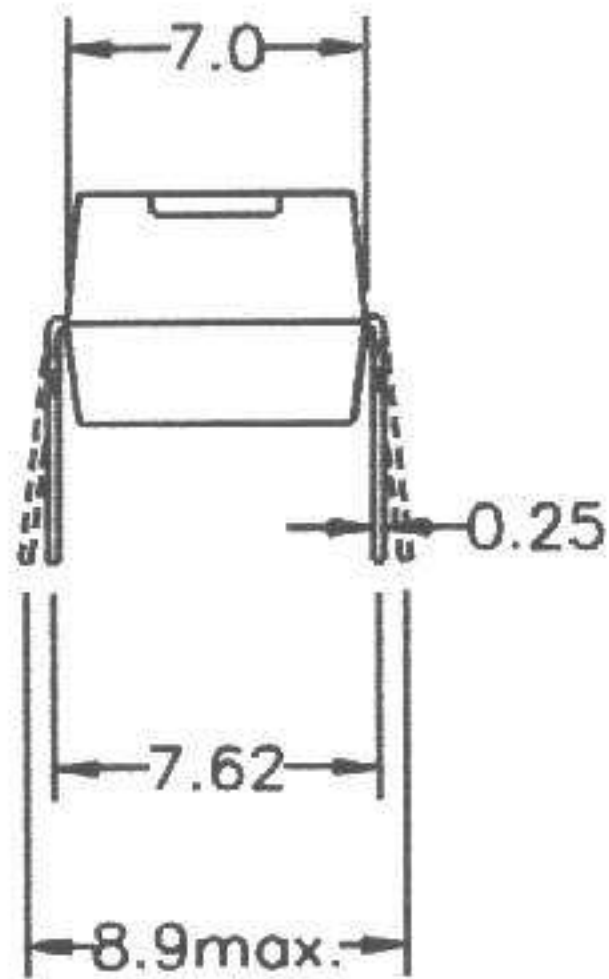
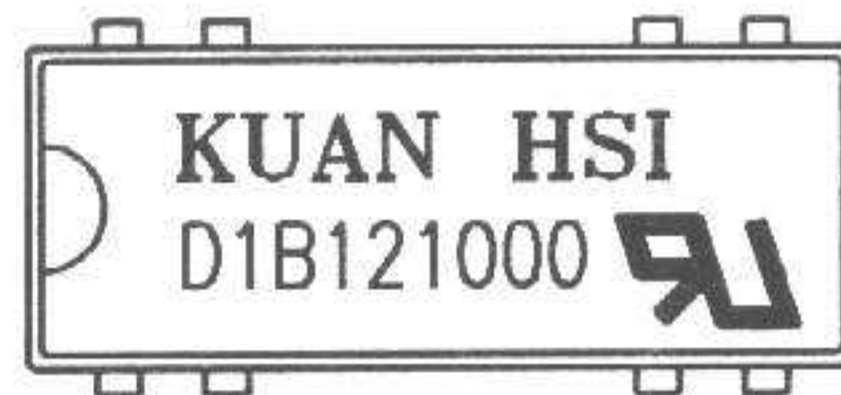

TOLERANCE : $\pm 0.1\text{mm}$

2. SCHEMATIC : TOP VIEW

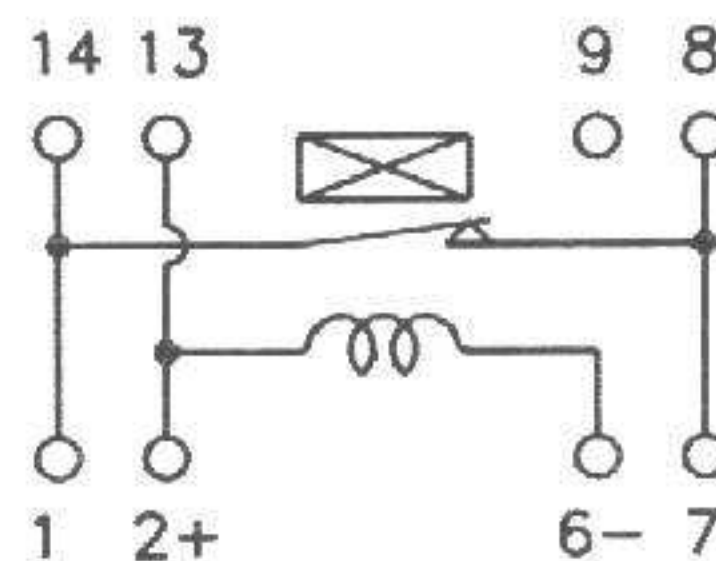

ISSUE <i>Jacky Wong</i> 5-11-1994	CHECK <i>Alan Lui</i> 5-12-1994	APPROVED <i>[Signature]</i> 5-13-1994
--------------------------------------	------------------------------------	--

PRODUCT SPECIFICATION

DATE: 05/11/94'

KUAN HSI ELECTRONICS CO.,LTD.	Reed Relay : D1B121000	NO. 50R02008	REV.
		SHEET 2 OF 2	1

3.0 COIL RATINGS: (AT 20°C)

3.1	Coil resistance	1000	(Ω ± 10%)
3.2	Nominal coil voltage	12	(VDC)
3.3	Maximun Continuous voltage	15	(VDC)
3.4	Must operate	9	(VDC)
3.5	Must release	1.2	(VDC)
3.6	Rated current	12	(mA)

4.0 ELECTRONICAL CHARACTERISTICS :

4.1	Contact resistance	100	(mΩ max)
4.2	Operate time	0.5	(mS max)
4.3	Bounce time	0.5	(mS max)
4.4	Release time	0.2	(mS max)
4.5	Insulation resistance (100 VDC open contact)	10 ¹¹	(Ω min)
4.6	Power	10	(VA max)
4.7	Switching voltage	200	(VDC max)
4.8	Switching current	0.5	(A max)
4.9	Carry current	1.0	(A max)
4.10	Breakdown voltage (across open contact)	250	(VDC min)
	(between coil & contact)	500	(VDC min)
4.11	Life expectancy (signal level)	10 ⁸	
4.12	Operating temp.	-40	to 85°C
4.13	Storage temp.	-50	to 125°C
4.14	Resonant frequency	3.5	(KHZ)
4.15	Vibration (10 - 2000 HZ)	20	(g max)
4.16	Minimum permissible load	100	mVDC 10uA

ISSUE <i>Jacky Wang</i> 5-11-1994	CHECK <i>Alan Fung</i> 5-12-1994	APPROVED <i>[Signature]</i> 5-13-1994
--------------------------------------	-------------------------------------	--