

# PRODUCT SPECIFICATION

DATE : 09/01/2006

<b>cosmo</b> ELECTRONICS CORPORATION	SOLID STATE RELAY - MOSFET OUTPUT	NO.60M21005	VER. 1
	<b>KAQW412</b>	SHEET 1 OF 7	

## ● OUTSIDE DIMENSION :

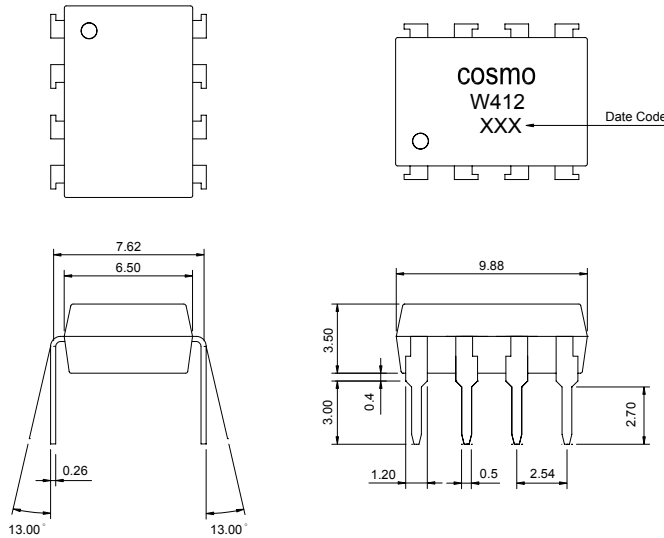

Unit : mm  
Tolerance : ±0.2mm

## ● Operate / Reverse time

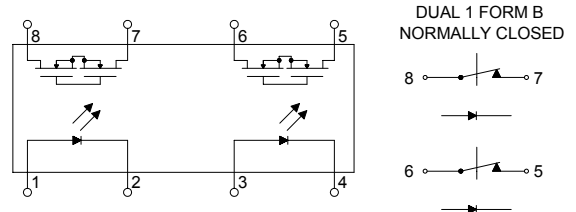
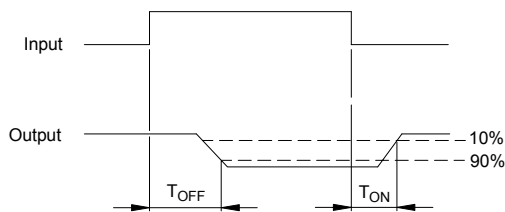

## ● Absolute Maximum Ratings

(Ta=25°C)

Emitter ( Input )		Detector ( Output )	
Reverse Voltage .....	5.0V	Output Breakdown Voltage .....	± 60V
Continuous Forward Current .....	50mA	Continuous Load Current .....	± 200mA
Peak Forward Current .....	1A	Power Dissipation .....	500mW
Power Dissipation .....	100mW		
Derate Linearly from 25°C .....	1.3mW/°C		
General Characteristics			
Isolation Test Voltage .....	5000VACrms	Storage Temperature Range .....	-40°C to +125°C
Isolation Resistance		Operating Temperature Range ...	-40°C to +85°C
Viso=500V , Ta=25°C .....	≥ 10 <sup>10</sup> Ω	Junction Temperature .....	100°C
Total Power Dissipation .....	550mW	Soldering Temperature ,	
Derate Linearly from 25°C .....	2.5mW/°C	2mm from case , 10 sec .....	260°C

# PRODUCT SPECIFICATION

DATE : 09/01/2006

<b>cosmo</b> ELECTRONICS CORPORATION	SOLID STATE RELAY - MOSFET OUTPUT	NO.60M21005	VER.
	<b>KAQW412</b>	SHEET 2 OF 7	1

## ● Electro-optical Characteristics

(Ta=25°C)

Parameter		Symbol	Conditions	Min.	Typ.	Max.	Unit.
Emitter ( Input )							
Forward Voltage		$V_F$	$I_F=10\text{mA}$		1.2	1.5	V
Operation Input Current		$I_{F\text{OFF}}$	$V_L=\pm 20\text{V}, I_L \leq 5\mu\text{A}$			5	mA
Recovery Input Current		$I_{F\text{ON}}$	$V_L=\pm 20\text{V}, I_L=100\text{mA}, t=10\text{ms}$	0.2			mA
Detector ( Output )							
Output Breakdown Voltage		$V_B$	$I_B=50\mu\text{A}$	60			V
Output Off-State Leakage		$I_{T\text{OFF}}$	$V_T=100\text{V}, I_F=10\text{mA}$		0.2	2	$\mu\text{A}$
I/O Capacitance		$C_{\text{ISO}}$	$I_F=0, f=1\text{MHz}$		6		pF
ON Resistance	Connection	A	$I_L=100\text{mA}, I_F=0\text{mA}$		2.5	5	$\Omega$
		B			1.25	2.5	
		C			0.63	1.25	
Operate Time		$T_{\text{OFF}}$	$I_F=10\text{mA}, V_L=\pm 20\text{V}$ $t=10\text{ms}, I_L=\pm 100\text{mA}$		0.6	1.5	ms
Reverse Time		$T_{\text{ON}}$			0.3	1.5	ms

## ● MOS Relay Schematic and Wiring Diagrams

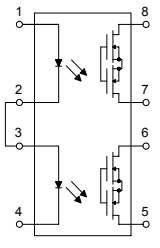
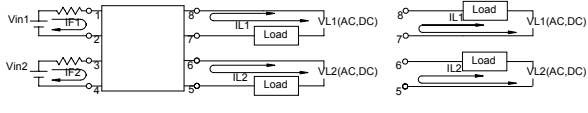
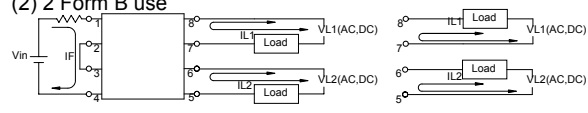
Schematic	Output configuration	Load	Connection	Wiring Diagrams
	2b	AC/DC	-	<p>(1) Two independent 1 Form B use</p>  <p>(2) 2 Form B use</p> 

# PRODUCT SPECIFICATION

DATE : 09/01/2006

**cosmo**  
ELECTRONICS CORPORATION

SOLID STATE RELAY - MOSFET OUTPUT  
**KAQW412**

NO.60M21005  
SHEET 3 OF 7

VER.  
1

## ● Data Curve

Load current vs. ambient temperature  
Allowable ambient temperature :  
-40°C to +85°C

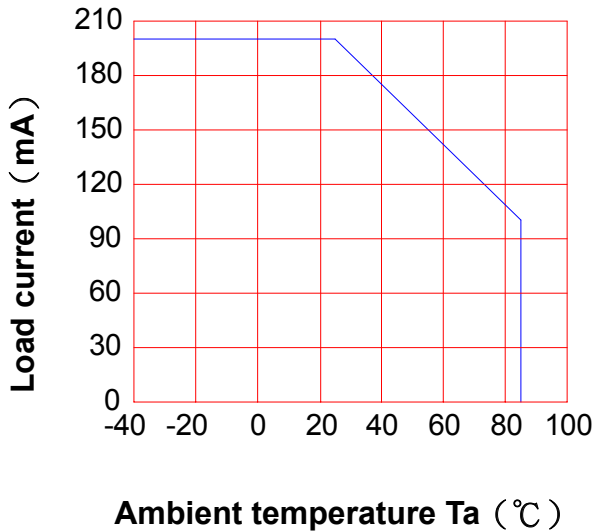

On resistance vs. ambient temperature  
across terminals 5 , 7 and 6 , 8 pin  
LED current : 5mA  
Continuous load current : 200mA (DC)

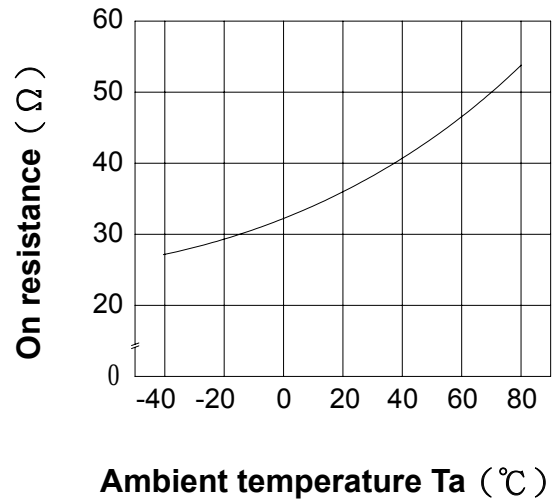

Operate (OFF) time vs. ambient temperature  
Load voltage 60V (DC)  
LED current : 5mA  
Continuous load current : 200mA (DC)

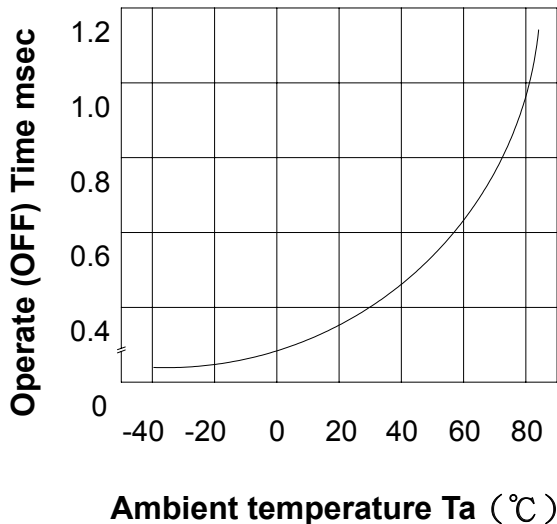

Reverse (ON) time vs. ambient temperature  
Load voltage 60V (DC)  
LED current : 5mA  
Continuous load current : 200mA (DC)

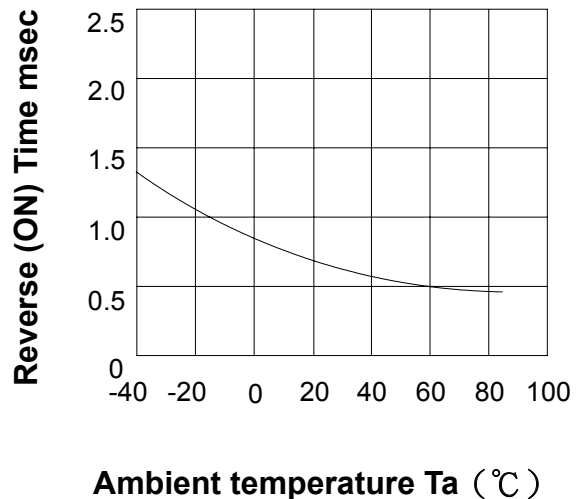

# PRODUCT SPECIFICATION

DATE : 09/01/2006

**cosmo**  
ELECTRONICS CORPORATION

SOLID STATE RELAY - MOSFET OUTPUT  
**KAQW412**

NO.60M21005  
SHEET 4 OF 7

VER.  
1

LED operate (OFF) current vs.  
ambient temperature

Load Voltage : 60V (DC)

Continuous load current : 200mA (DC)

LED operate (OFF) current (mA)

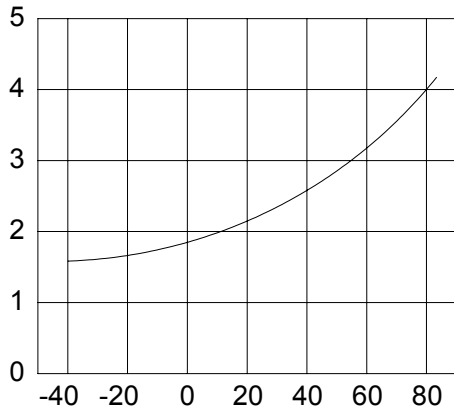

Ambient temperature Ta (°C)

LED Reverse (ON) current vs.  
ambient temperature

Load Voltage : 60V (DC)

Continuous load current : 200mA (DC)

LED Reverse (ON) current (mA)

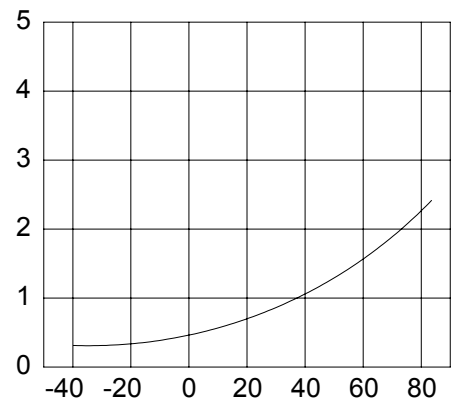

Ambient temperature Ta (°C)

LED dropout voltage vs.  
ambient temperature

LED current : 5 to 50mA

LED dropout voltage (V)

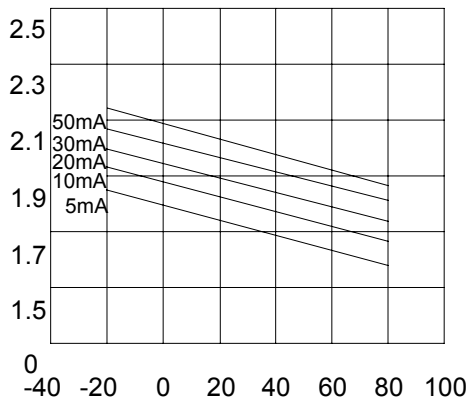

Ambient temperature Ta (°C)

Voltage vs. current characteristics of  
output at MOSFET portion

Measured portion : across terminals

5, 7 and 6, 8 pin

Ambient temperature : 25°C

Voltage VS. Current  
Characteristics

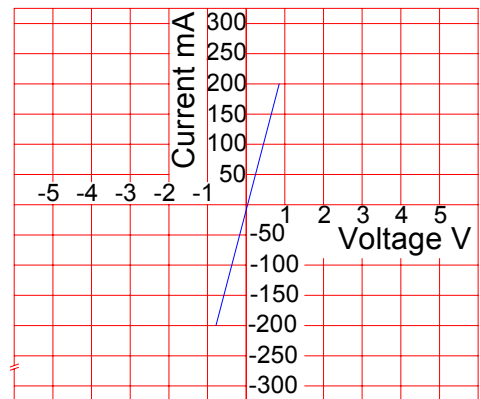

# PRODUCT SPECIFICATION

DATE : 09/01/2006

**cosmo**  
ELECTRONICS CORPORATION

SOLID STATE RELAY - MOSFET OUTPUT  
**KAQW412**

NO.60M21005  
SHEET 5 OF 7

VER.  
1

**LED forward current vs. Operate (OFF) time across terminals 5 , 7 and 6 , 8 pin**  
Load voltage : 60V (DC)  
Continuous load current : 200mA (DC)  
Ambient temperature : 25°C

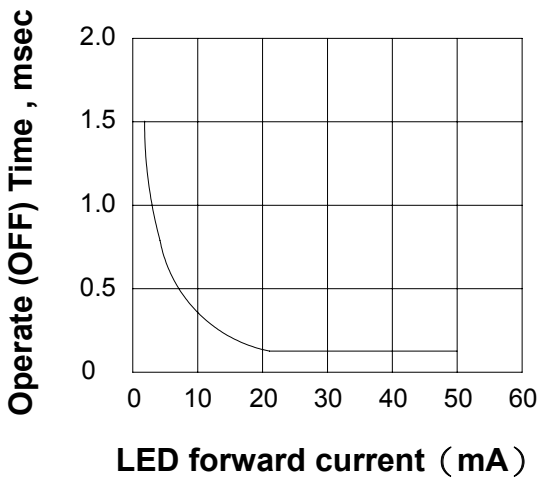

**Off state leakage current**  
Across terminals 5 , 7 and 6 , 8 pin  
Ambient temperature : 25°C

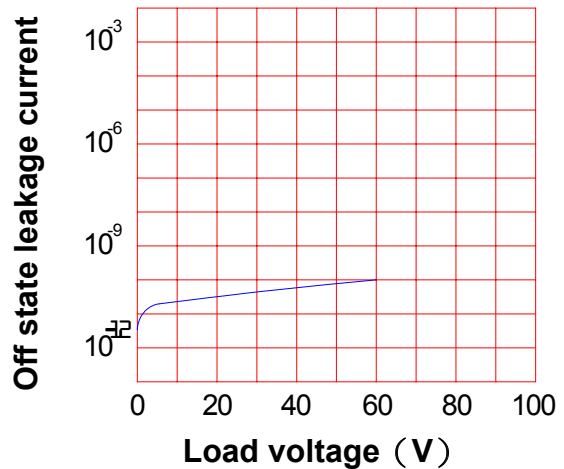

**LED forward current vs. Reverse (ON) time**  
Across terminals 5 , 7 and 6 , 8 pin  
Load voltage : 60V (DC)  
Continuous load current : 130mA (DC)  
Ambient temperature : 25°C

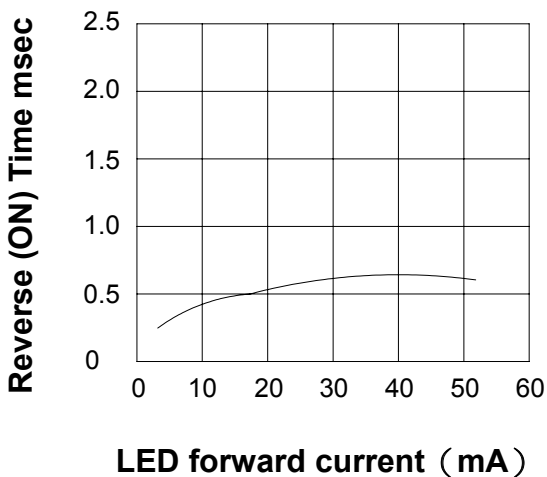

**Applied voltage vs. output capacitance**  
Across terminals 5 , 7 and 6 , 8 pin  
Frequency : 1MHz  
Ambient temperature : 25°C

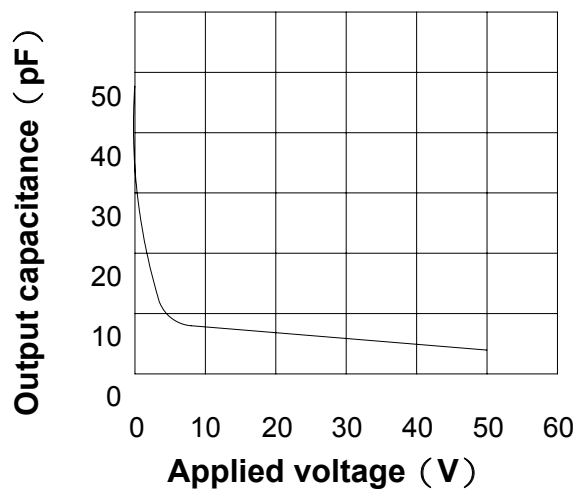

# PRODUCT SPECIFICATION

DATE : 09/01/2006

<b>cosmo</b> ELECTRONICS CORPORATION	SOLID STATE RELAY - MOSFET OUTPUT	NO.60M21005	VER. 1
	<b>KAQW412</b>	SHEET 6 OF 7	

## ● USING METHODS

Examples of resistance value to control LED forward current ( $I_F$ )

SSR-MOSFET OUTPUT

( $I_F=5\text{mA}$ )

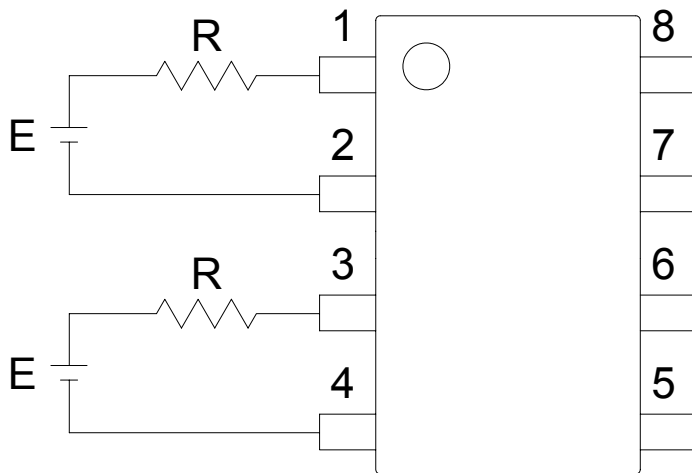

E	R
3.3V	Approx. 330 $\Omega$
5V	Approx. 640 $\Omega$
12V	Approx. 1.9K $\Omega$
15V	Approx. 2.5K $\Omega$
24V	Approx. 4.1K $\Omega$

- (1) LED forward current must be more than 5mA , at E min.
- (2) LED forward current must be less than 50mA , at E max.

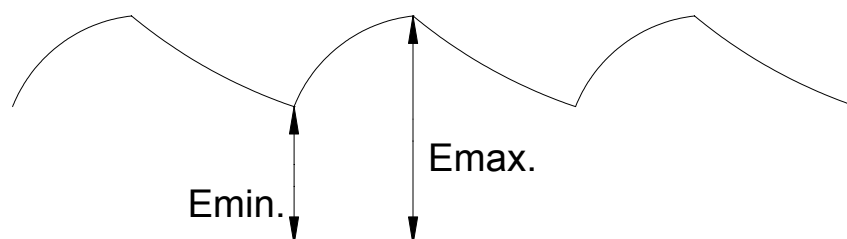

# PRODUCT SPECIFICATION

DATE : 09/01/2006

<b>cosmo</b> ELECTRONICS CORPORATION	SOLID STATE RELAY - MOSFET OUTPUT <b>KAQW412</b>	NO.60M21005	VER. 1
		SHEET 7 OF 7	

## ● USING METHODS

Regulate the spike voltage generated on the inductive load as follows :

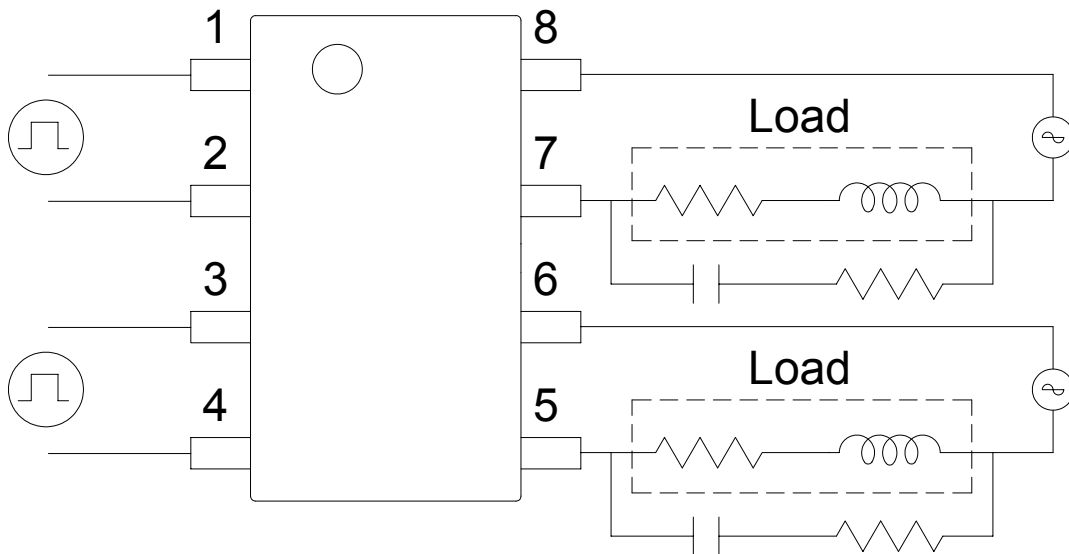
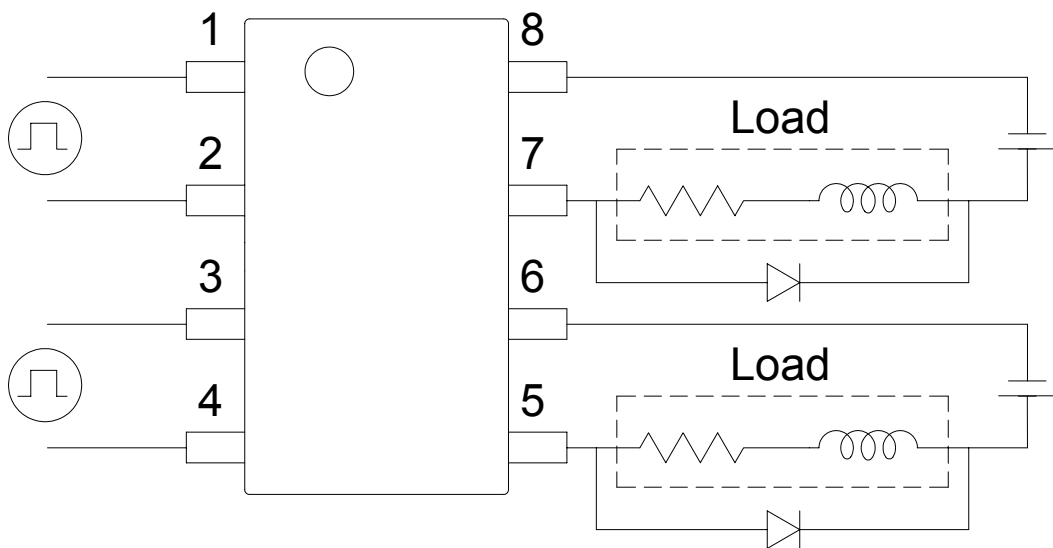

R-C Snubber