

APPROVAL SHEET

DATE: 02/22/2010

cosmo ELECTRONICS CORPORATION	Photolink : KPLR2500M5X/6X/7X/8X	NO.60F11002	REV.
		SHEET 1 OF 4	2

FIBER OPTIC Receiver Module

Features

- TTL interface compatible.
- 25Mbps data rate(NRZ Signal).
- Directly connectable to demodulation IC.
- Supply voltage 3.3V/ 5V equipment.

Applications

- Audio equipment .
- DVD,CD,MD player .
- Automobile.
- Sound card.
- Set top box.
- PC,Notebook.

Outline Dimensions

(Unit:mm)

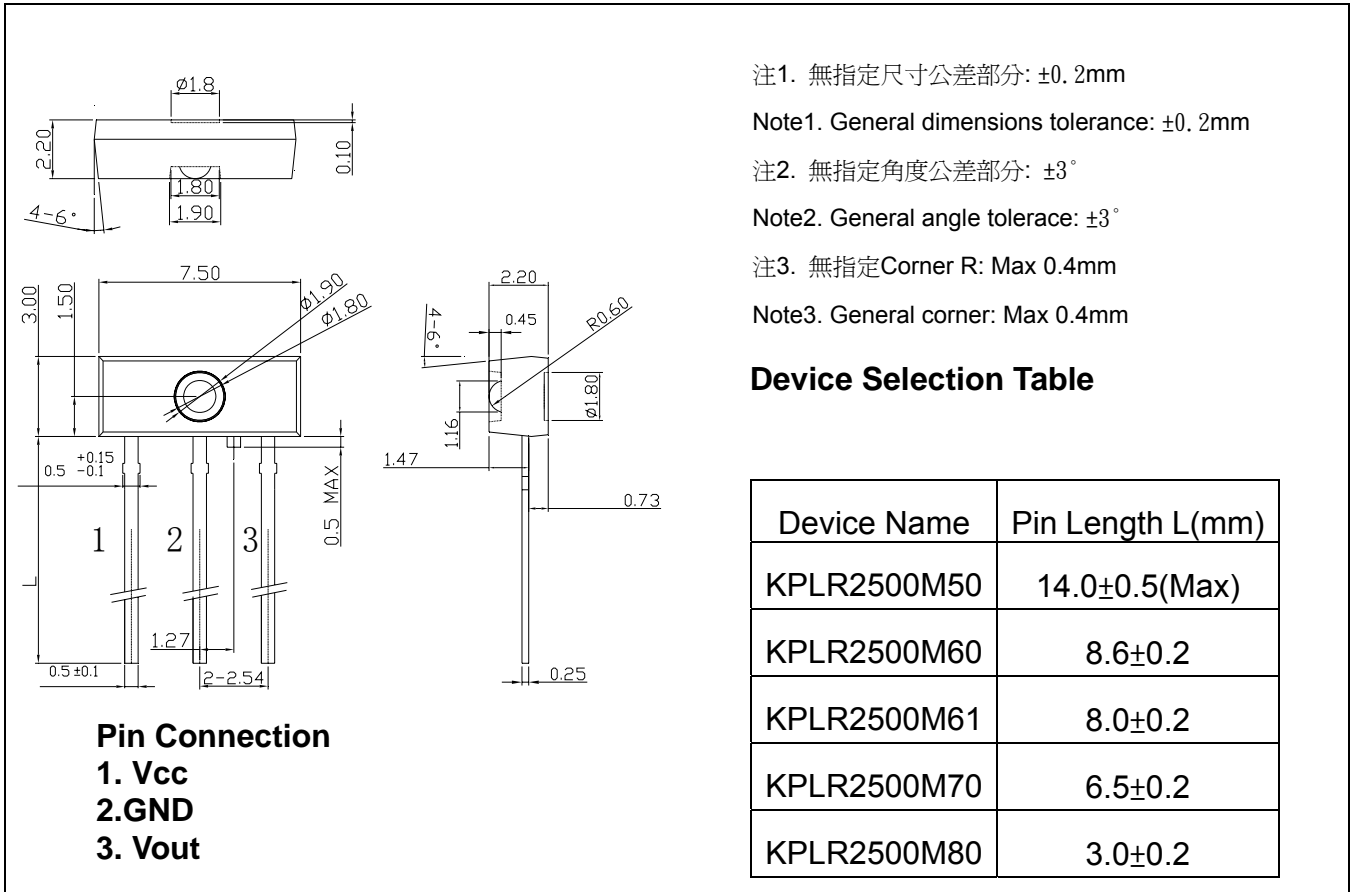

APPROVAL SHEET

DATE: 02/22/2010

cosmo ELECTRONICS CORPORATION	Photolink : KPLR2500M5X/6X/7X/8X	NO.60F11002	REV.
		SHEET 2 OF 4	2

1. Maximum Ratings (Ta=25°C, Vcc=3.3V/5V)

Parameter	Symbol	Rating	Unit
Storage Temperature	T _{stg}	-40~85	°C
Operating Temperature	T _{opr}	-20~70	°C
Supply Voltage	V _{CC}	-0.5~7	V
Input Voltage	V _{IN}	-0.5~V _{CC} +0.5	V
Soldering Temperature	T _{sol}	260 ^(Note 1)	°C

Note 1 : Soldering time \leq 10 seconds (At a distance of 1 mm from the package) .

2. Recommended Operating Conditions (Ta=25°C, Vcc=3.3V/5V)

Parameter	Symbol	Min	Typ.	Max	Unit
Supply Voltage	V _{CC}	2.7	-	5.25	V
Operating transfer rate	T	0.1	-	25	Mbps
Input optical power level	PI	-27	-	-14.5	dBm

3. Electrical and Optical Characteristics :Receiver (Ta=25°C, Vcc=3.3V/5V)

Parameter	Symbol	Condition	Min	Typ.	Max	Unit
Operating transfer rate	T	NRZ Signal ^(Note 2)	0.1	-	25	Mb/s
Operating voltage	V _{CC}		2.7	3.0	5.25	V
Optical Input Sensitivity ^(Note 3)	PI		-27	-	-14.5	dBm
Peak Emission Wavelength	λ_p		-	650	-	nm
Dissipation Current	I _{CC}	Refer to Fig.(1)	-	-	13	mA
High Level Output Voltage	V _{OH}	Refer to Fig.(2)	2.1	-	-	V
Low Level Output Voltage	V _{OL}	Refer to Fig.(2)	-	-	0.4	V
Rise time	t _r	Refer to Fig.(2)	-	-	20	ns
Fall time	t _f	Refer to Fig.(2)	-	-	20	ns
Low->High Propagation delay time	t _{PLH}	Refer to Fig.(2)	-	-	100	ns
High -> Low Propagation delay time	t _{PHL}	Refer to Fig.(2)	-	-	100	ns
Pulse Width Distortion	Δt_w	Refer to Fig.(2)	-20	-	20	ns
Jitter Time	Δt_j	Refer to Fig.(3)	-	-	20	ns

Note 2 : LED is ON when input signal is high, and OFF when it is low.

The duty factor must be maintained between 25 to 75%.

Note 3 : Measure with a standard optical fiber, peak value.

APPROVAL SHEET

DATE: 02/22/2010

cosmo ELECTRONICS CORPORATION	Photolink : KPLR2500M5X/6X/7X/8X	NO.60F11002 SHEET 3 OF 4	REV. 2

4. Measuring method

(1). Measuring Supply Current

	Input test Conditions	Measuring method
Supply Voltage	Vcc=3.0V	DC Average current
Fiber coupling light output	Pc=-14.5dBm	
Standard transmitter input signal	25Mbps NRZ	

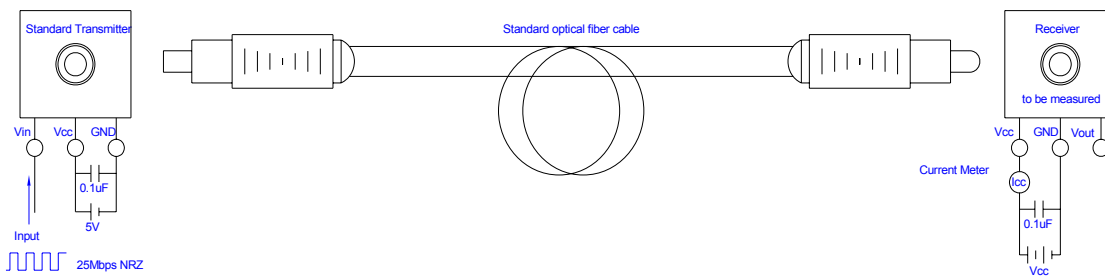

(2). Measuring method of Output Voltage and Pulse response

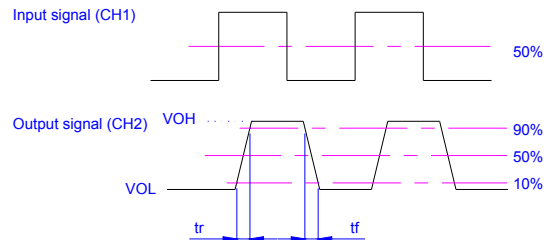
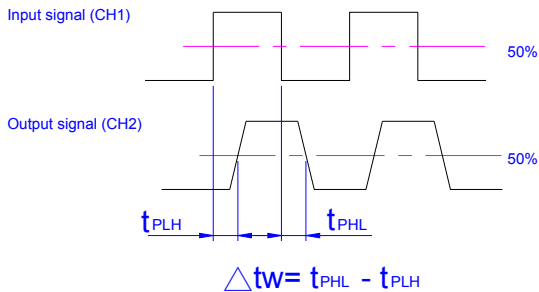
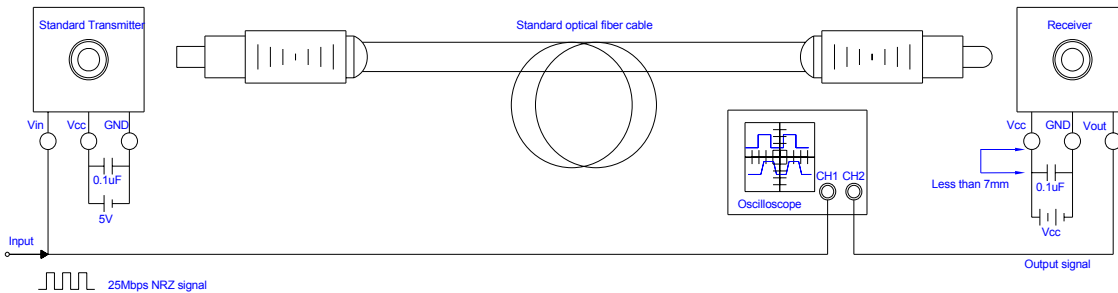

APPROVAL SHEET

DATE: 02/22/2010

cosmo ELECTRONICS CORPORATION	Photolink : KPLR2500M5X/6X/7X/8X	NO.60F11002	REV. 2
		SHEET 4 OF 4	

(3).Measuring method of Jitter

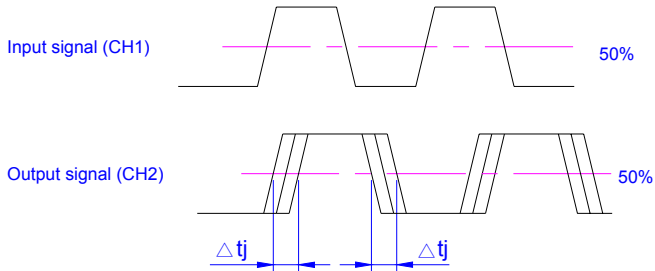
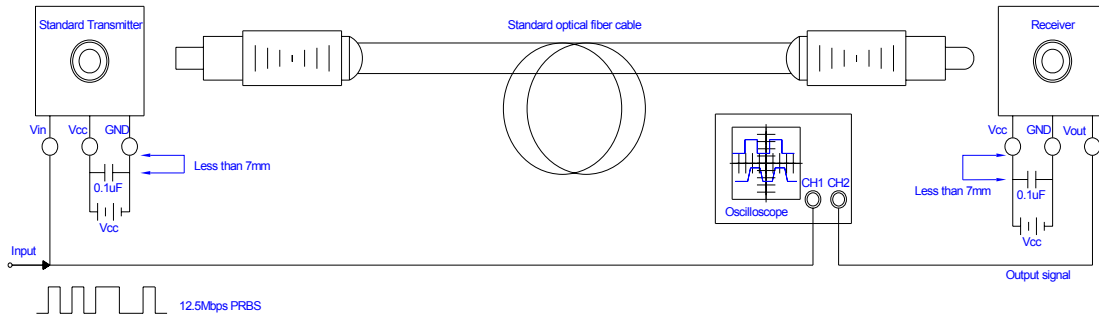

5.Recommended PCB Layout

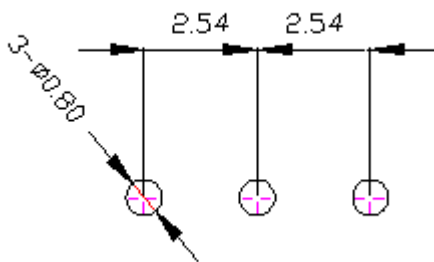

- Notes:**
- 1.Unit:mm
 - 2.tolerance:±0.3mm