

● Description

The KPC6N135 series consist of a LED optically coupled to an OPIC chip. It is a high-speed digital output type photocoupler designed specifically for low circuit current. And it is packaged in a 8 pin DIP package and available in wide-lead spacing and SMD option.

● Schematic

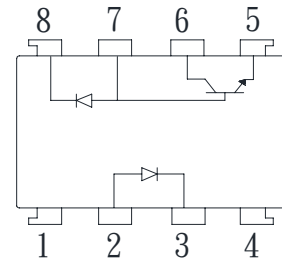

1. N.C.	5. GND
2. Anode	6. Vo
3. Cathode	7. V _B
4. N.C.	8. V _{CC}

● Features

1. Pb free and RoHS compliant
2. High speed response t_{PHL} , t_{PLH} (Max. 1.5us at $R_L=4.1K\Omega$)
3. High common mode rejection voltage (CM_H : TYP. 1KV/us)
4. Standard dual-in-line package
5. Agency Approvals:
 - UL1577 / CUL C22.2 No.1 & NTC No.5, File No. E169586
 - VDE EN 60747, File No. 40006080
 - FIMKO EN60065, File No. FI25798
 - FIMKO EN60950, File No. FI25798

● Applications

- Computers, measuring instruments, control equipment
- High speed line receivers, high speed logic
- Telephone sets
- Signal transmission between circuits of different potentials and impedances

● **Outside Dimension**

Unit : mm

1. Dual-in-line type

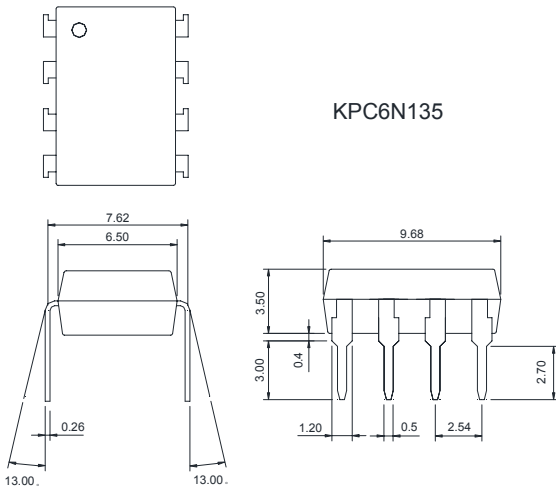

2. Surface mount type

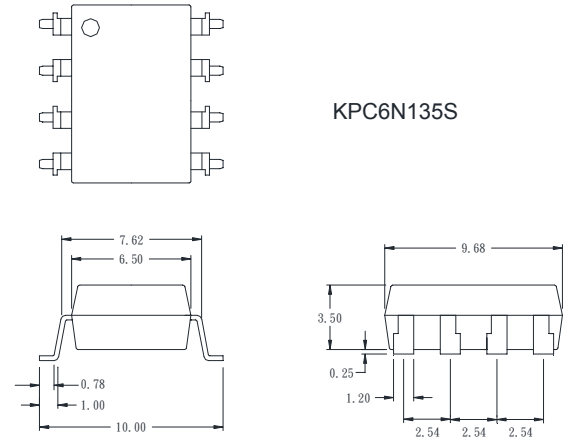

3. Long creepage distance type

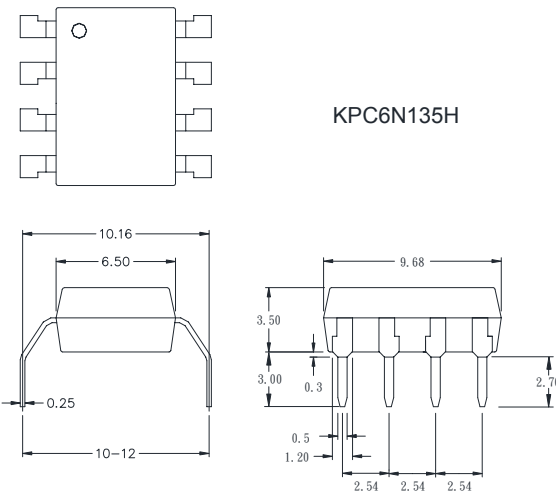

4. Long creepage distance for surface mount type

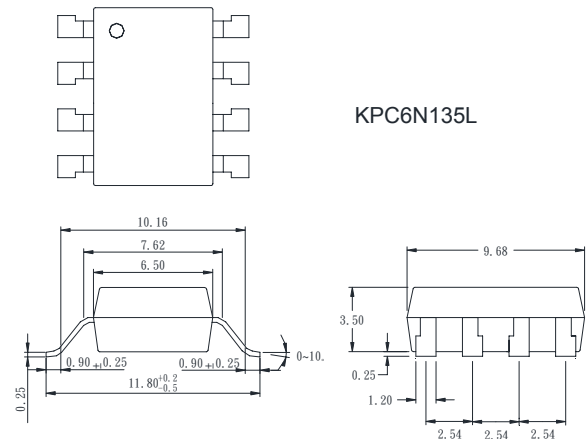

TOLERANCE : ± 0.2 mm

● **Device Marking**

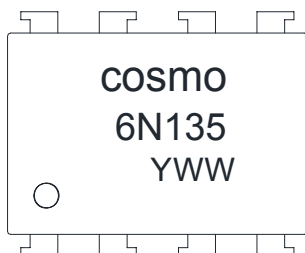

Notes:

COSMO
6N135
YWW Y: Year code / WW: Week code

● Absolute Maximum Ratings

(Ta = 25°C)

Parameter		Symbol	Rating	Unit
Input	Forward current	I_F	25	mA
	*1 Peak forward current	I_F	50	mA
	*2 Peak transient forward current	I_{FM}	1	A
	Reverse voltage	V_R	5	V
	Power dissipation	P	45	mW
Output	Supply voltage	V_{CC}	-0.5 to 15	V
	Output voltage	V_O	-0.5 to 15	V
	Emitter-base reverse with stand voltage (Pin5 to 7)	V_{EBO}	5	V
	Average output current	I_O	8	mA
	Peak output current	I_{OP}	16	mA
	Base current (Pin7)	I_B	5	mA
	Power dissipation	P_O	100	mW
	*3 Isolation voltage 1 minute	V_{iso}	5000	Vrms
Operating temperature		T_{opr}	-55 to +100	°C
Storage temperature		T_{stg}	-55 to +125	°C
*4 Soldering temperature 10 seconds		T_{sol}	260	°C

*1 50% duty cycle, Pulse width : 1mS

Decreases at the rate of 1.6mA/°C if the external temperature is 70°C or more.

*2 Pulse width ≤ 1uS, 300pulse/sec

*3 40 to 60% RH, AC for 1 minute

*4 For 10 seconds

● Electrical Characteristics

(Ta = 25°C)

Parameter	Symbol	Conditions	Min.	Typ.	Max.	Unit
*5 Current transfer ratio	CTR(1)	Ta=25°C, $I_F=16mA$ $V_O=0.4V$, $V_{CC}=4.5V$	7	40	-	%
	CTR(2)	$I_F=16mA$ $V_O=0.5V$, $V_{CC}=4.5V$	5	43	-	%
Logic (0) output voltage	V_{OL}	*6 $V_{CC}=4.5V$, $I_F=16mA$	-	0.1	0.4	V
Logic (1) output current	$I_{OH}(1)$	Ta=25°C, $I_F=0$ $V_O=V_{CC}=5.5V$	-	3.0	500	nA
	$I_{OH}(2)$	Ta=25°C, $I_F=0$ $V_O=V_{CC}=15V$	-	0.01	1.0	uA
	$I_{OH}(3)$	$V_{CC}=V_O=15V$, $I_F=0$	-	-	50	uA
Logic (0) supply current	I_{CCL}	$I_F=16mA$ $V_O=open$, $V_{CC}=15V$	-	200	-	uA
Logic (1) supply current	$I_{CCH}(1)$	Ta=25°C, $I_O=0$ $V_F=open$, $V_{CC}=15V$	-	0.02	1.0	uA
	$I_{CCH}(2)$	$I_O=0$ $V_O=open$, $V_{CC}=15V$	-	-	2.0	uA
Input forward voltage	V_F	Ta=25°C, $I_F=16mA$	-	1.7	1.95	V
Input forward voltage temperature coefficient	$\Delta V_F/\Delta Ta$	$I_F=16mA$	-	-1.9	-	mV/°C
Input reverse voltage	BV_R	Ta=25°C, $I_R=10uA$	5.0	-	-	V
Input capacitance	C_{IN}	$V_F=0$, f=1MHz	-	60	-	pF
*7 Leak current (input-output)	I_{I-O}	Ta=25°C, 45%RH $V_{I-O}=3KVDC$, t=5s	-	-	1.0	uA
*7 Isolation resistance (input-output)	R_{I-O}	$V_{I-O}=500VDC$	-	10^{12}	-	Ω
*7 Capacitance (input-output)	C_{I-O}	f=1MHz	-	0.6	-	pF
Transistor current amplification factor	h_{FE}	$V_O=5V$, $I_O=3mA$	-	70	-	

*5 Current transfer ratio is the ratio of input current and output current expressed in %

*6 $I_O=1.1mA$

*7 Measured as 2-pin element (Short 1, 2, 3, 4 and 5, 6, 7, 8)

● Switching Characteristics

($T_a=25^\circ\text{C}$, $V_{CC}=5\text{V}$, $I_F=16\text{mA}$ $T_a = 25^\circ\text{C}$)

Parameter	Symbol	Conditions	Min.	Typ.	Max.	Unit
*8 Propagation delay time *9 Output (1) → (0)	t_{PHL}	$R_L=4.1\text{K}\Omega$	-	0.3	1.5	μs
*8 Propagation delay time *9 Output (0) → (1)	t_{PLH}	$R_L=4.1\text{K}\Omega$	-	0.4	1.5	μs
*10 Instantaneous common mode rejection voltage *11 "Output (1)"	CM_H	$I_F=0$, $V_{CM}=10V_{P-P}$	-	1000	-	$\text{V}/\mu\text{s}$
*10 Instantaneous common mode rejection voltage *11 "Output (0)"	CM_L	$I_F=16\text{mA}$, $V_{CM}=10V_{P-P}$	-	-1000	-	$\text{V}/\mu\text{s}$
*12 Bandwidth	BW	$R_L=100\Omega$	-	2.0	-	MHz

*8 $R_L=4.1\text{K}\Omega$ is equivalent to one LSTTL and $6.1\text{K}\Omega$ pull-up resistor.

*10 Instantaneous common mode rejection voltage "output (1)" represents a common mode voltage variation that can hold the output above (1) level ($V_o > 2.0\text{V}$)
 Instantaneous common mode rejection voltage "output (0)" represents a common mode voltage variation that can hold the output above (0) level ($V_o < 0.8\text{V}$)

*12 Bandwidth represents a point where AC input goes down by 3dB.

*9 Test Circuit Propagation Delay Time

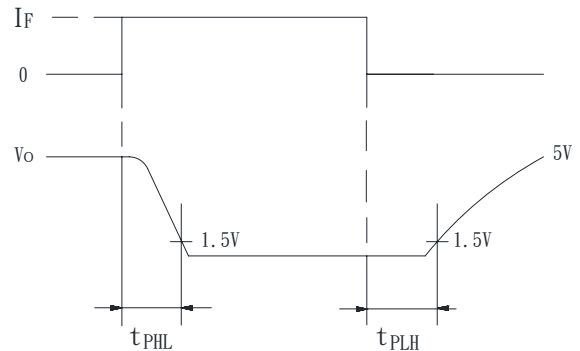
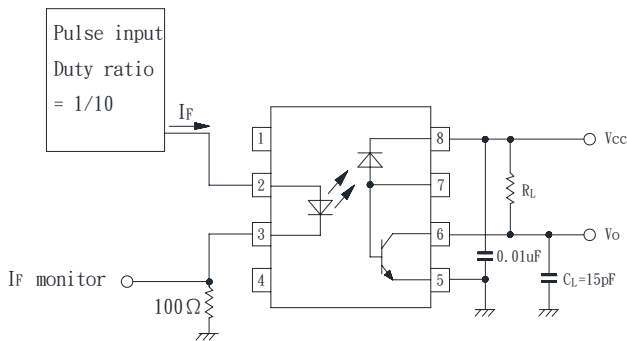

*11 Test Circuit for Instantaneous Common Mode Rejection Voltage

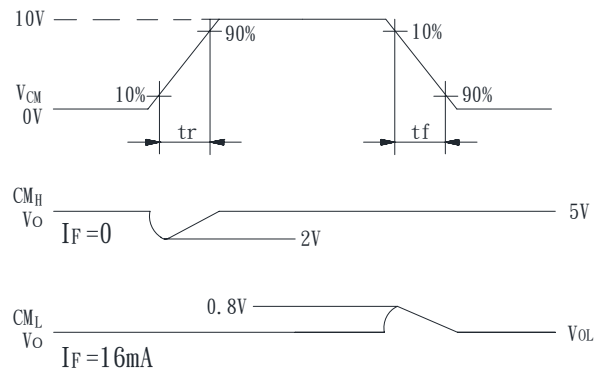
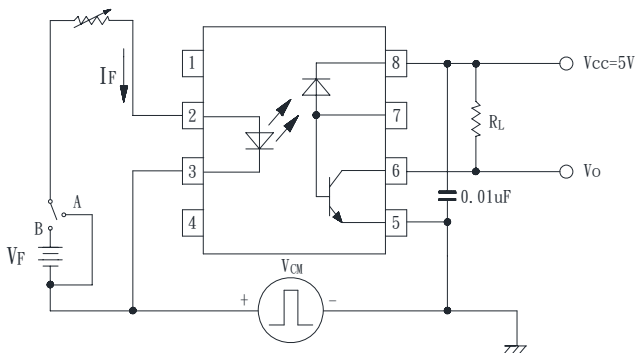

Fig.1 Forward Current vs. Ambient Temperature

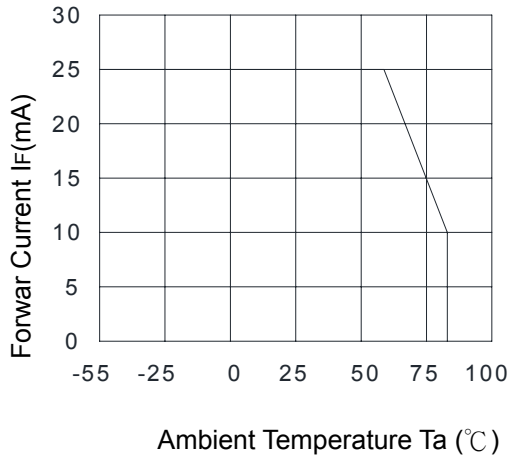

Fig.2 Power Dissipation vs. Ambient Temperature

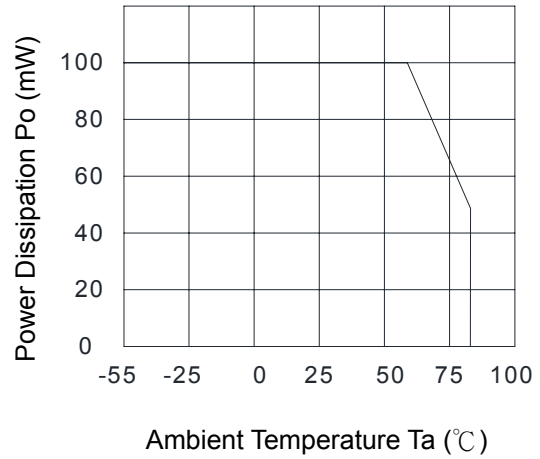

Fig.3 Forward Current vs. Forward Voltage

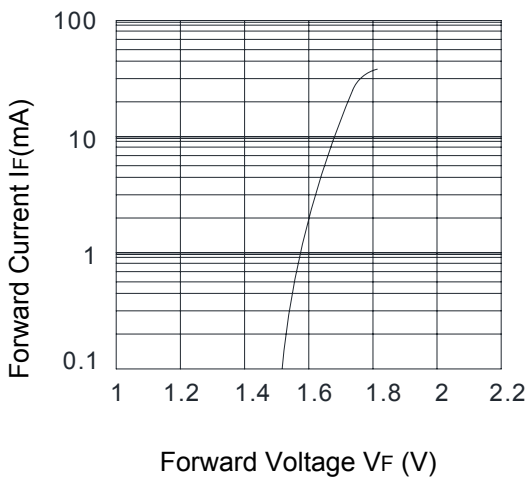

Fig.4 Current Transfer Ratio vs. Forward Current

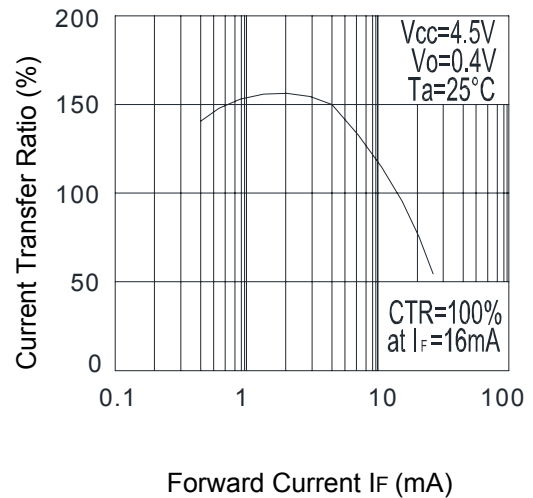

Fig.5 Output Current vs. Output Voltage

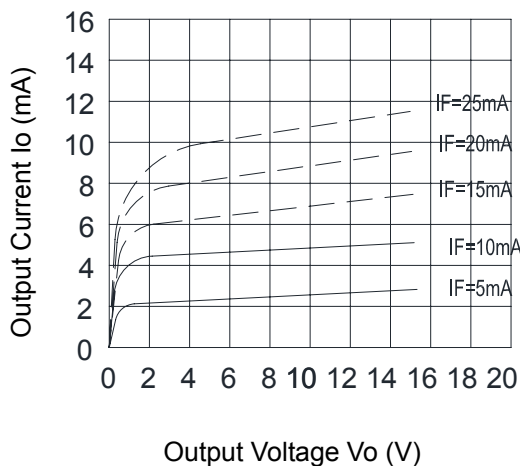

Fig.6 Current Transfer Ratio vs. Ambient Temperature

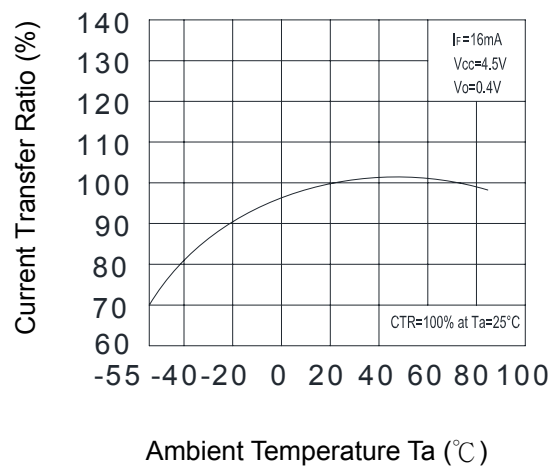

Fig.7 High Level Output Current vs. Ambient Temperature

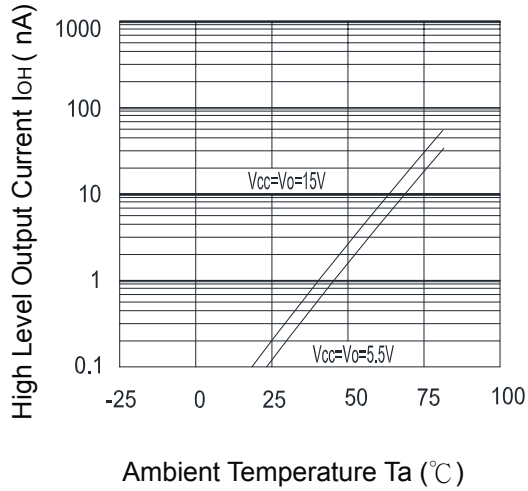
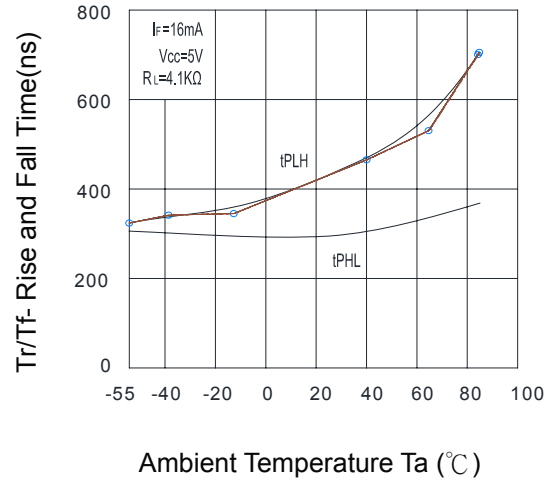

Fig.8 Propagation Delay Time vs. Ambient Temperature



● **Recommended Soldering Conditions**

(a) Infrared reflow soldering :

- Peak reflow soldering : 260°C or below (package surface temperature)
- Time of peak reflow temperature : 10 sec
- Time of temperature higher than 230°C : 30-60 sec
- Time to preheat temperature from 180~190°C : 60-120 sec
- Time(s) of reflow : Two
- Flux : Rosin flux containing small amount of chlorine (The flux with a maximum chlorine content of 0.2 Wt% is recommended.)

Recommended Temperature Profile of Infrared Reflow

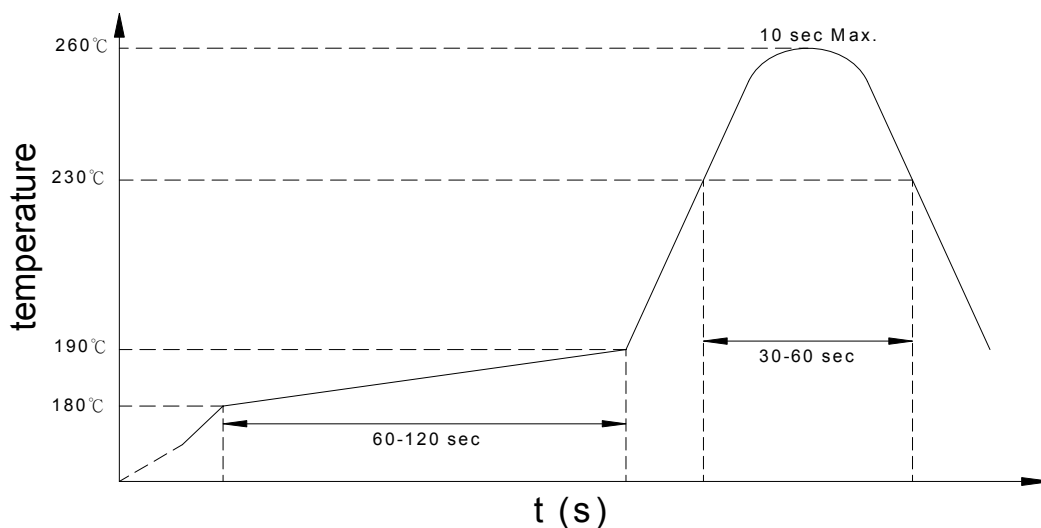

(b) Wave soldering :

- Temperature : 260°C or below (molten solder temperature)
- Time : 10 seconds or less
- Preheating conditions : 120°C or below (package surface temperature)
- Time(s) of reflow : One
- Flux : Rosin flux containing small amount of chlorine (The flux with a maximum chlorine content of 0.2 Wt% is recommended.)

(c) Cautions :

- Fluxes : Avoid removing the residual flux with freon-based and chlorine-based cleaning solvent.
- Avoid shorting between portion of frame and leads.

- **Numbering System**

KPC6N135 X (Y)

Notes:

KPC6N135 = Part No.

X = Lead form option (blank · S · H · L)

Y = Tape and reel option (TL · TR · TLD · TRU)

Option	Description	Packing quantity
S (TL)	surface mount type package + TL tape & reel option	1000 units per reel
S (TR)	surface mount type package + TR tape & reel option	1000 units per reel
L (TLD)	long creepage distance for surface mount type package + TLD tape & reel option	800 units per reel
L (TRU)	long creepage distance for surface mount type package + TRU tape & reel option	800 units per reel

- **Recommended Pad Layout for Surface Mount Lead Form**

1.Surface mount type

8-pin SMD

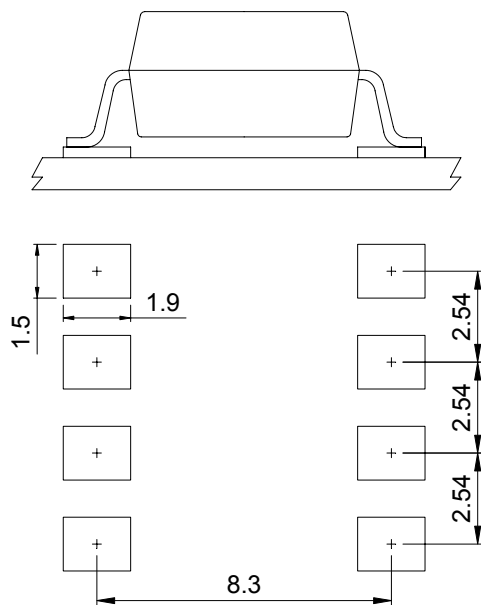

2.Long creepage distance for surface mount type

8-pin L

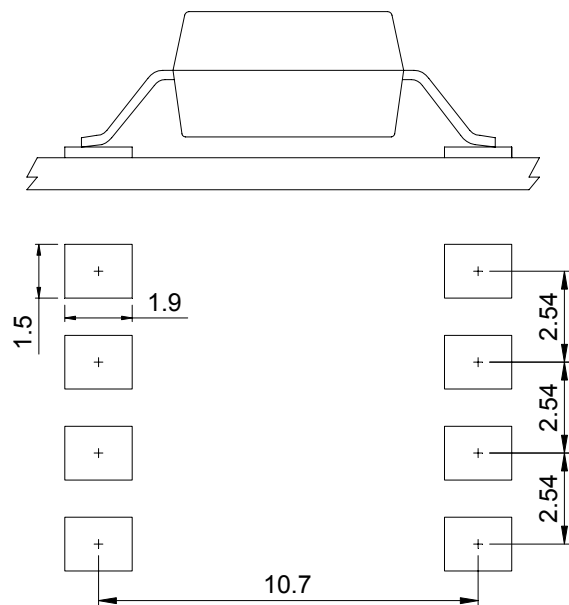

Unit : mm

● 8-pin SMD Carrier Tape & Reel

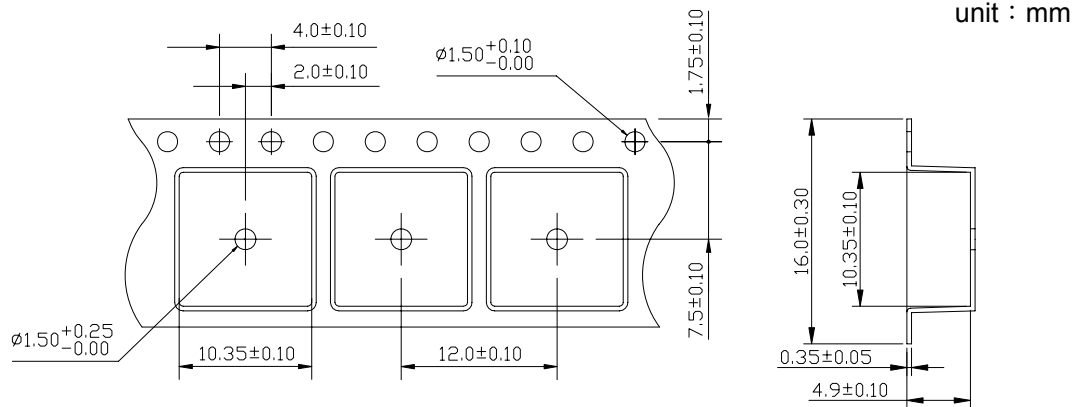

TL

TR

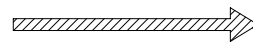
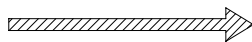
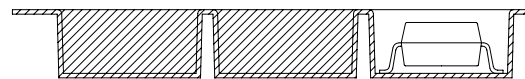
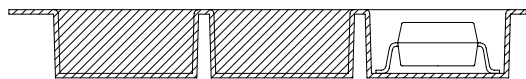
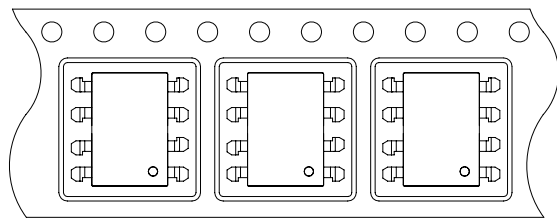
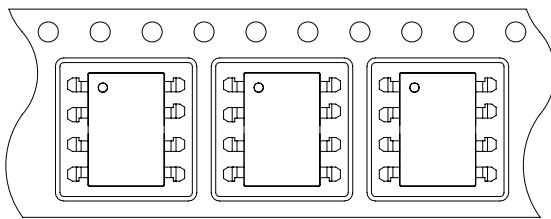

Direction of feed from reel

Direction of feed from reel

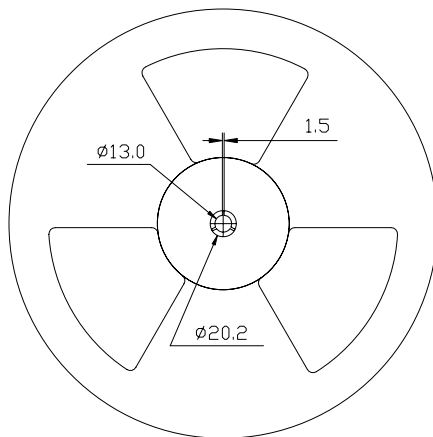

Quantity : 1000pcs/reel

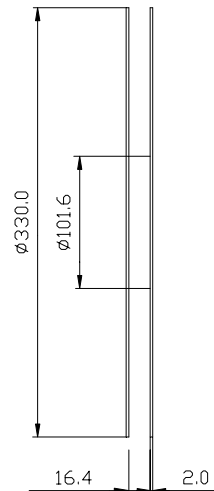

● 8-pin L Carrier Tape & Reel

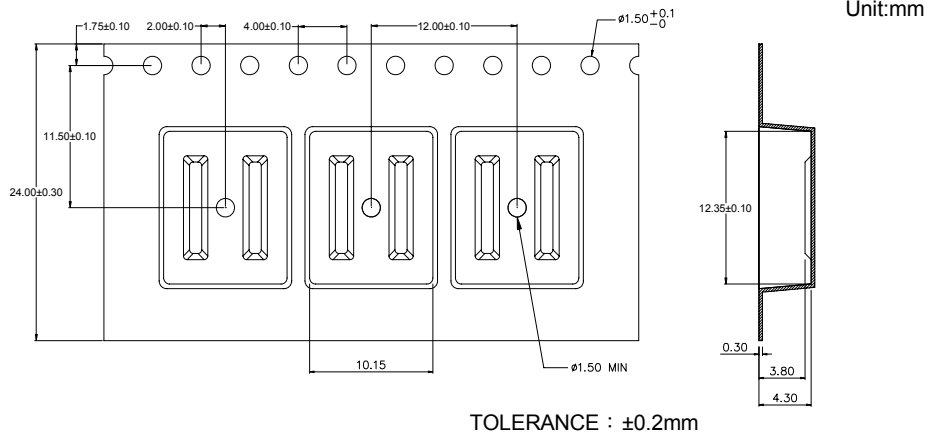

TLD

TRU

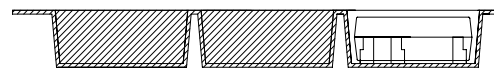
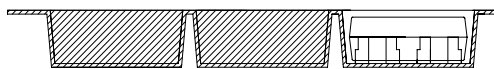
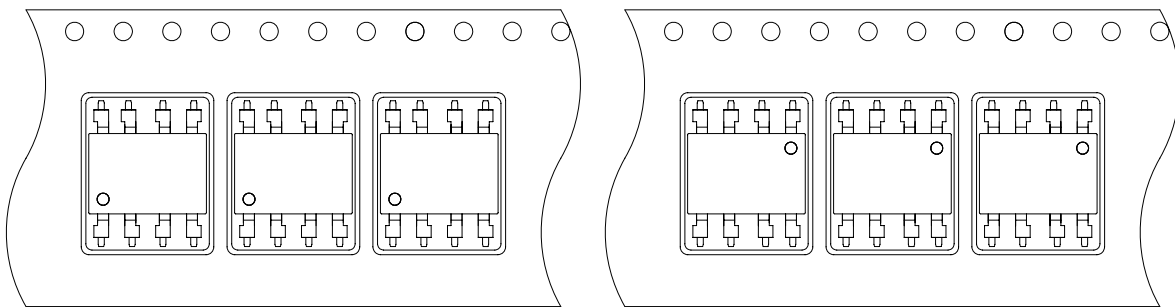

Direction of feed from reel

Direction of feed from reel

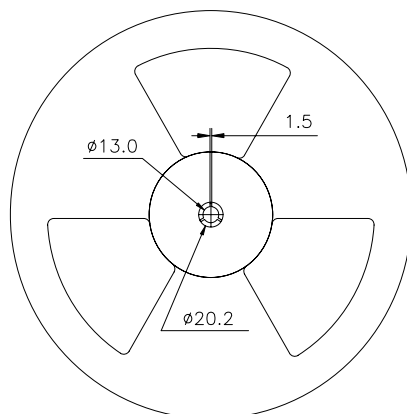

Quantity : 800pcs/reel

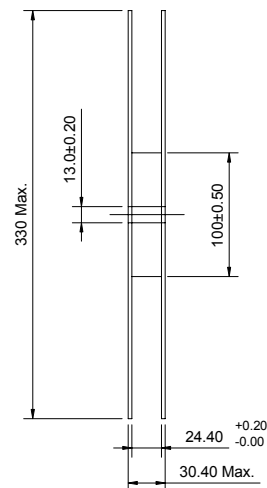



KPC6N135 Series

8PIN HIGH-SPEED OUTPUT PHOTOCOUPLER

● Application Notice

The content of datasheet is the guidance for product use only. cosmo takes no responsibility to the accuracy of the information provided here. For continuously improving all of products, including quality, reliability, function...etc., cosmo reserves the right to change the specification, characteristics, data, materials, and structure of products without notice. Please contact with cosmo to obtain the latest specification.

It would be required to comply with the absolute maximum ratings listed in the specification. cosmo has no liability and responsibility to the damage caused by improper use of the products.

cosmo products are intended to be designed for use in general electronics application list below:

- a. Personal computer
- b. OA machine
- c. Audio / Video
- d. Instrumentation
- e. Electrical application
- f. Measurement equipment
- g. Consumer electronics
- h. Telecommunication

cosmo devices shall not be used or related with equipment requiring higher level of quality / reliability, or malfunction, or failure which may cause loss of human life, bodily injury, includes, without limitation:

- a. Medical and other life supporting equipments
- b. Space application
- c. Telecommunication equipment (trunk lines)
- d. Nuclear power control
- e. Equipment used for automotive vehicles, trains, ships...etc.

This publication is the property of cosmo. No part of this publication may be reproduced or copied in any form or any means electronically or mechanically for any purpose, in whole or in part without any written permission expressed from cosmo.