

● Description

The KP1510 series consists of GaAlAs Light emitter diode and an integrated. This unit is 8-lead DIP package. KP1510 series is suitable for gate driving circuit of IGBT or power MOSFET.

● Schematic

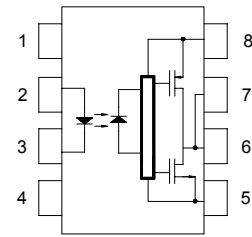

- | | |
|------------|------------------------|
| 1. N.C. | 5. GND |
| 2. Anode | 6. Vo (Voltage Output) |
| 3. Cathode | 7. Vo (Voltage Output) |
| 4. N.C. | 8. Vcc |

● Features

1. High noise immunity characterized by 25kV/ μ s
minimum common mode rejection(CM_R)at $V_{CM}=1500V$
2. 2.5A maximum peak output current
3. $I_{CC} = 5mA$ maximum supply current
4. Wide supply voltage range from 15V to 30V
5. Fast power switching application
 - 500ns max. propagation delay
 - 100ns min. P_{WD} protection scheme
6. Under Voltage Lock-Out (UVLO) with hysteresis
7. Industrial temperate range: -30°C to 115°C
8. Agency Approvals:
 - UL1577 / CUL C22.2 No.1 & NTC No.5, File No. E169586
 - VDE EN 60747-5-2, File No. 40020973

● Applications

- Industrial inverters
- Switch mode power supply
- AC/Brushless DC motor drives
- IGBT/Power MOSFET gate drive

● Truth Table

LED	OUTPUT	Q1	Q2
ON	HIGH LEVEL	ON	OFF
OFF	LOW LEVEL	OFF	ON

* The use of a 0.1 μ F bypass capacitor must be connected between pins 8 and 5 is recommended.

● **Outside Dimension**

Unit : mm

1. Dual-in-line type

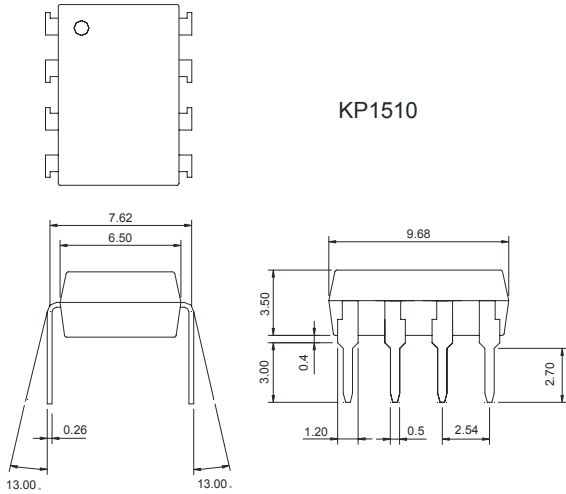

2. Surface mount type

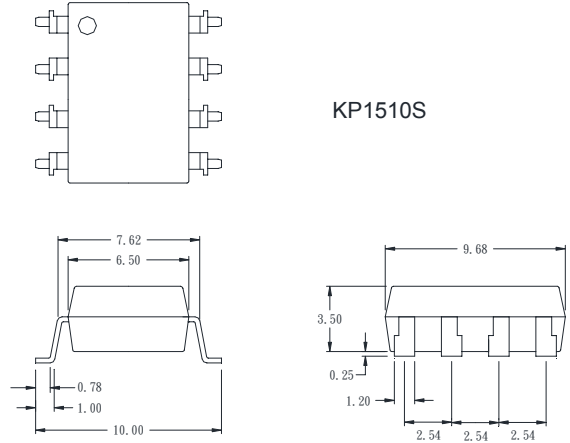

3. Long creepage distance type

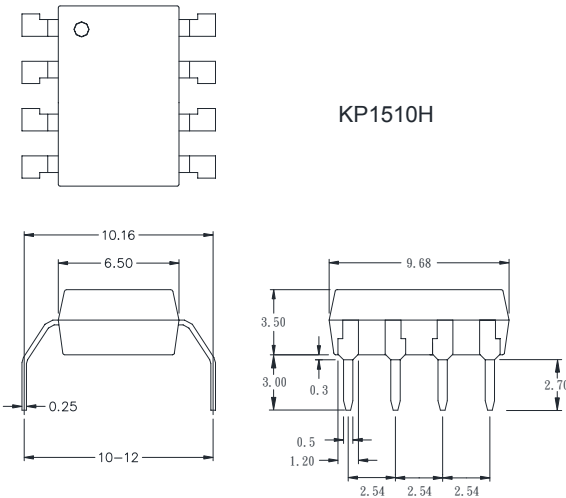

4. Long creepage distance for surface mount type

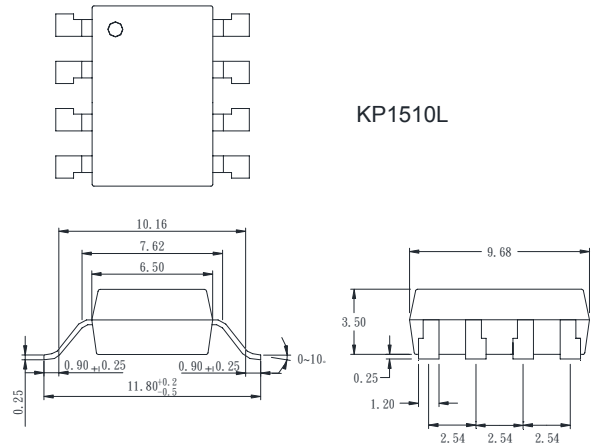

TOLERANCE: ±0.2mm

● **Device Marking**

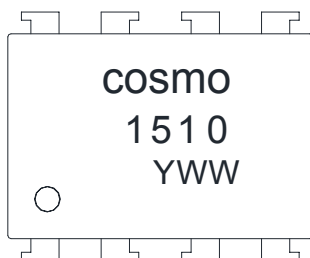

Notes:

COSMO
1510
YWW Y: Year code / WW: Week code

● Absolute Maximum Ratings

(Ta = 25°C)

Parameter	Symbol	Rating	Unit
Storage temperature	T _{STG}	-55 to +125	°C
Operating temperature	T _{OPR}	-40 to +115	°C
Junction temperature	T _J	-30 to +125	°C
Lead wave solder temperature	T _{SOL}	260 for 10 Secs	°C
Average input current	I _{F(AVG)}	20	mA
Peak transient forward current ⁽¹⁰⁾	I _{F(PEAK)}	1	A
Operating frequency ⁽¹¹⁾	f	50	KHz
Reverse input voltage	V _R	5	V
Peak output current ⁽¹⁾	I _{O(PEAK)}	2.5	A
Supply voltage TA ≥ 90°C	V _{CC} - V _{EE}	0 to 35	V
		0 to 30	
Peak output voltage	V _{O(PEAK)}	0 to V _{CC}	V
Input signal rise and fall time	t _{R(IN)} - t _{F(IN)}	500	ns
Input power dissipation ⁽²⁾⁽⁴⁾	P _{DI}	45	mW
Output power dissipation ⁽³⁾⁽⁴⁾	P _{DO}	250	mW

● Recommended Operating Conditions

Parameter	Symbol	Rating	Unit
Ambient operating temperature	T _A	-40 to +115	°C
Power supply	V _{CC} - V _{EE}	15 to 30	V
Input current (On)	I _{F(ON)}	7 to 16	mA
Input voltage (Off)	V _{F(OFF)}	-3.6 to 0.8	V

● Isolation Characteristics

Parameter	Symbol	Rating	Min.	Typ.	Max.	Unit
Input-output isolation voltage	V _{ISO}	V _A =25°C, R.H.<50%, t=1.0min, I ₁₋₀ ≤ 10uA, 50Hz ⁽⁵⁾⁽⁶⁾	5000	—	—	V _{RMS}
Isolation resistance	R _{ISO}	V ₁₋₀ =500V ⁽⁵⁾	10 ¹¹	—	—	Ω
Isolation capacitance	C _{ISO}	V ₁₋₀ =0V, Freq=1.0MHz ⁽⁵⁾	—	—	1	pF

● Electrical Characteristics

(Ta = 25°C)

Parameter	Symbol	Test Condition	Min.	Typ.	Max.	Unit	
Input forward voltage	V_F	$I_F=10\text{mA}$	1.2	1.5	1.8	V	
Temperature coefficient of forward voltage	$\Delta(V_F/\Delta T_A)$		—	-1.8	—	mV/°C	
Input reverse breakdown voltage	BV_R	$I_R=10\mu\text{A}$	5	—	—	V	
Input capacitance	C_{IN}	$f=1\text{MHz}$, $V=0$	—	60	—	pF	
Output current (*A)	“H” level ⁽¹⁾	I_{OH}	$V_O = V_{CC}-2.5\text{V}$	0.5	1.5	—	A
			$V_O = V_{CC}-4\text{V}$	2.0	—	—	
	“L” level ⁽¹⁾	I_{OL}	$V_O = V_{EE}+2.5\text{V}$	0.5	2.0	—	A
			$V_O = V_{EE}+4\text{V}$	2.0	—	—	
Output voltage	“H” level	V_{OH}	$I_F = 10\text{mA}$, $I_O = -100\text{mA}$	$V_{CC}-4\text{V}$	$V_{CC}-3\text{V}$	—	V
	“L” level	V_{OL}	$I_F = 0\text{mA}$, $I_O = 100\text{mA}$	—	$V_{EE}+0.1\text{V}$	$V_{EE}+0.5\text{V}$	
Supply current	“H” level	I_{CCH}	$V_O = \text{Open}$, $I_F = 7$ to 16mA	—	2.5	5.0	mA
	“L” level	I_{CCL}	$V_O = \text{Open}$, $V_F = -3.0$ to 0.8V	—	2.5	5.0	
Threshold input current	“Output L→H”	I_{FLH}	$I_O = 0\text{mA}$, $V_O > 5\text{V}$	—	2.3	5.0	mA
Threshold input voltage	“Output H→L”	V_{FHL}	$I_O = 0\text{mA}$, $V_O < 5\text{V}$	0.7	—	—	V
Under voltage lockout threshold		V_{UVLO+}	$I_F = 10\text{mA}$, $V_O > 5\text{V}$	11.0	12.3	13.5	V
		V_{UVLO-}	$I_F = 10\text{mA}$, $V_O < 5\text{V}$	9.0	10.7	12.0	
Under voltage lockout threshold hysteresis		$UVLO_{HYS}$		—	1.6	—	V

● Switching Characteristics

(Ta = 25°C)

Parameter		Symbol	Test Condition	Min.	Typ.	Max.	Unit	
Propagation delay time	“L→H”	t_{pLH}	$I_F=7mA$ to $16mA$ $R_g=10\Omega, C_g=10nF$ $F=10KHz, Duty\ Cycle=50\%$	0.1	0.3	0.5	us	
	“H→L”	t_{pHL}		0.1	0.3	0.5	us	
Pulse width distortion $t_{pHL} - t_{pLH}$		P_{WD}		—	—	0.3	us	
Propagation delay difference Between Any Two Parts or Channels ($t_{pHL} - t_{pLH}$) ⁽⁷⁾		P_{DD} (Skew)		-0.35	—	0.35	us	
Output rise time (10%-90%)		t_r		—	0.1	—	us	
Output fall time		t_f		—	0.1	—	us	
UVLO turn-on delay		$T_{UVLO\ ON}$		$I_F = 10mA, V_O > 5V$	—	0.8	—	us
UVLO turn-off delay		$T_{UVLO\ OFF}$		$I_F = 10mA, V_O < 5V$	—	0.6	—	us
Common mode transient immunity at high level output		$ C_{MH} $		$T_A=25^\circ C, V_{CC}=30V,$ $I_F=10mA$ to $16mA$ $V_{CM}=1500V^{(8)}$	25	35	—	KV / μs
Common mode transient immunity at low level output		$ C_{ML} $		$T_A=25^\circ C, V_{CC}=30V,$ $V_F=0V$ $V_{CM}=1500V^{(9)}$	25	35	—	KV / μs

Notes:

1. Maximum pulse width = 10 μs , maximum duty cycle = 1.1%
2. Derate linearly above 87°C, free air temperature at a rate of 0.77mW/°C
3. No derating required across temperature range.
4. Functional operation under these conditions is not implied. Permanent damage may occur if the device is subjected to conditions outside these ratings.
5. Device is considered a two terminal device: Pins 2 and 3 are shorted together and Pins 5, 6, 7 and 8 are shorted together.
6. 5,000 VRMS for 1 minute duration is equivalent to 6,000 VACRMS for 1 second duration.
7. The difference between t_{pHL} and t_{pLH} between any two KP1510 parts under same test conditions.
8. Common mode transient immunity at output high is the maximum tolerable negative dV_{cm}/dt on the trailing edge of the common mode impulse signal, V_{cm} , to assure that the output will remain high (i.e. $V_O > 15.0V$).
9. Common mode transient immunity at output low is the maximum tolerable positive dV_{cm}/dt on the leading edge of the common pulse signal, V_{cm} , to assure that the output will remain low (i.e. $V_O < 1.0V$).
10. Pulse Width, PW δ 1 μs , 300pps
11. Exponential Waveform, $I_o(PEAK) \leq |2.5A| (\leq 0.3\mu s)$

Fig.1 Forward Current vs. Forward Voltage

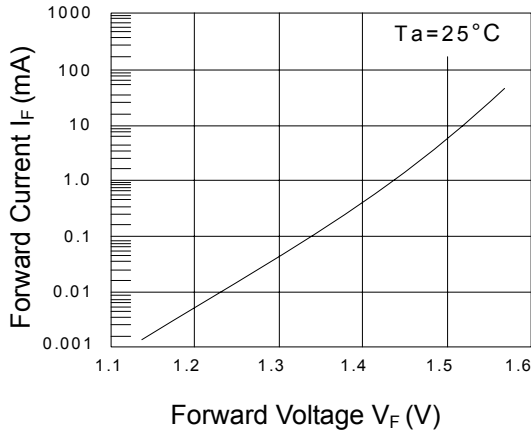

Fig.2 Output Voltage vs. Forward Current

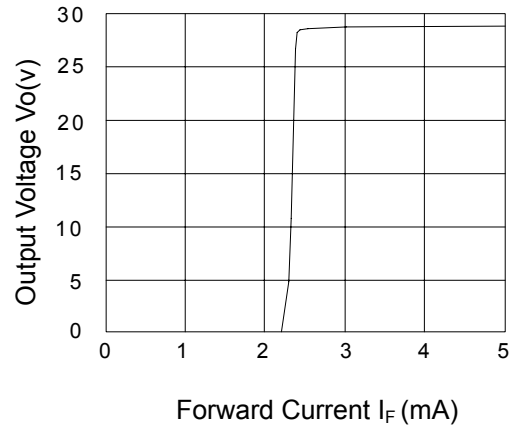

Fig.3 Output High Current vs. Ambient Temperature

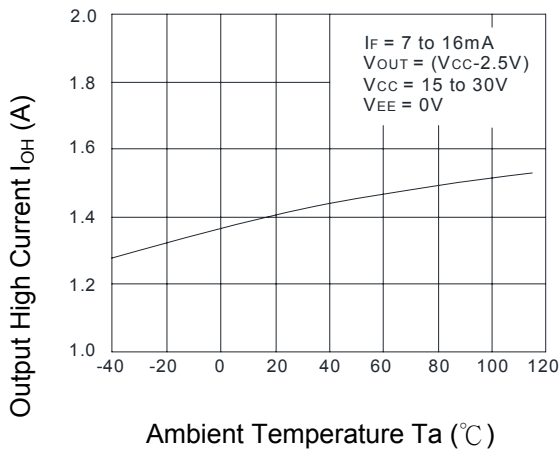

Fig.4 Output High Voltage vs. Output High Current

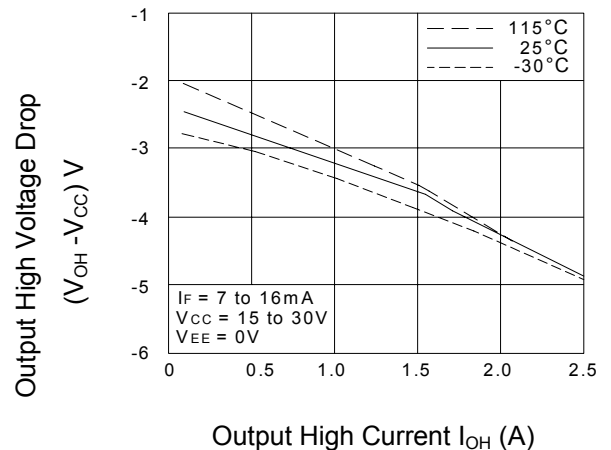

Fig.5 Output Low Current vs. Ambient Temperature

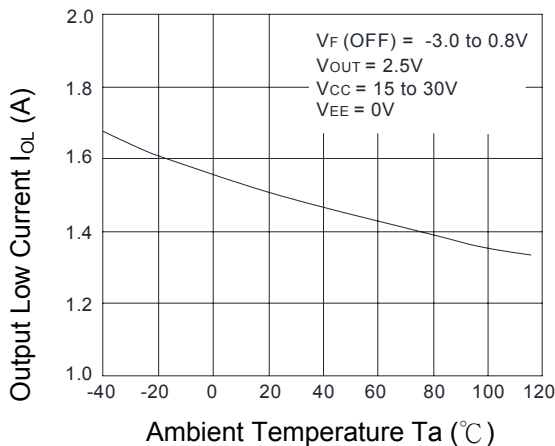

Fig.6 Output Low Voltage vs. Output Low Current

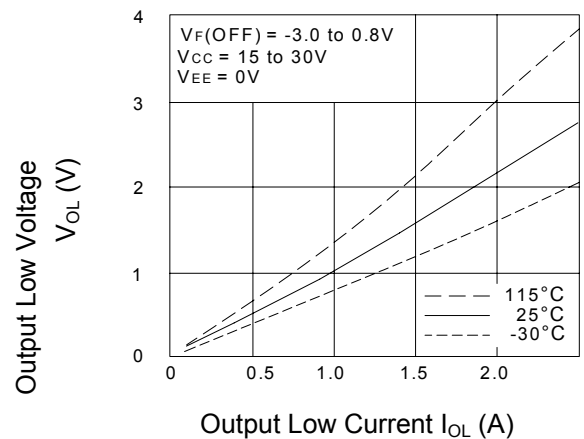

Fig.7 Propagation Delay vs. Forward Current

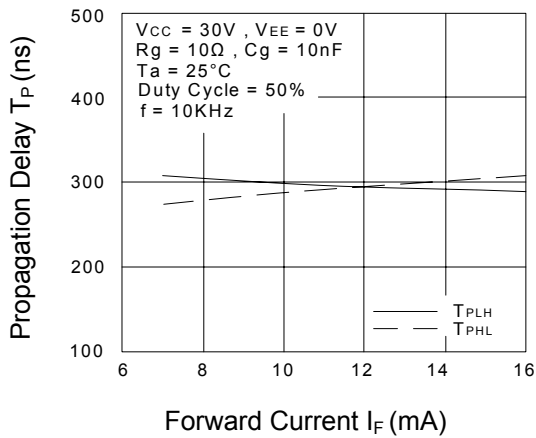

Fig.8 Propagation Delay vs. Ambient Temperature

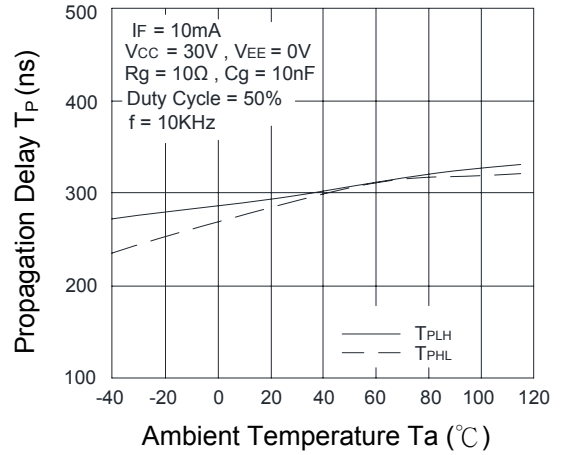

Fig.9 Propagation Delay vs. Series Load Resistance

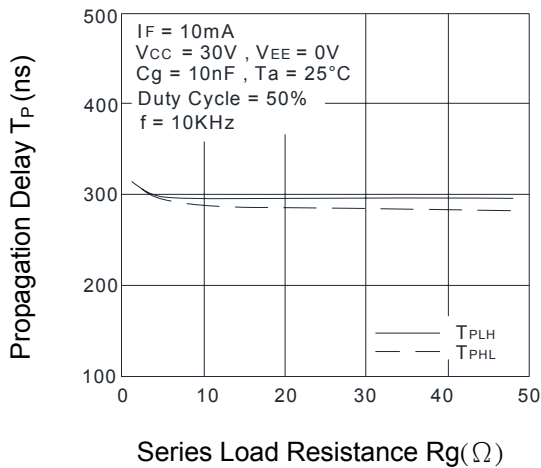
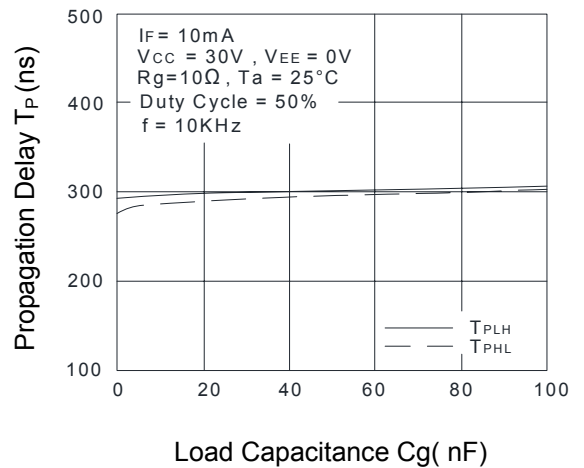

Fig.10 Propagation Delay vs. Load Capacitance



● **Test Circuit**

Fig.11 Top View

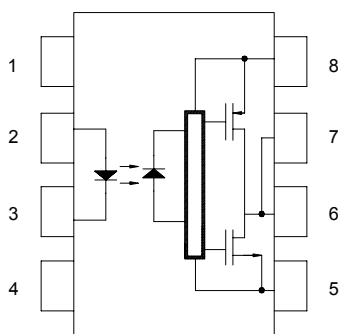

Fig.12 I_{OPL} Measure

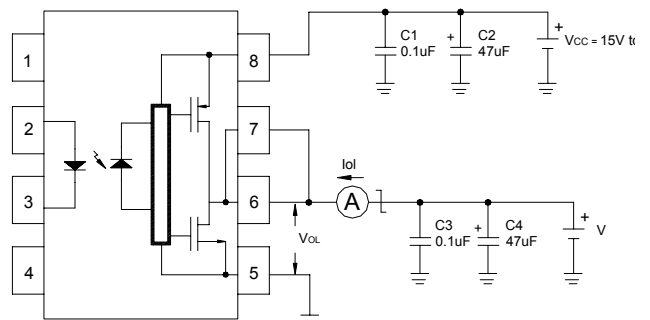

Fig.13 I_{OPH} Measure

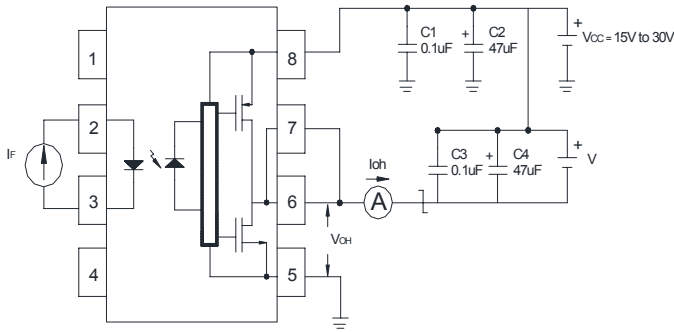

Fig.14 V_{OL} Measure

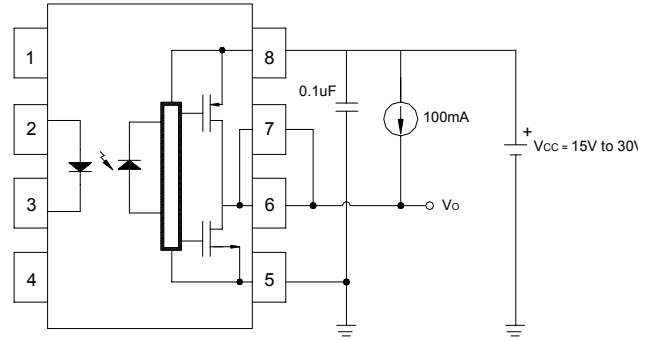

Fig.15 V_{OH} Measure

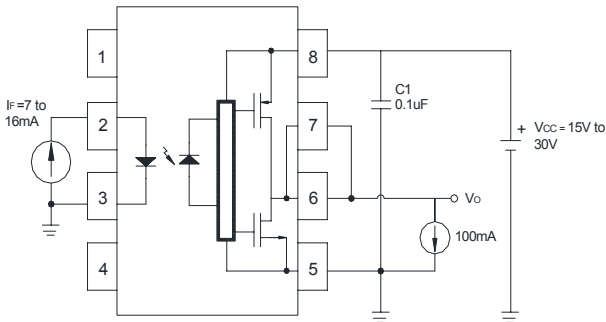

Fig.16 t_{pLH}, t_{pHL}, t_r, t_f Measure

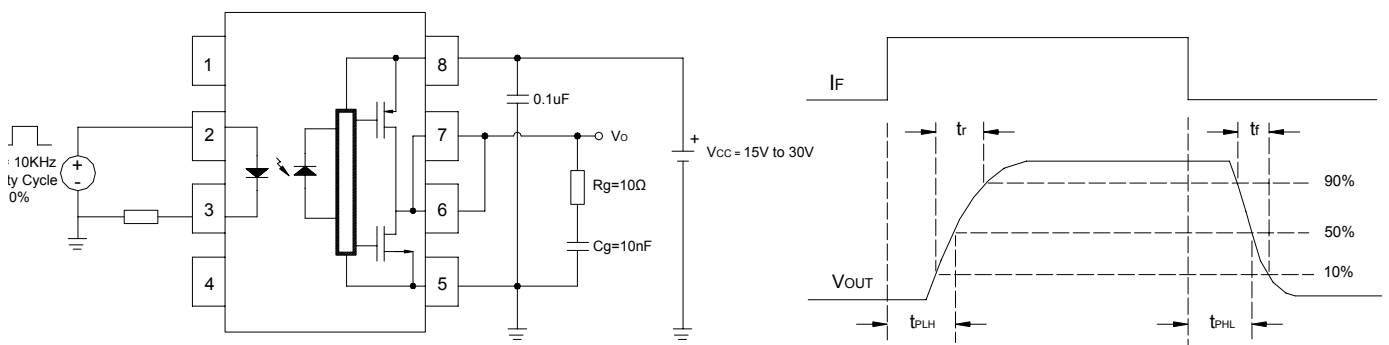
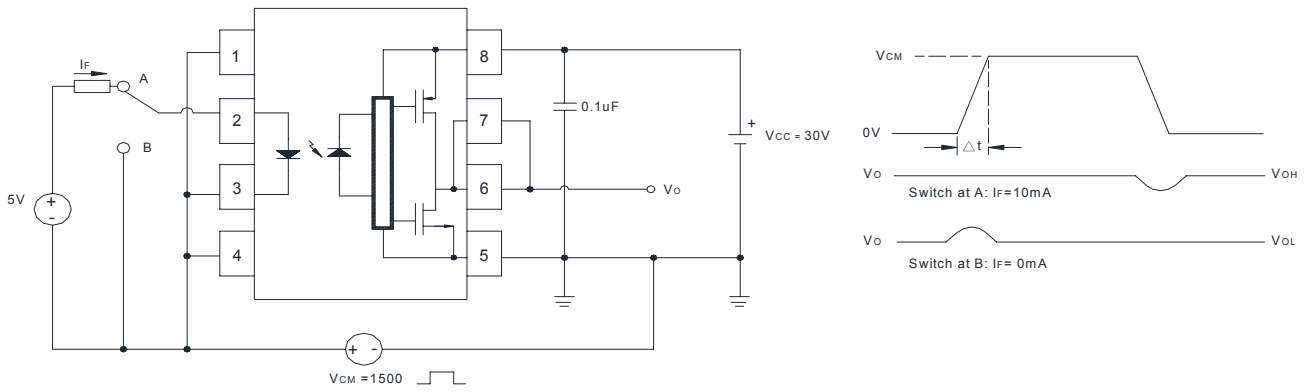

Fig.17 C_{MH} , C_{ML} , Measure



* C_{ML} (C_{MH}) is the maximum rate of rise (fall) of the common mode voltage that can be sustained with the output voltage in the low (high) state.

● **Recommended Soldering Conditions**

(a) Infrared reflow soldering :

- Peak reflow soldering : 260°C or below (package surface temperature)
- Time of peak reflow temperature : 10 sec
- Time of temperature higher than 230°C : 30-60 sec
- Time to preheat temperature from 180~190°C : 60-120 sec
- Time(s) of reflow : Two
- Flux : Rosin flux containing small amount of chlorine (The flux with a maximum chlorine content of 0.2 Wt% is recommended.)

Recommended Temperature Profile of Infrared Reflow

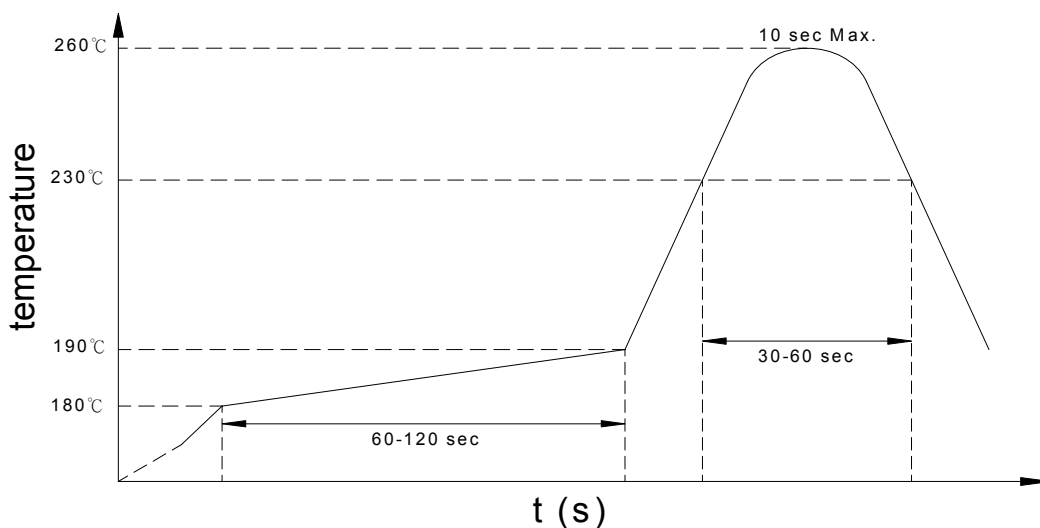

(b) Wave soldering :

- Temperature : 260°C or below (molten solder temperature)
- Time : 10 seconds or less
- Preheating conditions : 120°C or below (package surface temperature)
- Time(s) of reflow : One
- Flux : Rosin flux containing small amount of chlorine (The flux with a maximum chlorine content of 0.2 Wt% is recommended.)

(c) Cautions :

- Fluxes : Avoid removing the residual flux with freon-based and chlorine-based cleaning solvent.
- Avoid shorting between portion of frame and leads.

- **Numbering System**

KP1510 X (Y)

Notes:

KP1510 = Part No.

X = Lead form option (blank · S · H · L)

Y = Tape and reel option (TL · TR · TLD · TRU)

Option	Description	Packing quantity
S (TL)	surface mount type package + TL tape & reel option	1000 units per reel
S (TR)	surface mount type package + TR tape & reel option	1000 units per reel
L (TLD)	long creepage distance for surface mount type package + TLD tape & reel option	800 units per reel
L (TRU)	long creepage distance for surface mount type package + TRU tape & reel option	800 units per reel

- **Recommended Pad Layout for Surface Mount Lead Form**

1.Surface mount type

8-pin SMD

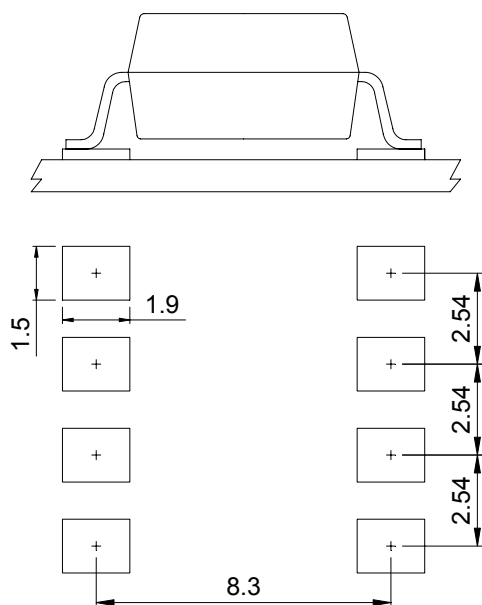

2.Long creepage distance for surface mount type

8-pin L

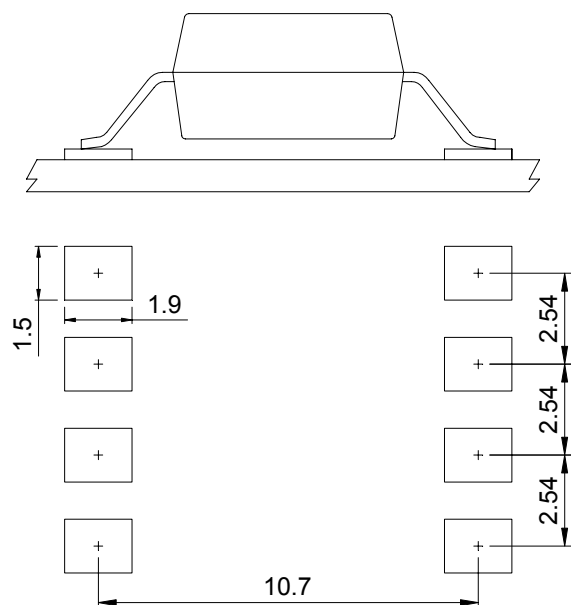

Unit :mm

● 8-pin SMD Carrier Tape & Reel

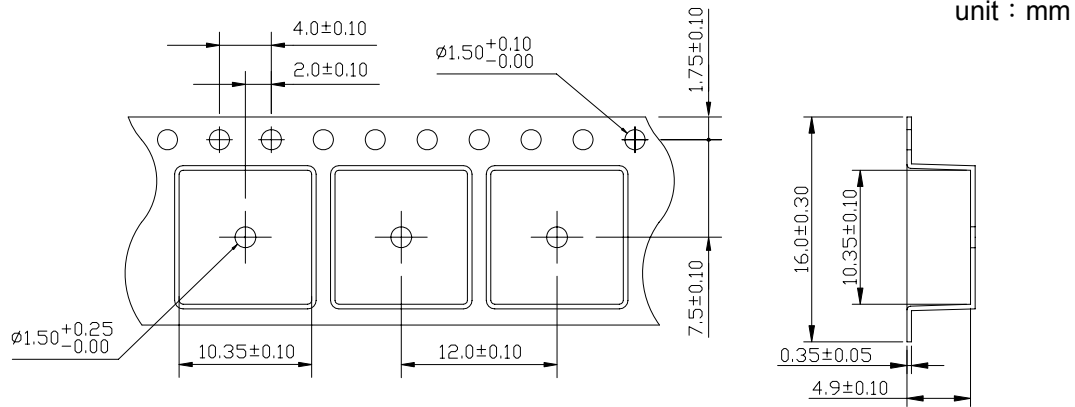

TL

TR

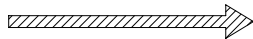
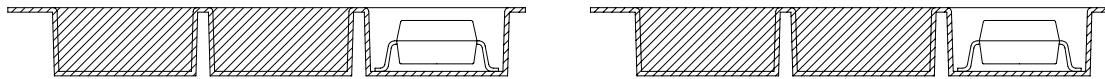
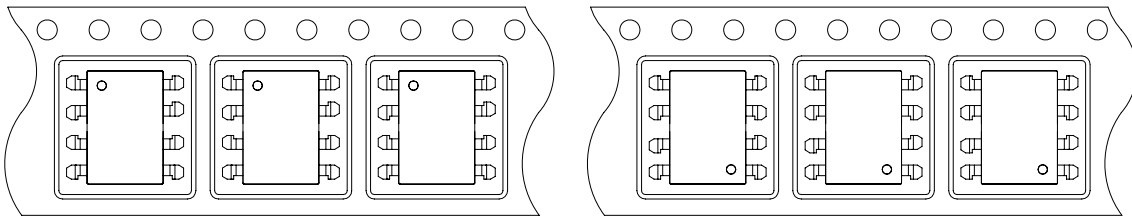

Direction of feed from reel

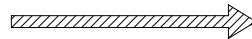

Direction of feed from reel

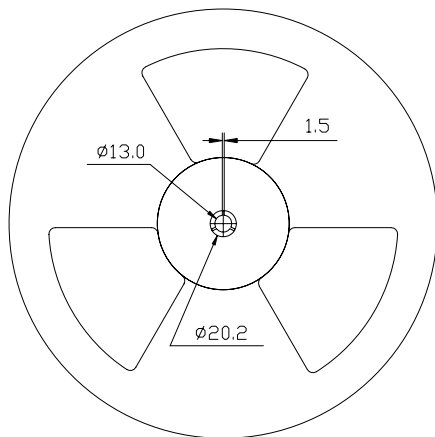

Quantity : 1000pcs/reel

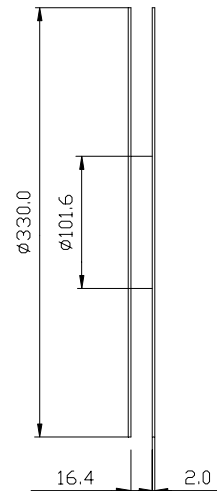

● 8-pin L Carrier Tape & Reel

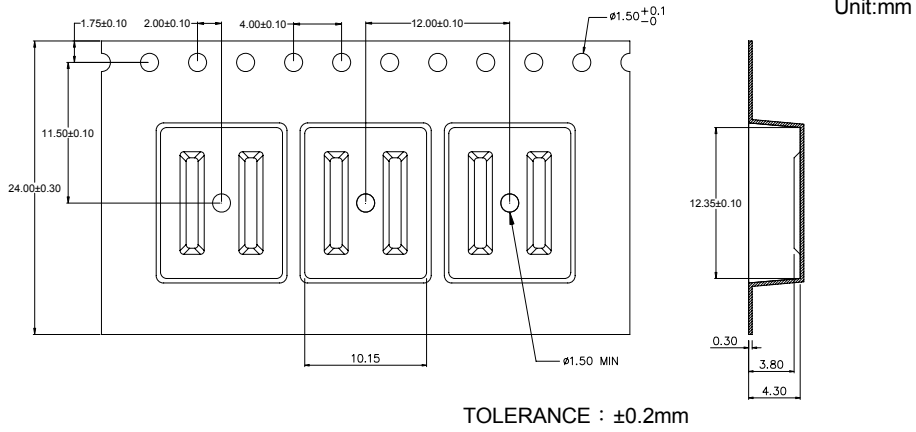

TLD

TRU

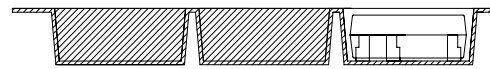
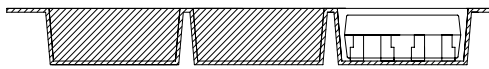
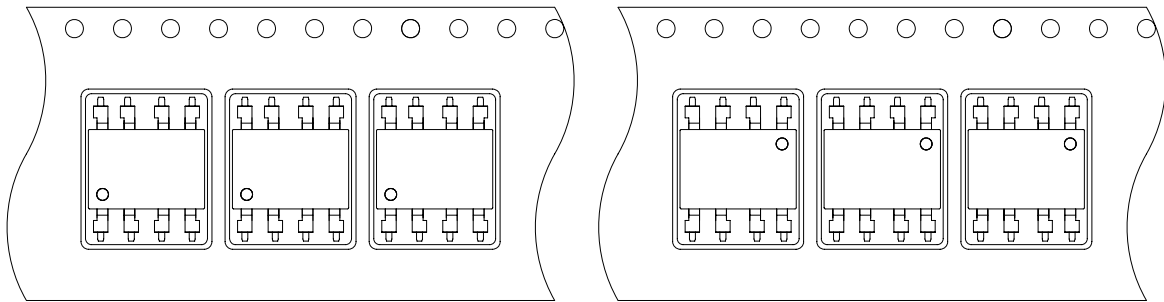

Direction of feed from reel

Direction of feed from reel

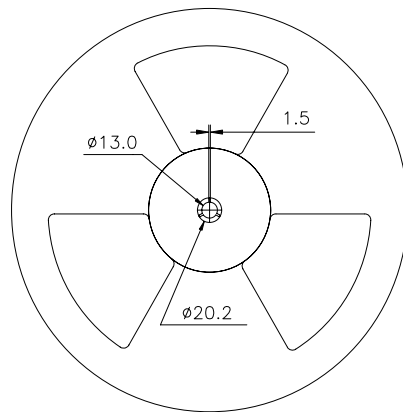

Quantity : 800pcs/reel

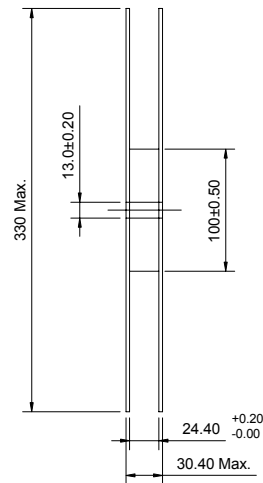

- **Application Notice**

The content of datasheet is the guidance for product use only. cosmo takes no responsibility to the accuracy of the information provided here. For continuously improving all of products, including quality, reliability, function...etc., cosmo reserves the right to change the specification, characteristics, data, materials, and structure of products without notice. Please contact with cosmo to obtain the latest specification.

It would be required to comply with the absolute maximum ratings listed in the specification. cosmo has no liability and responsibility to the damage caused by improper use of the products.

cosmo products are intended to be designed for use in general electronics application list below:

- a. Personal computer
- b. OA machine
- c. Audio / Video
- d. Instrumentation
- e. Electrical application
- f. Measurement equipment
- g. Consumer electronics
- h. Telecommunication

cosmo devices shall not be used or related with equipment requiring higher level of quality / reliability, or malfunction, or failure which may cause loss of human life, bodily injury, includes, without limitation:

- a. Medical and other life supporting equipments
- b. Space application
- c. Telecommunication equipment (trunk lines)
- d. Nuclear power control
- e. Equipment used for automotive vehicles, trains, ships...etc.

This publication is the property of cosmo. No part of this publication may be reproduced or copied in any form or any means electronically or mechanically for any purpose, in whole or in part without any written permission expressed from cosmo.