

### ● Description

The KPC825 series consist of a photodarlington optically coupled to a gallium arsenide infrared-emitting diode in a 8-pin DIP package and available in wide-lead spacing and SMD option. The input-output isolation voltage is rated at 5000 Vrms.

### ● Features

1. Current transfer ratio  
( CTR : Min. 600% at  $I_F=1\text{mA}$   $V_{CE}=2\text{V}$  )
2. High isolation voltage between input and output  
( Viso : 5000Vrms )
3. Compact dual-in-line package
4. Pb free and RoHS compliant
5. Agency Approvals
  - UL1577 / CUL C22.2 No.1 & NTC No.5, File No. E169586
  - VDE EN60747, File No. 40005500
  - FIMKO EN60065, File No. FI25798
  - FIMKO EN60950, File No. FI25798

### ● Applications

- System appliances, measuring instruments
- Industrial robots
- Copiers, automatic vending machines
- Signal transmission between circuits of different potentials and impedances

### ● Schematic

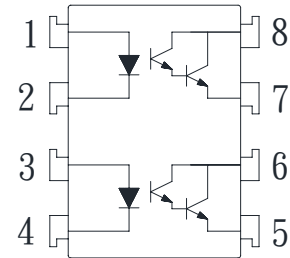

- 1 、 3. Anode
- 2 、 4. Cathode
- 5 、 7. Emitter
- 6 、 8. Collector

● **Outside Dimension**

Unit : mm

1. Dual-in-line type.

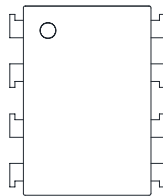

**KPC825**

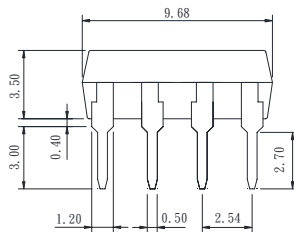
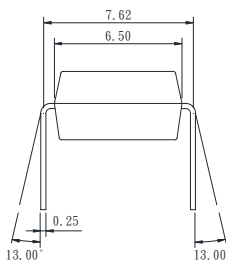

2. Surface mount type.

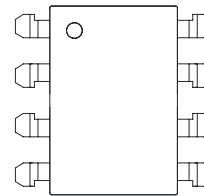

**KPC825S**

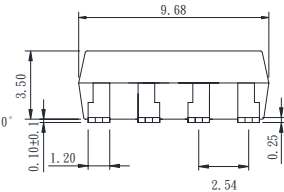
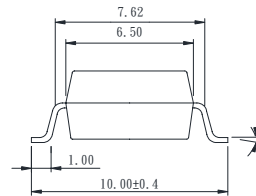

3. Long creepage distance type

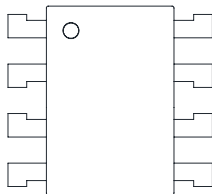

**KPC825H**

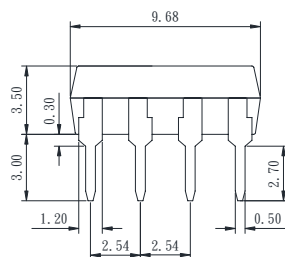
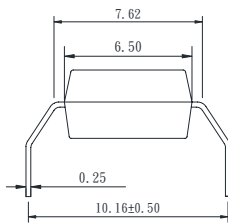

4. Long creepage distance for surface mount type.

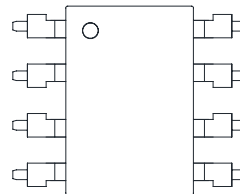

**KPC825L**

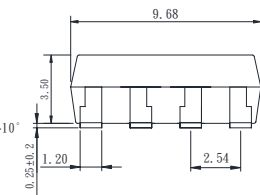
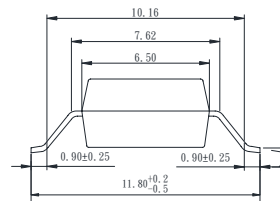

TOLERANCE : ±0.2mm

● **Device Marking**

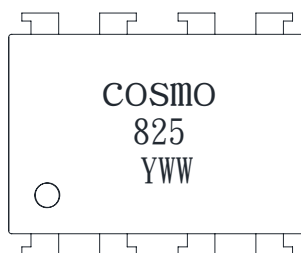

**Notes:**

**COSMO**  
**825**  
**YWW**

Y: Year code / WW: Week code

### ● Absolute Maximum Ratings

(Ta=25°C)

Parameter		Symbol	Rating	Unit
Input	Forward current	$I_F$	50	mA
	Peak forward current	$I_{FM}$	1	A
	Reverse voltage	$V_R$	6	V
	Power dissipation	$P_D$	70	mW
Output	Collector-emitter voltage	$V_{CEO}$	35	V
	Emitter-collector voltage	$V_{ECO}$	6	V
	Collector current	$I_C$	80	mA
	Collector power dissipation	$P_C$	150	mW
Total power dissipation		$P_{tot}$	200	mW
Isolation voltage 1 minute		$V_{iso}$	5000	Vrms
Operating temperature		$T_{opr}$	-55 to +115	°C
Storage temperature		$T_{stg}$	-55 to +125	°C
Soldering temperature 10 seconds		$T_{sol}$	260	°C

### ● Electro-optical Characteristics

(Ta=25°C)

Parameter		Symbol	Conditions	Min.	Typ.	Max.	Unit
Input	Forward voltage	$V_F$	$I_F=20mA$	-	1.2	1.4	V
	Peak forward voltage	$V_{FM}$	$I_{FM}=0.5A$	-	-	3.5	V
	Reverse current	$I_R$	$V_R=4V$	-	-	10	uA
	Terminal capacitance	$C_t$	$V=0, f=1KHz$	-	30	250	pF
Output	Collector dark current	$I_{CEO}$	$V_{CE}=10V, I_F=0$	-	-	1.0	μA
Transfer characteristics	Current transfer ratio	CTR	$I_F=1mA, V_{CE}=2V$	600	-	7500	%
	Collector-emitter saturation	$V_{CE(sat)}$	$I_F=20mA, I_C=5mA$	-	0.8	1.0	V
	Isolation resistance	$R_{iso}$	DC500V	$5 \times 10^{10}$	-	-	Ω
	Floating capacitance	$C_f$	$V=0, f=1MHz$	-	0.6	1.0	pF
	Cut-off frequency	$f_C$	$V_{CC}=5V, I_C=20mA, R_L=100\Omega$	1	6	-	KHz
	Response time ( Rise )	$t_r$	$V_{CE}=2V, I_C=20mA, R_L=100\Omega$	-	5	40	μs
	Response time ( Fall )	$t_f$		-	60	100	μs

Classification table of current transfer ratio is shown below.

KPC825 Model No.	CTR (%)
KPC825 E	600 ~ 7500

**Fig.1 Current Transfer Ratio vs. Forward Current**

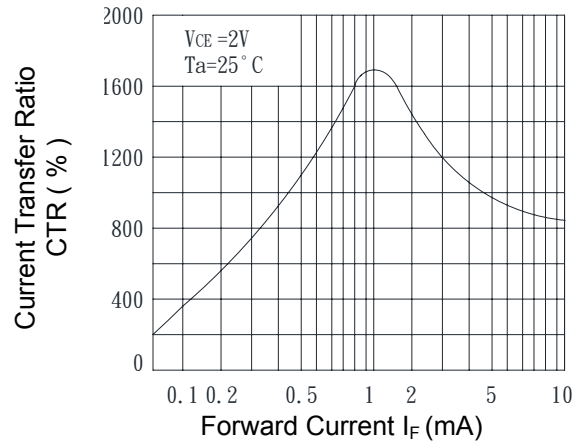

**Fig.2 Collector Power Dissipation vs. Ambient Temperature**

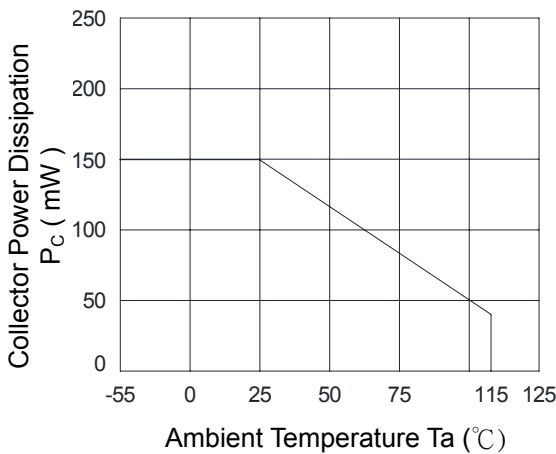

**Fig.3 Collector Dark Current vs. Ambient Temperature**

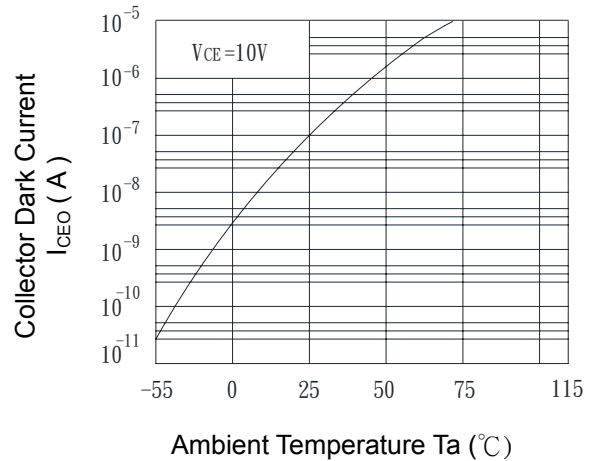

**Fig.4 Forward Current vs. Ambient Temperature**

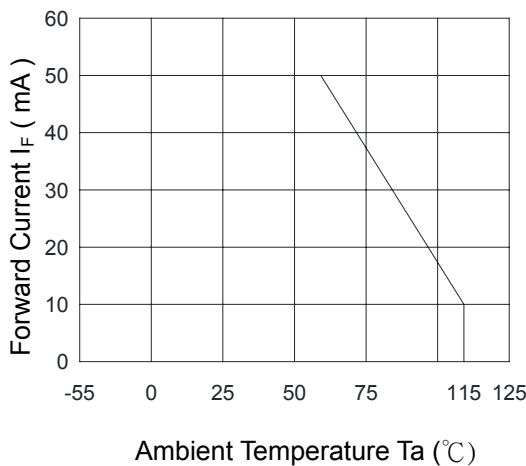

**Fig.5 Forward Current vs. Forward Voltage**

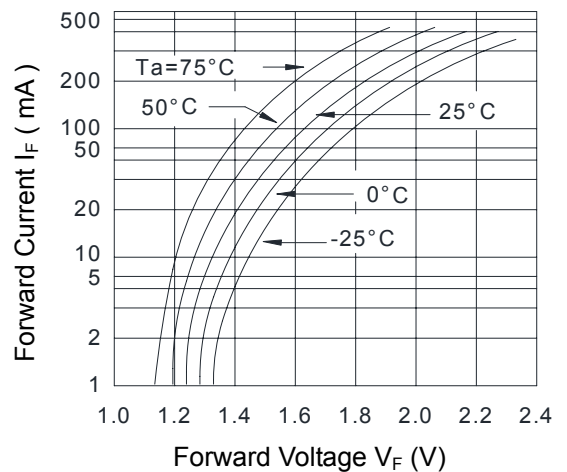

**Fig.6 Collector Current vs. Collector-Emitter Voltage**

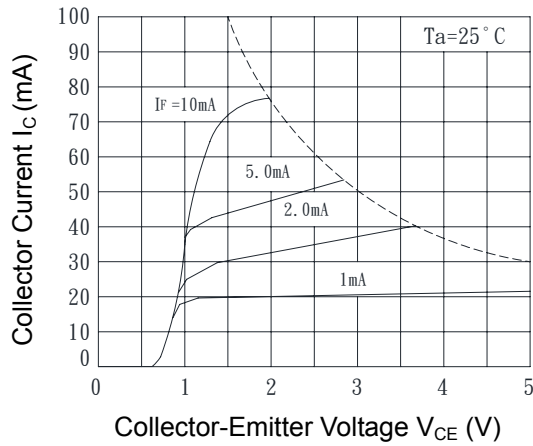

**Fig.7 Relative Current Transfer Ratio vs. Ambient Temperature**

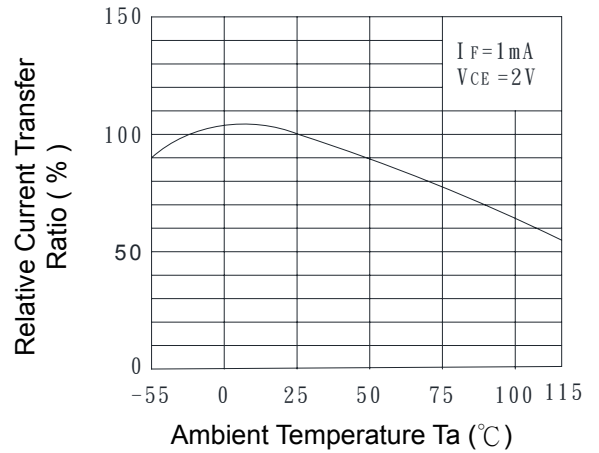

**Fig.8 Collector-Emitter Saturation Voltage vs. Forward Current**

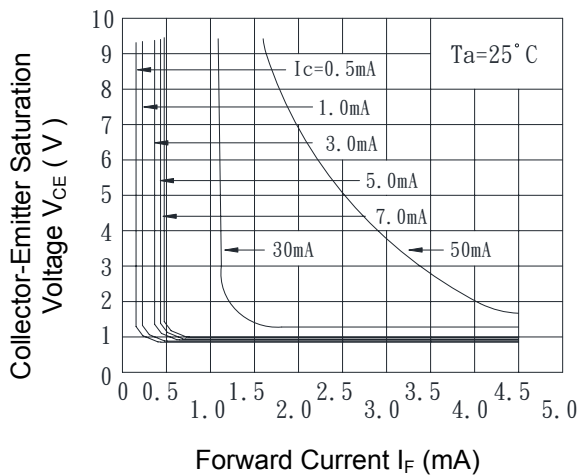

**Fig.9 Collector-Emitter Saturation Voltage vs. Ambient Temperature**

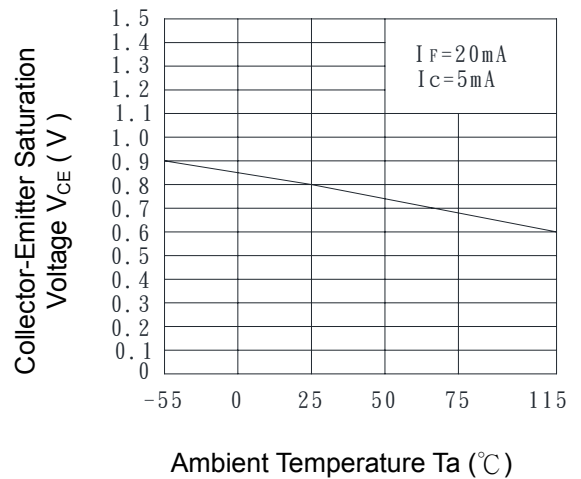

**Fig.10 Response Time vs. Load Resistance**

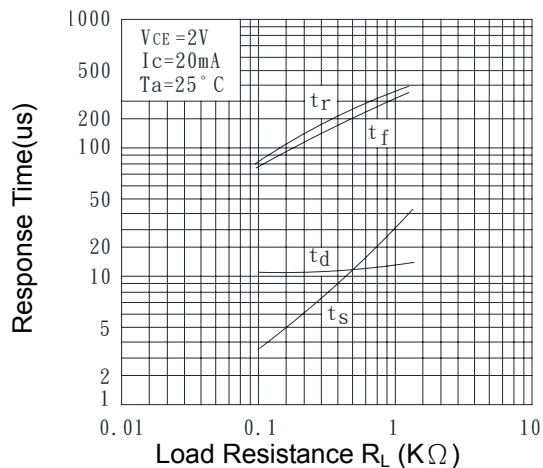

● **Test Circuit for Response Time**

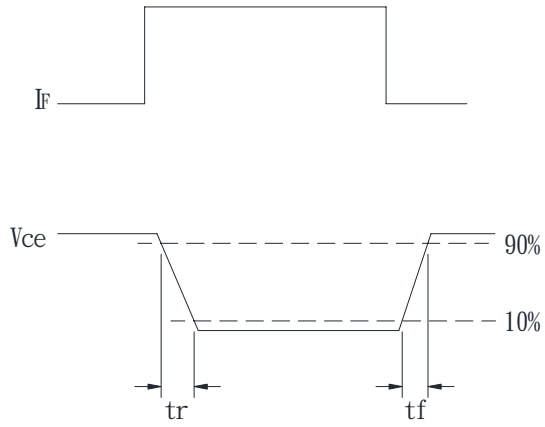
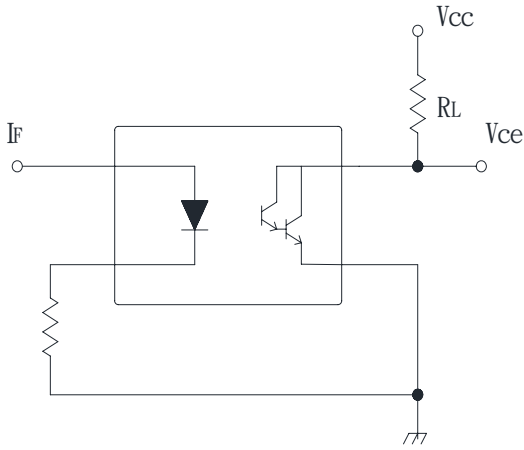

### ● Recommended Soldering Conditions

#### (a) Infrared reflow soldering :

- Peak reflow soldering : 260°C or below (package surface temperature)
- Time of peak reflow temperature : 10 sec
- Time of temperature higher than 230°C : 30-60 sec
- Time to preheat temperature from 180~190°C : 60-120 sec
- Time(s) of reflow : Two
- Flux : Rosin flux containing small amount of chlorine (The flux with a maximum chlorine content of 0.2 Wt% is recommended.)

#### Recommended Temperature Profile of Infrared Reflow

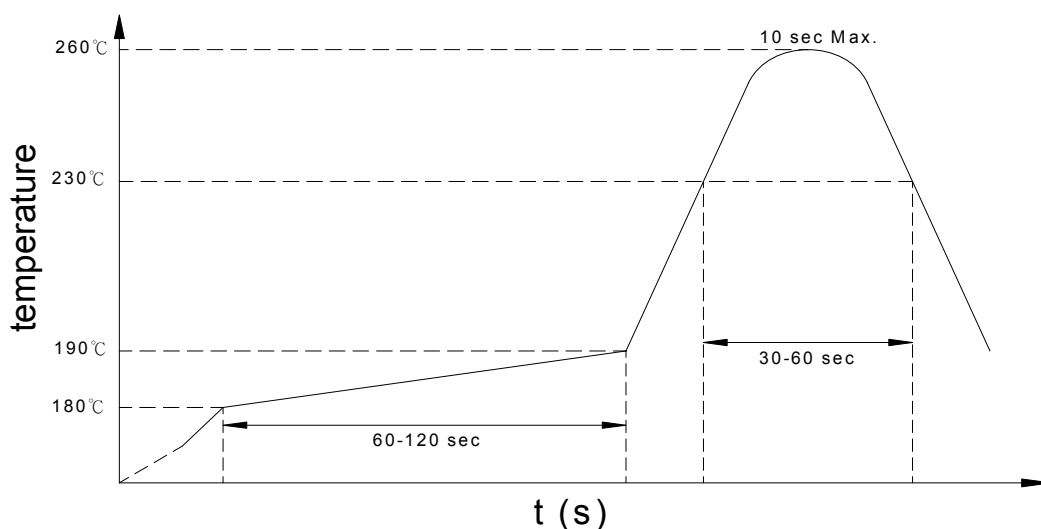

#### (b) Wave soldering :

- Temperature : 260°C or below (molten solder temperature)
- Time : 10 seconds or less
- Preheating conditions : 120°C or below (package surface temperature)
- Time(s) of reflow : One
- Flux : Rosin flux containing small amount of chlorine (The flux with a maximum chlorine content of 0.2 Wt% is recommended.)

#### (c) Cautions :

- Fluxes : Avoid removing the residual flux with freon-based and chlorine-based cleaning solvent.
- Avoid shorting between portion of frame and leads.

- **Numbering System**

### KPC825 X Y (Z)

**Notes:**

KPC825 = Part No.

X = Lead form option (0,S,H,L)

Y = CTR rank ( E )

Z = Tape and reel option (TL,TR,TLD,TRU)

Option	Description	Packing quantity
S (TL)	surface mount type package + TL tape & reel option	1000 units per reel
S (TR)	surface mount type package + TR tape & reel option	1000 units per reel
L (TLD)	long creepage distance for surface mount type package + TLD tape & reel option	1000 units per reel
L (TRU)	long creepage distance for surface mount type package + TRU tape & reel option	1000 units per reel

- **Recommended Pad Layout for Surface Mount Lead Form**

1.Surface mount type.

8 pin SMD

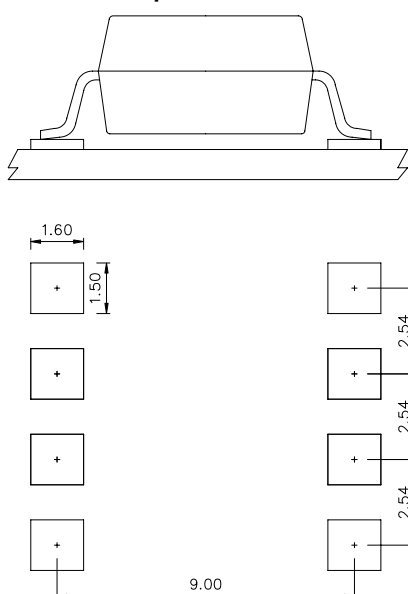

2.Long creepage distance for surface mount type.

8 pin L

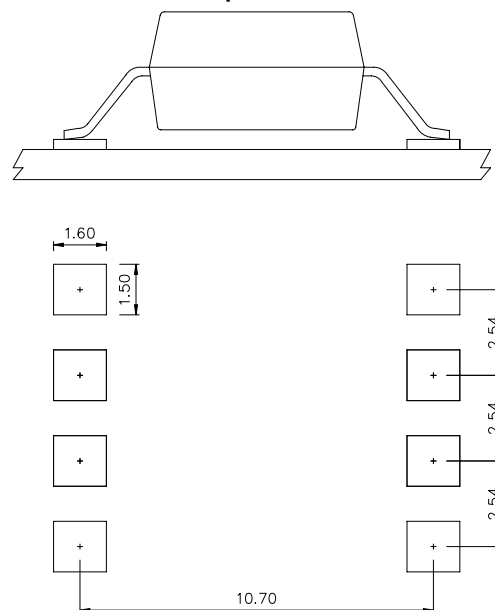

Unit : mm

<http://www.cosmo-ic.com>

● **8-pin SMD Carrier Tape & Reel**

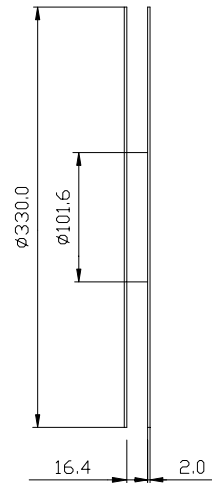
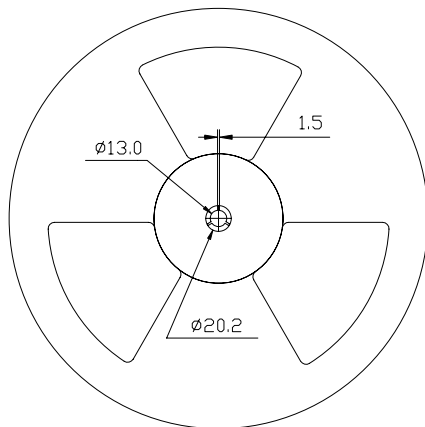
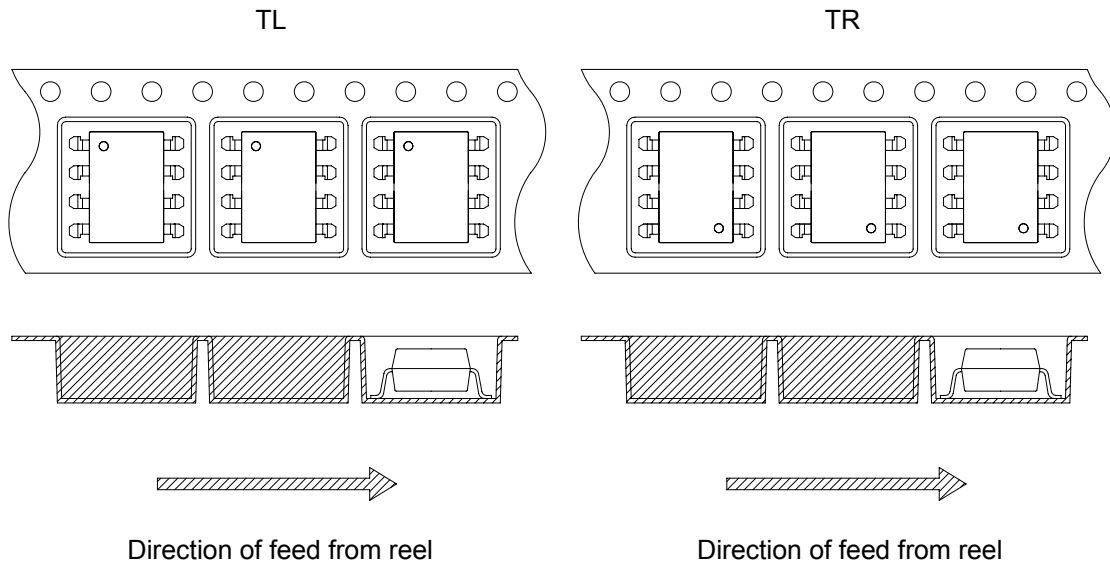
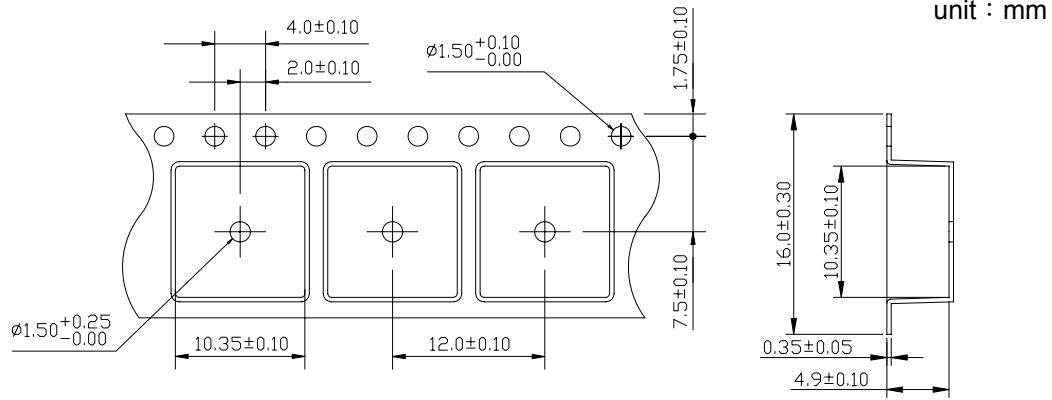

● 8-pin L Carrier Tape & Reel

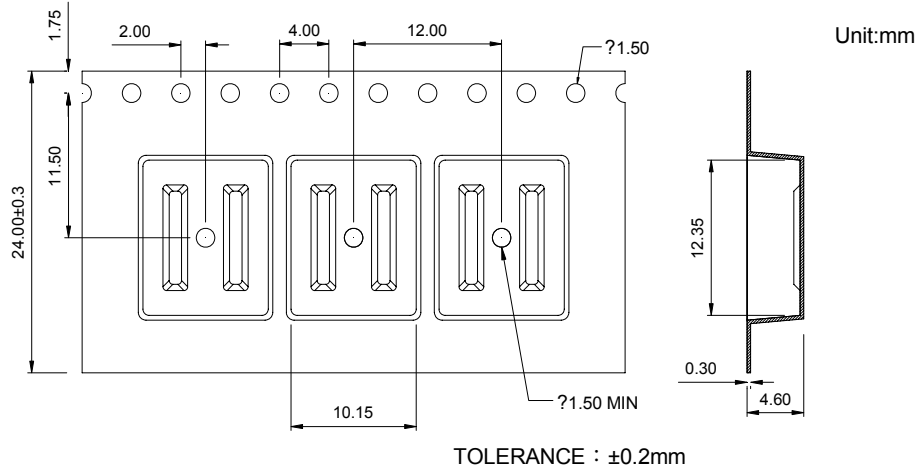

TLD

TRU

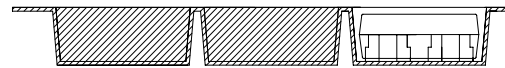
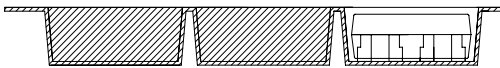
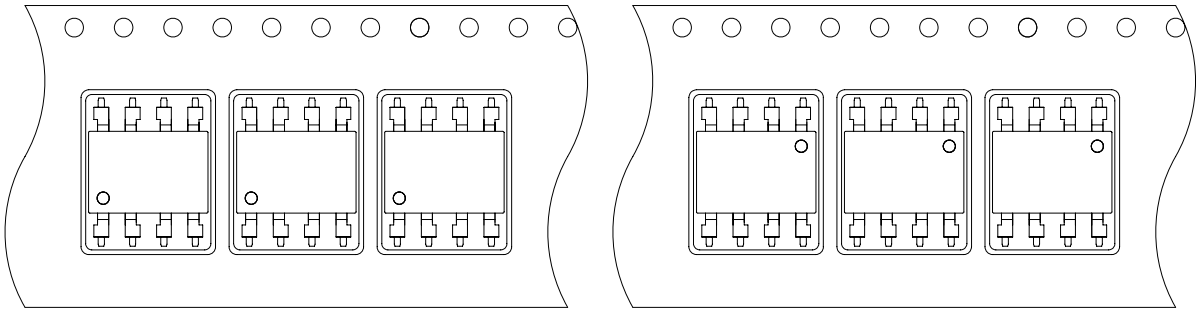

Direction of feed from reel

Direction of feed from reel

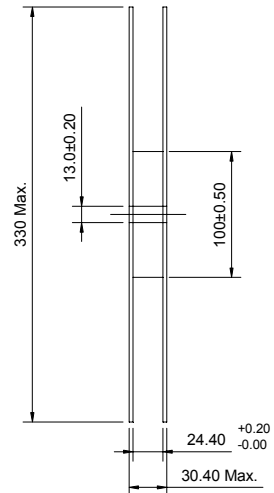
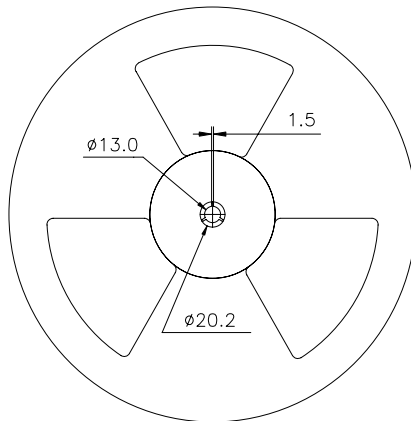



● **Application Notice**

The content of datasheet is the guidance for product use only. cosmo takes no responsibility to the accuracy of the information provided here. For continuously improving all of products, including quality, reliability, function...etc., cosmo reserves the right to change the specification, characteristics, data, materials, and structure of products without notice. Please contact with cosmo to obtain the latest specification.

It would be required to comply with the absolute maximum ratings listed in the specification. cosmo has no liability and responsibility to the damage caused by improper use of the products.

cosmo products are intended to be designed for use in general electronics application list below:

- a. Personal computer
- b. OA machine
- c. Audio / Video
- d. Instrumentation
- e. Electrical application
- f. Measurement equipment
- g. Consumer electronics
- h. Telecommunication

cosmo devices shall not be used or related with equipment requiring higher level of quality / reliability, or malfunction, or failure which may cause loss of human life, bodily injury, includes, without limitation:

- a. Medical and other life supporting equipments
- b. Space application
- c. Telecommunication equipment (trunk lines)
- d. Nuclear power control
- e. Equipment used for automotive vehicles, trains, ships...etc.

This publication is the property of cosmo. No part of this publication may be reproduced or copied in any form or any means electronically or mechanically for any purpose, in whole or in part without any written permission expressed from cosmo.