

# PRODUCT SPECIFICATION

DATE: 05/20/2004

<b>cosmo</b> ELECTRONICS CORPORATION	SMD LED : <b>KL197T02</b>	NO. 61L03002	REV. 1
		SHEET 1 OF 9	

## Features

**Package:** 1.6x0.8x0.6mm(0603) standard package

**Feature of the device:** extremely wide viewing angle; ideal for backlighting and coupling in light guides

**Wavelength:** 640nm(ultra red),573nm(green), 470nm(blue)

**Viewing angle:** Extremely Wide( 130° )

**Grouping parameter:** luminous intensity

**Assembly methods:** suitable for all SMT assembly methods

**Soldering methods:** IR reflow soldering

**Taping:** Package in 8mm tape on 7" diameter reel

## Package Dimensions

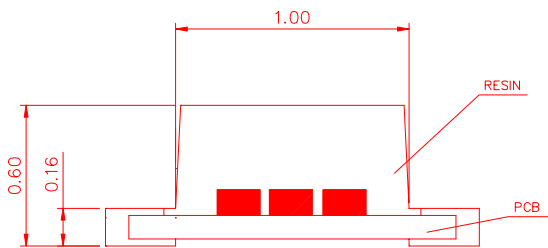
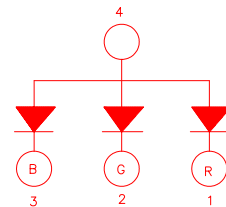
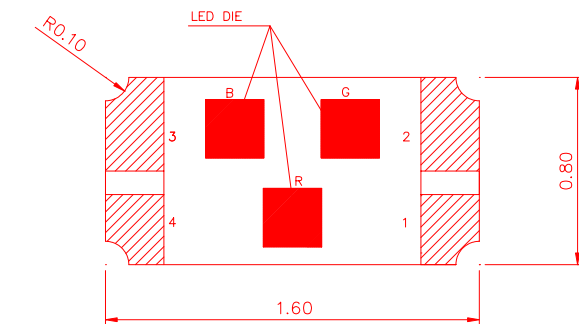

For reflow soldering

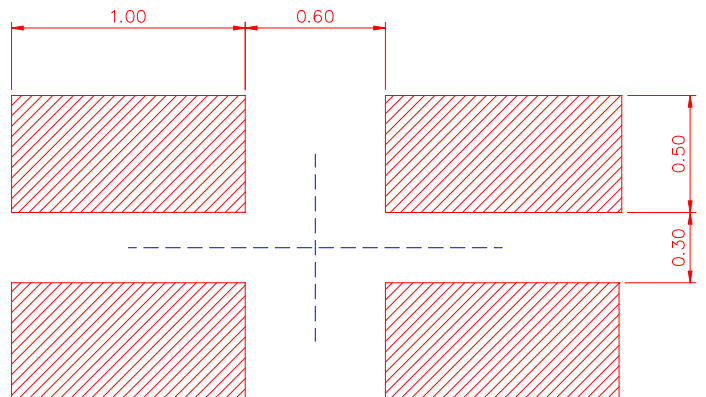
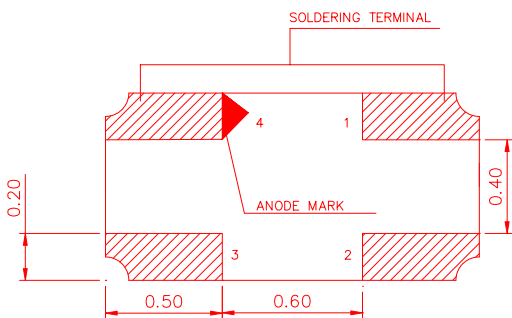

Unit: mm  
Tolerance:  $\pm 0.1$

# PRODUCT SPECIFICATION

DATE: 05/20/2004

<b>cosmo</b> ELECTRONICS CORPORATION	SMD LED : <b>KL197T02</b>	NO. 61L03002	REV. 1
		SHEET 2 OF 9	

## Absolute Maximum Ratings

At Ta = 25°C

Parameter	KL-197T02			Unit
Power Dissipation	R	G	B	mW
	72	72	80	
Peak Forward Current	100			mA
(1/10 Duty Cycle, 0.1ms Pulse Width)				
Forward Current	30			mA
Reverse Voltage	5			V
Operating Temperature Range	-25°C ~+ 80°C			
Storage Temperature Range	-30°C ~+ 85°C			
Wave Soldering Condition	240°C For 10 Seconds			

# PRODUCT SPECIFICATION

DATE: **05/20/2004**

<b>cosmo</b> ELECTRONICS CORPORATION	SMD LED :	NO. 61L03002	REV.
	<b>KL197T02</b>	SHEET 3 OF 9	<b>1</b>

## Electrical & Optical Characteristics

At Ta = 25°C

Parameter	Symbol	PART NO	Min.	Typ.	Max.	Unit	Test Condition
Luminous Intensity	Ultra Red	KL-197T02	70	80	-	mcd	IF = 20mA Note 1
	Green		150	170	-		
	Blue		30	50	-		
Viewing Angle	$2\theta_{1/2}$	Ultra Red/ Blue/Green	-	130	-	deg	Note 2
Dominant Wavelength	$\lambda_d$	Ultra Red	-	630	-	nm	IF = 20mA Note 3
		Green	-	525	-		
		Blue	-	470	-		
Spectral Line Half-Width	$\Delta\lambda$	Ultra Red	-	20	-	nm	-
		Green	-	35	-		
		Blue	-	30	-		
Forward Voltage	VF	Ultra Red	-	1.9	2.4	V	IF = 20mA
		Green	-	3.0	3.5		
		Blue	-	3.5	4.0		
Reverse Current	Ir	Ultra Red/ Blue/Green	-	-	100	$\mu$ A	VR = 5V

Note :

- Luminous intensity is measured with a photo detector and filter combination that follows the CIE etc - response curve. And the equipment measured luminous intensity tolerance is  $\pm 5\%$ .
- $\theta_{1/2}$  is the off - axis angle at which the luminous intensity is half the axial luminous intensity.
- The dominant wavelength,  $\lambda_d$  is derived from the CIE chromaticity diagram and represents the color of the device.
- Caution in ESD:  
Static Electricity maybe cause damages to the LED. It is recommend to use a wrist band or anti - electrostatic glove when handing the LED.  
All devices, equipment and machinery must be properly grounded.

# PRODUCT SPECIFICATION

DATE: 05/20/2004

<b>cosmo</b> ELECTRONICS CORPORATION	SMD LED : <b>KL197T02</b>	NO. 61L03002	REV. 1
		SHEET 4 OF 9	

## The Reliability criteria of SMD LED

Item	Symbol	Test Condition	Limit	
			Min	Max
Forward Voltage	VF	IF=10mA	-	U.S.L*1.2
Reverse Current	IR	VR=5V	-	U.S.L*2.0
Power	PO	IF=10mA	L.S.L*0.7	-

\*U.S.L: Upper Standard Level

\*L.S.L: Lower Standard Level

## Results of Reliability Test

NO	Item	Test Condition	Test Hours/Cycles	Sample NO	Ac / Re
1	Temperature Cycle	H: +100°C 30min ∫ 5min L: -40°C 30min	100CYCES	11 PCS	0 / 1
2	High Temperature Storage	Temp : 100°C	500HRS	11 PCS	0 / 1
3	Low Temperature Storage	Temp : -40°C	500HRS	11 PCS	0 / 1
4	DC Operating Life	IF: 20mA	500HRS	11 PCS	0 / 1
5	High Temperature / High Humidity	60°C / 90% RH	500HRS	11 PCS	0 / 1

# PRODUCT SPECIFICATION

DATE: 05/20/2004

<b>cosmo</b> ELECTRONICS CORPORATION	SMD LED : <b>KL197T02</b>	NO.61L03002	REV. 1
		SHEET 5 OF 9	

## Typical Electro-Optical Characteristics Curves

Relative spektrale Emission  $I_{rel}=f(\lambda)$ ,  $T_a=25^\circ\text{C}$ ,  $I_F=10\text{mA}$

$V(\lambda)$ =Standard eye response curve

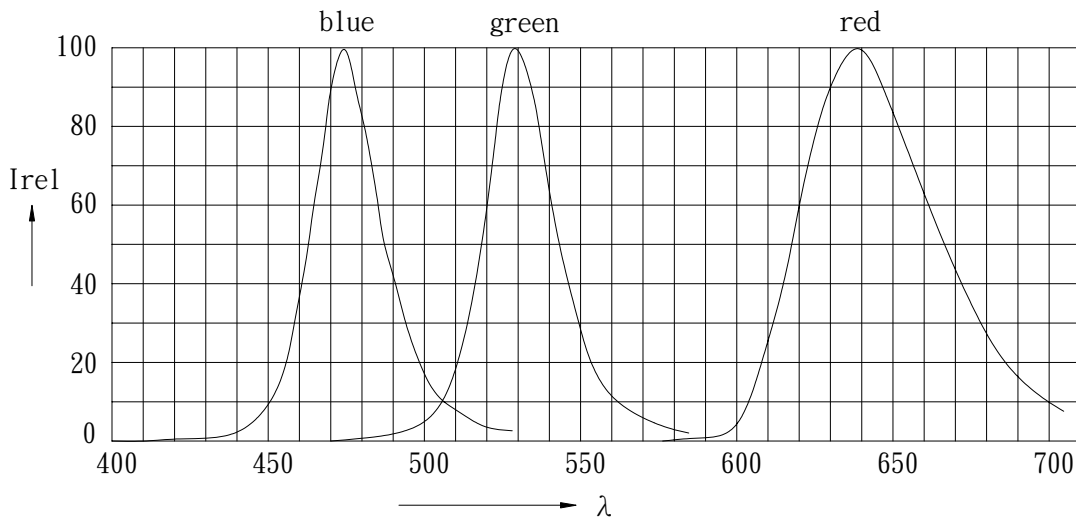

Forward Current  $I_F=f(V_F)$ ,  $T_A=25^\circ\text{C}$

Relative Luminous Intensity  $I_v/I_v(10\text{mA})=f(I_F)$   
 $T_A=25^\circ\text{C}$

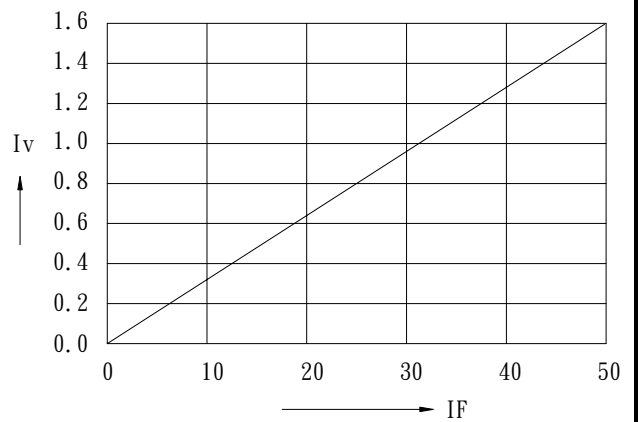
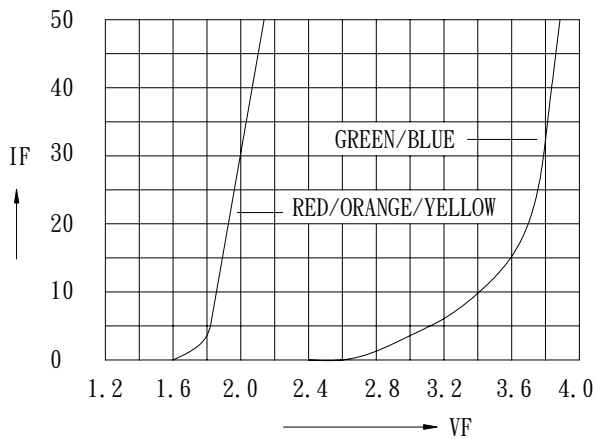

# PRODUCT SPECIFICATION

DATE: 05/20/2004

<b>cosmo</b> ELECTRONICS CORPORATION	SMD LED : <b>KL197T02</b>	NO. 61L03002	REV. 1
		SHEET 6 OF 9	

Max. Permissible Forward Current  $I_F=f(T_a)$

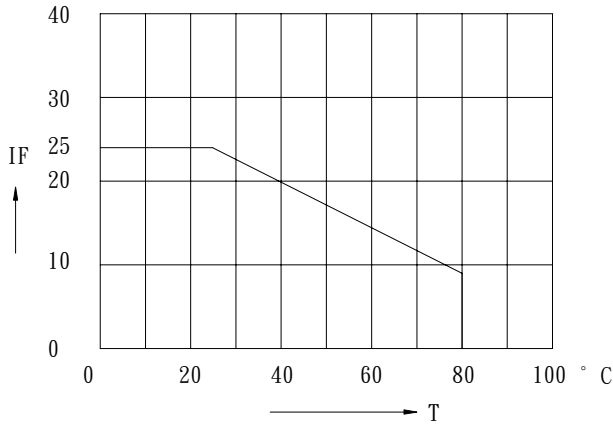

Radiation Characteristic  $I_{rel}=f(\phi)$

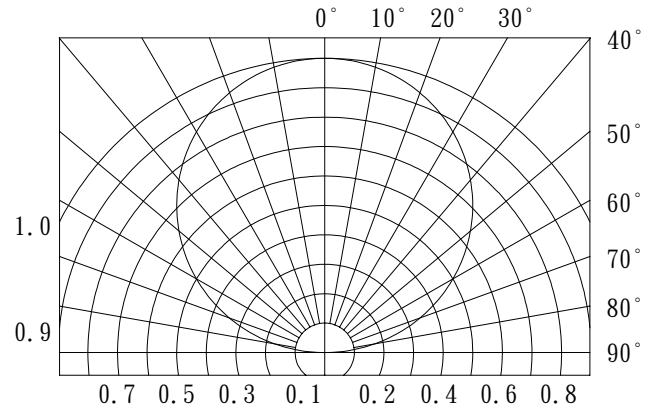

## Method of Taping / Polarity and Orientation

Packing unit 3000/reel

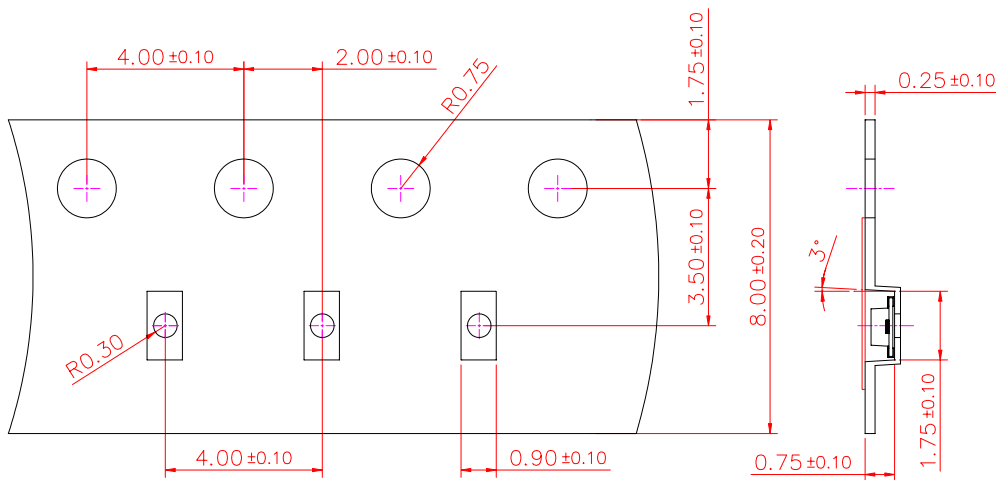

Unit : mm

Direction

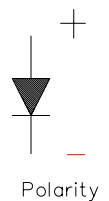
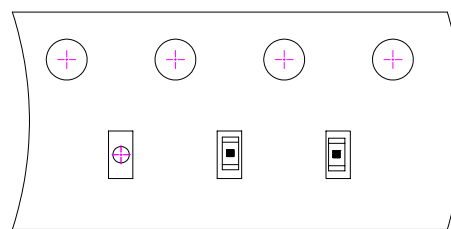
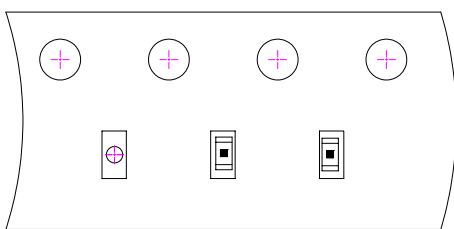

U: Taping upward

D: Taping downward

Notes: All dimensions are in millimeters (inches)

# PRODUCT SPECIFICATION

DATE: 05/20/2004

<b>cosmo</b> ELECTRONICS CORPORATION	SMD LED :	NO. 61L03002	REV.
	<b>KL197T02</b>	SHEET 7 OF 9	1

## Package Dimensions of Reel

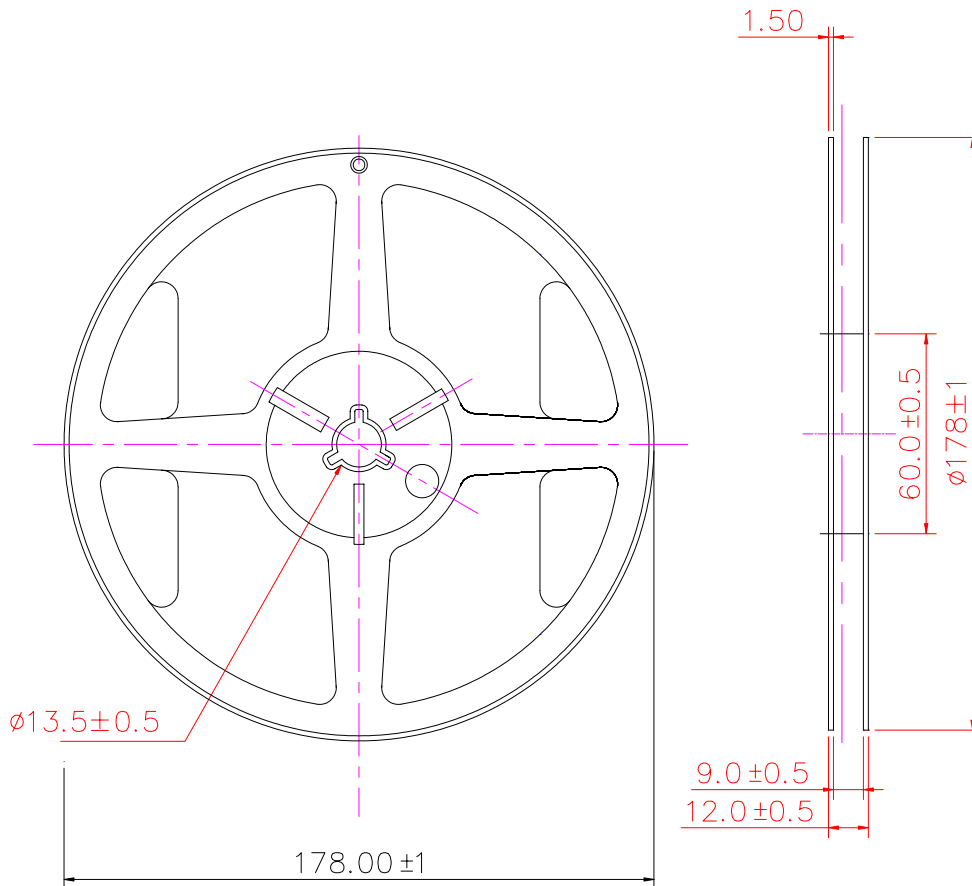

Unit: mm

## Packaging

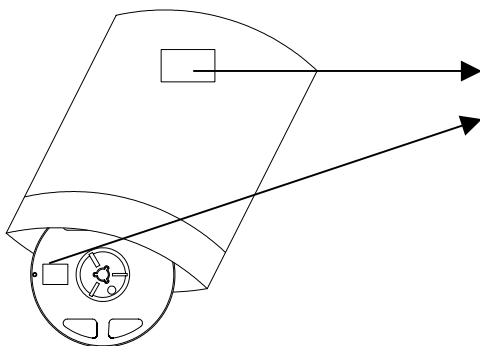

## Product lable

CUSTOMER:
CUSTOMER P/N:
DEVICE TYPE:
BIN:
COLOR RANK:
LOT NO:
QTY:

CAUTION: After open the aluminum laminate bag the lamps should be storage in the Follow condition

Temperautre: 5 to 30 °C, Humidity: 70%, Storage time: 72hrs max

Backing condition : If backing is necessary , we recommended the backing condition is 60 +/- 5°C  
10hours

# PRODUCT SPECIFICATION

DATE: 05/20/2004

<b>cosmo</b> ELECTRONICS CORPORATION	SMD LED : <b>KL197T02</b>	NO. 61L03002	REV. 1
		SHEET 8 OF 9	

## Packing

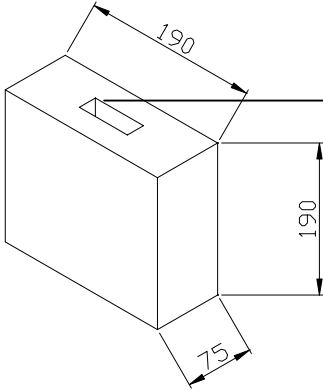

CUSTOMER:  
CUSTOMER P/N:  
DEVICE TYPE:  
BIN:  
COLOR RANK:  
LOT NO:  
QTY:

## Cautions for use

### Over-current-proof

Customer must apply resistors for protection ,others slight voltage shit will cause big current change (Burn out will happen).

### Storage time

The operation of temperature and RH are :  $5^{\circ}\text{C}\sim 35^{\circ}\text{C}$  ,RH60%.

Once the package is opened , the products should be used within a week.

Otherwise , they should be kept in a damp proof box with descanting agent.

Considering the tape life , we suggest our customers to use our products within a year(from production date)

If opened more than one week in an atmosphere  $5^{\circ}\text{C}\sim 35^{\circ}\text{C}$  , RH60% , they should be treated at  $60^{\circ}\text{C} \pm 5^{\circ}\text{C}$  for 15 hrs.

COSMO-Innotek will not be held responsible for any damage to the user that may result from accidents or any other reasons during operation of the user's unit if use to exceed the absolute maximum ratings, or not keep the matters that demand special attention.

# PRODUCT SPECIFICATION

DATE: 05/20/2004

<b>cosmo</b> ELECTRONICS CORPORATION	SMD LED : <b>KL197T02</b>	NO. 61L03002	REV. 1
		SHEET 9 OF 9	

## Others

Soldering Heat Reliability

Available for Pb free soldering process

Please refer to the following figure :

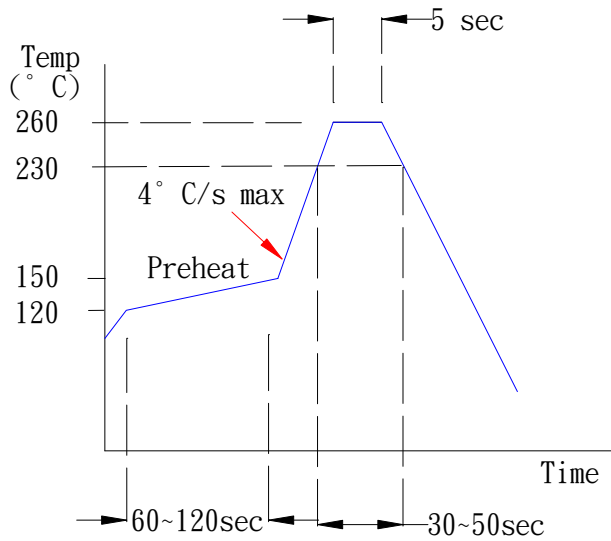

## Soldering Iron

Basic spec is  $\leq 5\text{sec}$  when  $260^{\circ}\text{C}$ . If temperature is higher, time shorter (  $+10^{\circ}\text{C} \rightarrow -1\text{sec}$  ). Power dissipation of Iron should be smaller than 15W, and temperature should be controllable. Surface temperature of the device should be under  $230^{\circ}\text{C}$ .

## Rework

Customer must finish rework within 5sec under  $245^{\circ}\text{C}$ .

The head of Iron can not touch copper foil.

Twin-head type is preferred.

