

ML58C88

CMOS BTL Drivers for DVD players

The ML58C88 is a five-channel CMOS BTL driver IC for driving the motors and actuators in DVD players or other applications. The ML58C88 has independent precision voltage regulators with adjustable range from 1.5V to 4 V.

❖ APPLICATION

BTL. Driver for CD,CD-ROM and DVD.

❖ FEATURES

- Two channels are voltage-type BTL drivers for actuators of tracking and focus. Two channels are voltage-type BTL driver for sled and spindle motors. It is also built-in one channel bi-direction DC motor driver for tray.
- Wide dynamic range [4.5V (typ.) when $V_{cc1} = V_{cc2} = 5V$, at $R_L = 20\Omega$ load].
- Separating power of V_{cc1} and V_{cc2} is to improve power efficiency by a low supply voltage for tracking, focus and spindle.
- Level shift circuit built-in.
- Thermal shut down circuit built-in.
- Dual actuator drivers:
A general purpose input OP provides differential input for signal addition. The output structure is two power OPAMPs in bridge configuration.
- Sled motor driver :
A general purpose input OP provides differential input for signal addition. The output structure is one power OPAMP in bridge configuration.
- Spindle driver:
Single input linear BTL driver. The output structure are two power OPAMPs in bridge configuration.
- Tray in-out driver:
The DC motor driver supports forward/reverse control for tray motor.
- 2 Built-in regulator controllers:
Adjustment range 1.5V ~ 4V

❖ ABSOLUTE MAXIMUM RATINGS (Ta = 25 °C)

Parameter	Symbol	Limits	Unit
Supply Voltage	Vcc1 Vcc2	6	V
Power dissipation	Pd	1.7*	W
Operate Temp Range	T opr	-35 ~ +85	°C
Storage Temp range	Tstg	** -55 ~ +150	°C

* When mounted on a 70mmx70mmx1.6mm glass epoxy board
 ** Reduced by 13.6mW for each increase in Ta of 1°C over 25°C
 ** Should not exceed Pd or ASO and Tj =150°C values.

❖ OPERATING CONDITIONS (Ta = 25 °C)

Parameter	Symbol	Limits	Unit
Supply Voltage	Vcc1	2.5 ~ 5.5	V
	Vcc2	2.5 ~ Vcc1	V

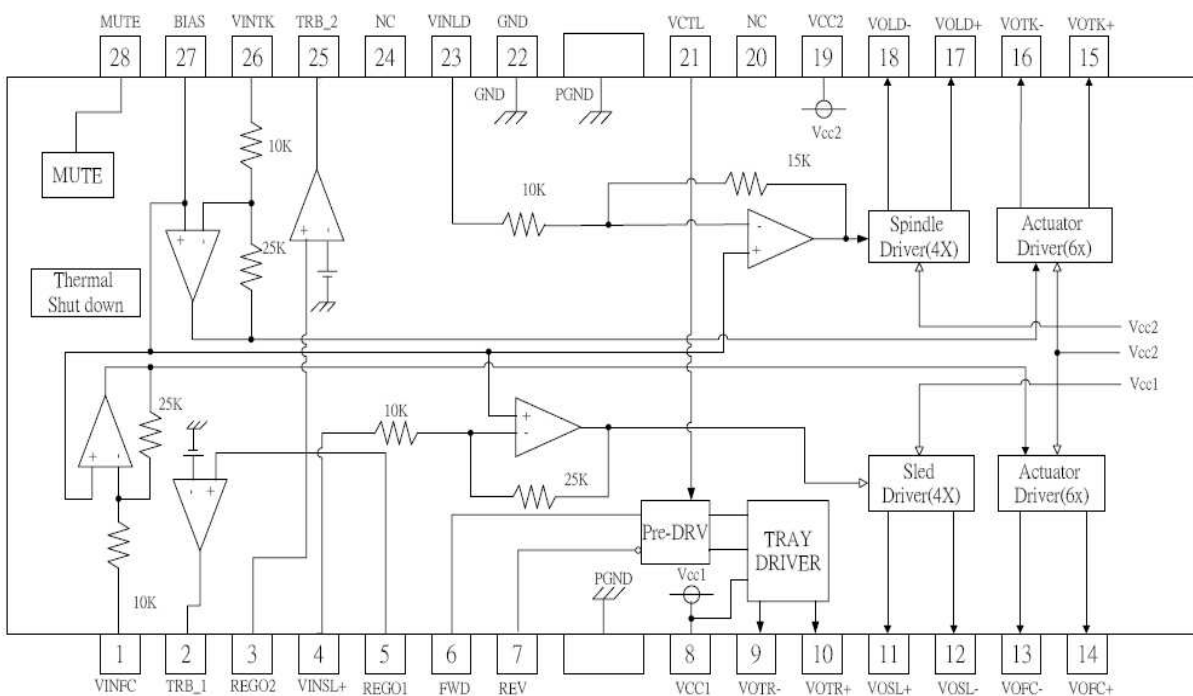
❖ BLOCK DIAGRAM

❖ ELECTRICAL CHARACTERISTICS

(Unless otherwise specified Ta=25°C, VCC1=VCC2=5V, BIAS=2.5V, RL=8Ω/10Ω/20Ω/45Ω)

PARAMETER	Symbol	CONDITIONS	MIN	TYPE	MAX	UNITS
Quiescent Current	Icc		5	15	25	mA
Voltage for mute ON	Vston		--	--	0.5	V
Voltage for mute OFF	Vstoffs		1.5	--	--	V
< Actuator drivers >						
Output offset voltage	Voo		--	--	± 50	mV
Maximum output	Vom	@10Ω Load	3.3	4.0	--	V
Voltage gain	Gv	VIN=BIAS+0.2Vpp ac @1KHz	21.5	23.5	25.5	dB
< Sled motor driver >						
Output offset voltage	Voofs1		--	--	±100	mV
Maximum output	Voms1	@20Ω Load	3.5	4.0	--	V
Closed loop voltage gain	Gvs1	VIN=BIAS+0.2Vpp ac @1KHz	18	20	22	dB
< Spindle motor driver >						
Output offset voltage	Voofld		--	--	±50	mV
Maximum output	Vomax	@8Ω Load	--	3.5	--	V
Voltage gain	Gvld	VIN=BIAS+0.2Vpp ac @1KHz	13.3	15.5	17.5	dB
Gain error by polarity	△Gvld	VIN=BIAS+0.2Vpp ac @1KHz				dB
< Tray motor driver >						
Output saturation voltage 1	VSAT1	Upper + Lower saturation, IL=200mA	--	1.1	1.5	V
Output saturation voltage between F & R	△VSAT1	Output saturation voltage 1 between FWD and REV	--	--	0.1	V
Output saturation voltage 2	VSAT2	Upper + Lower saturation, IL=500mA	1.0	1.55	2.2	V
< Tray motor driver input logic >						
Input Threshold	VTH		0.5	--	1.5	V
Pull Down Resistor	RL		--	200	--	kΩ
< Regulator > **						
Output voltage	Vreg	IL=500mA ***	1.5		4.0	V
Output load differential	△VRL	IL=500mA	-50	0	50	mV
Power supply voltage differential	△V VCC	(Vcc=4.5 ~8V) IL=500mA	-25	0	25	mV

* This device is not designed for protection against radioactive rays.

** It is based on 8550C PNP application.

*** It is based on 8550D

❖ **PIN CONFIGURATION**

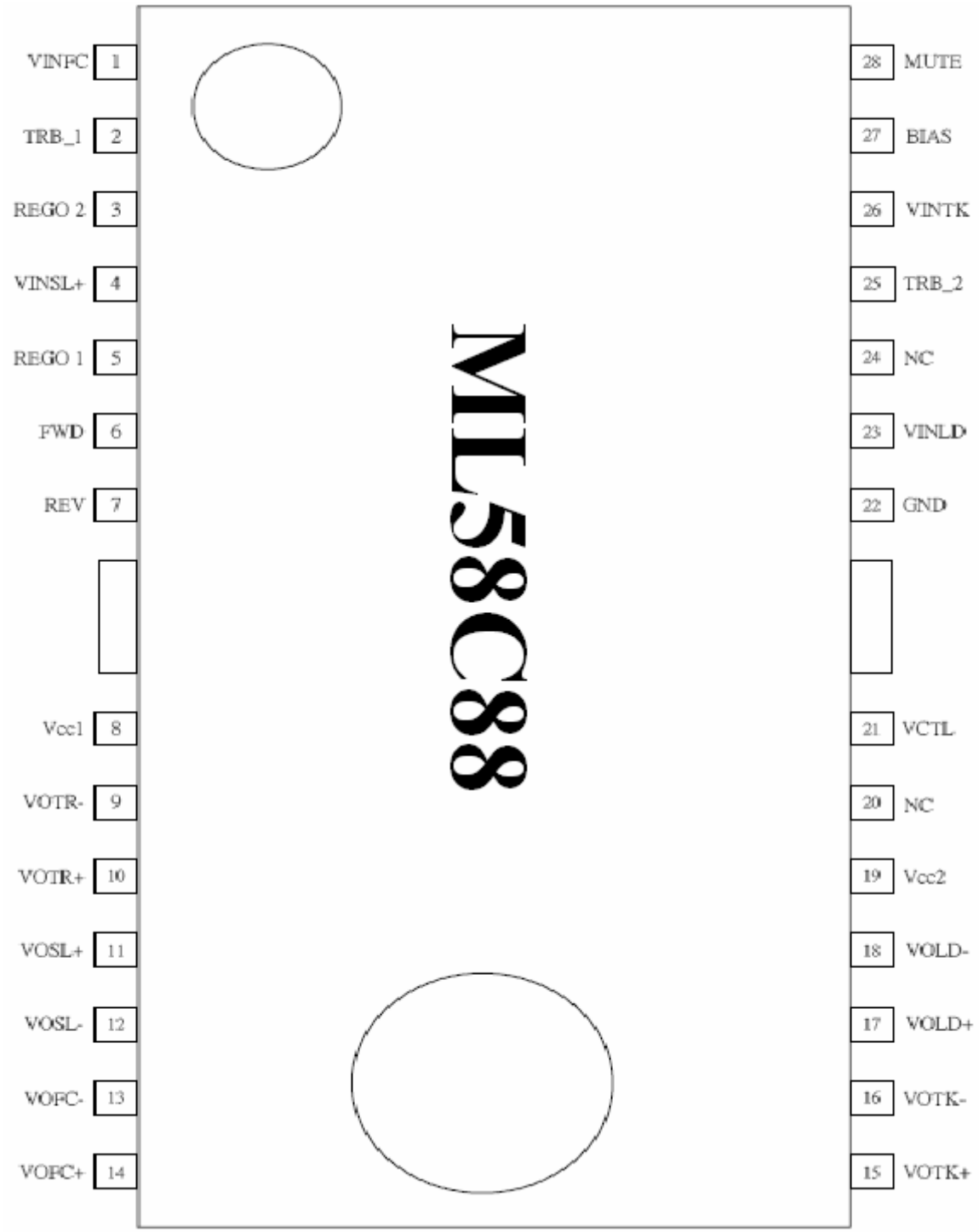

❖ **PIN DESCRIPTION**

PIN No.	Pin Name	Function
1	VINFC	Input for focus driver
2	TRB 1	Connect to external transistor base
3	REGO2	Regulator voltage output, connect to external
4	VINSL +	Input for the sled driver
5	REGO1	Regulator voltage output, connect to external
6	FWD	Tray driver forward input
7	REV	Tray reverse forward input
8	Vcc1	Vcc for pre-drive block and power block of sled
9	VOTR-	Tray driver output (-)
10	VOTR+	Tray driver output (+)
11	VOSI +	Sled driver output (+)
12	VOSI -	Sled driver output (-)
13	VOFC-	Focus driver output (-)
14	VOFC+	Focus driver output (+)
15	VOTK+	Tracking driver output (-)
16	VOTK-	Tracking driver output (+)
17	VOLD+	Spindle driver output (+)
18	VOLD-	Spindle driver output (-)
19	Vcc2	Vcc for power block of spindle , tracking and focus
20	Nc	No Connection
21	VCTL	Speed control input of tray driver
22	GND	Ground
23	VINLD	Input for spindle driver
24	Nc	No Connection
25	TRB 2	Connect to external transistor base
26	VINTK	Input for tracking driver
27	BIAS	Input for reference voltage
28	MUTE	Input for mute control

Notes) Symbol of + and - (output of drivers) means polarity to input pin.
 (For example, if voltage of pin 1 is high, pin 14 is high)

❖ **POWER DISSIPATION CURVE**

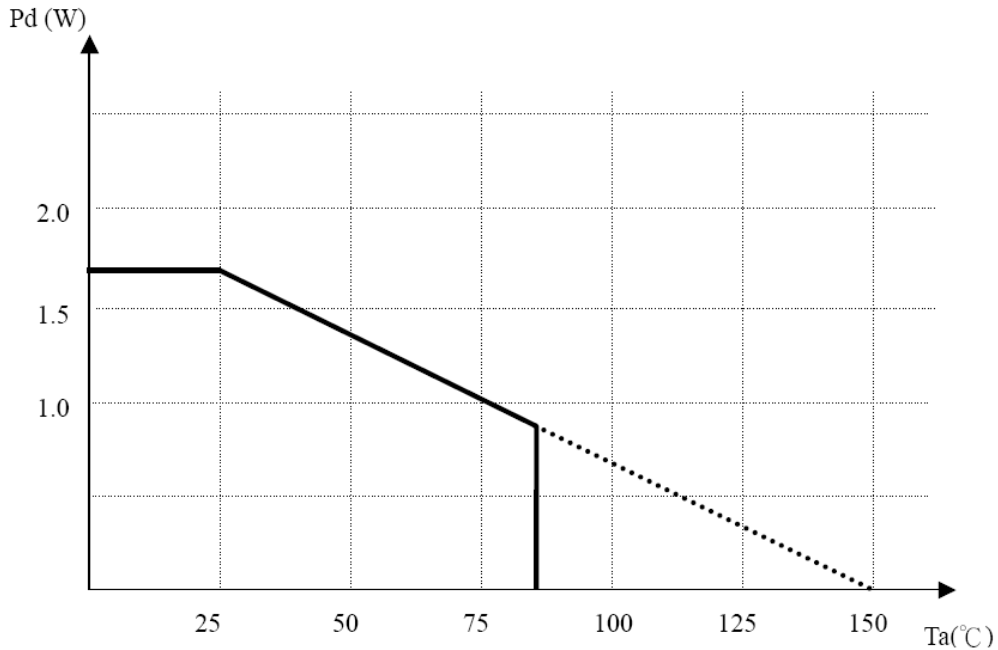

*70mm x 70mm x 1.6mm glass epoxy board
 *De-rating is done at 13.6mW/°C for operating above T= 25°C

❖ **OPERATION NOTES**

- 1) The built-in thermal shutdown circuit mutes the output current when the chip temperature reaches 175 °C (typ). The hysteresis is set to 25°C (typ.) ,so the circuit will start up again when the chip temperature falling to 150°C (typ.)
- 2) In case mute pin voltage is under 0.5V and NC, output current is muted (except for tray motor driver). Mute pin voltage should be more than 2.0V for normal application.
- 3) Bias pin (pin 27) should be pulled up more than 1.2V. In case the bias pin voltage is pulled down below 0.9V (typ.), the output current is muted.
- 4) Insert the bypass capacitor (~0.1uF) between Vcc pin and GND pin as close as possible.
- 5) Heat dissipation fins are attached to the GND on the inside of the package. Make sure to connect them to the external GND.
- 6) NC pins (20,24) are reserved for internal test. Please keep them floating.

7) Tray driver logic input:

FWD (pin 6)	REV (pin 7)	VOTR+(pin10)	VOTR- (pin 9)	Function
Quiescent Current	L	OPEN	OPEN	Open Mode
Voltage for mute ON	H	L	H	Reverse Mode
Voltage for mute OFF	L	H	L	Forward Mode
Output offset voltage	H	L	L	Brake Mode

Input circuit of pin 6 and pin 7 is designed to avoid simultaneous activation of upper and lower output it ; however, in order to improve reliability, apply motor forward/reserve input once through open mode. We recommend time period for open longer tan 10 sec.

"H" side Output voltage on output voltage (VOL+,VOL-) varies depending on output control thermal for tray (pin21). "H" side output voltage is set three times (9.2dB Typ.). VTCL(pin21). And. "L" side output voltage is equal to output saturation voltage.

❖ **APPLICATION CIRCUIT**

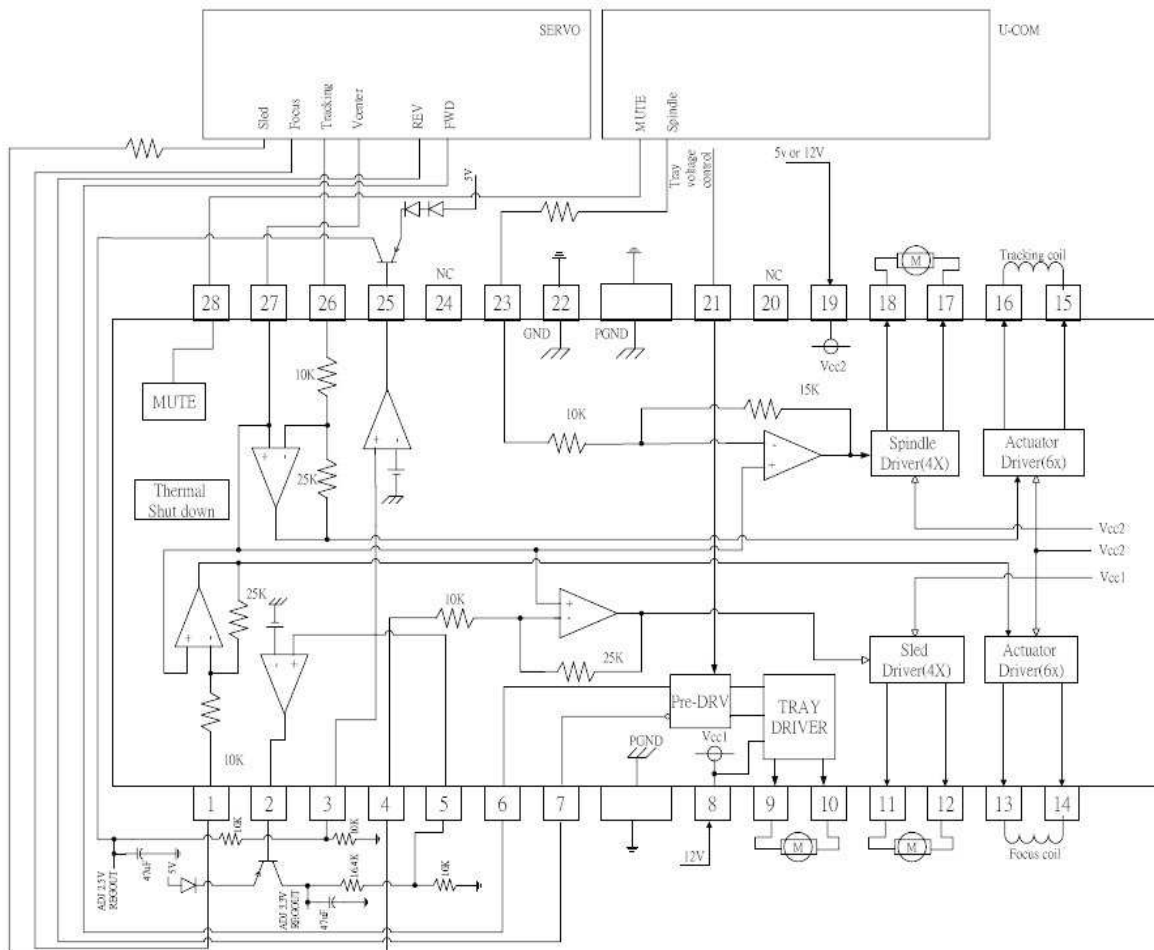

❖ **TEST & MEASUREMENT CIRCUIT**

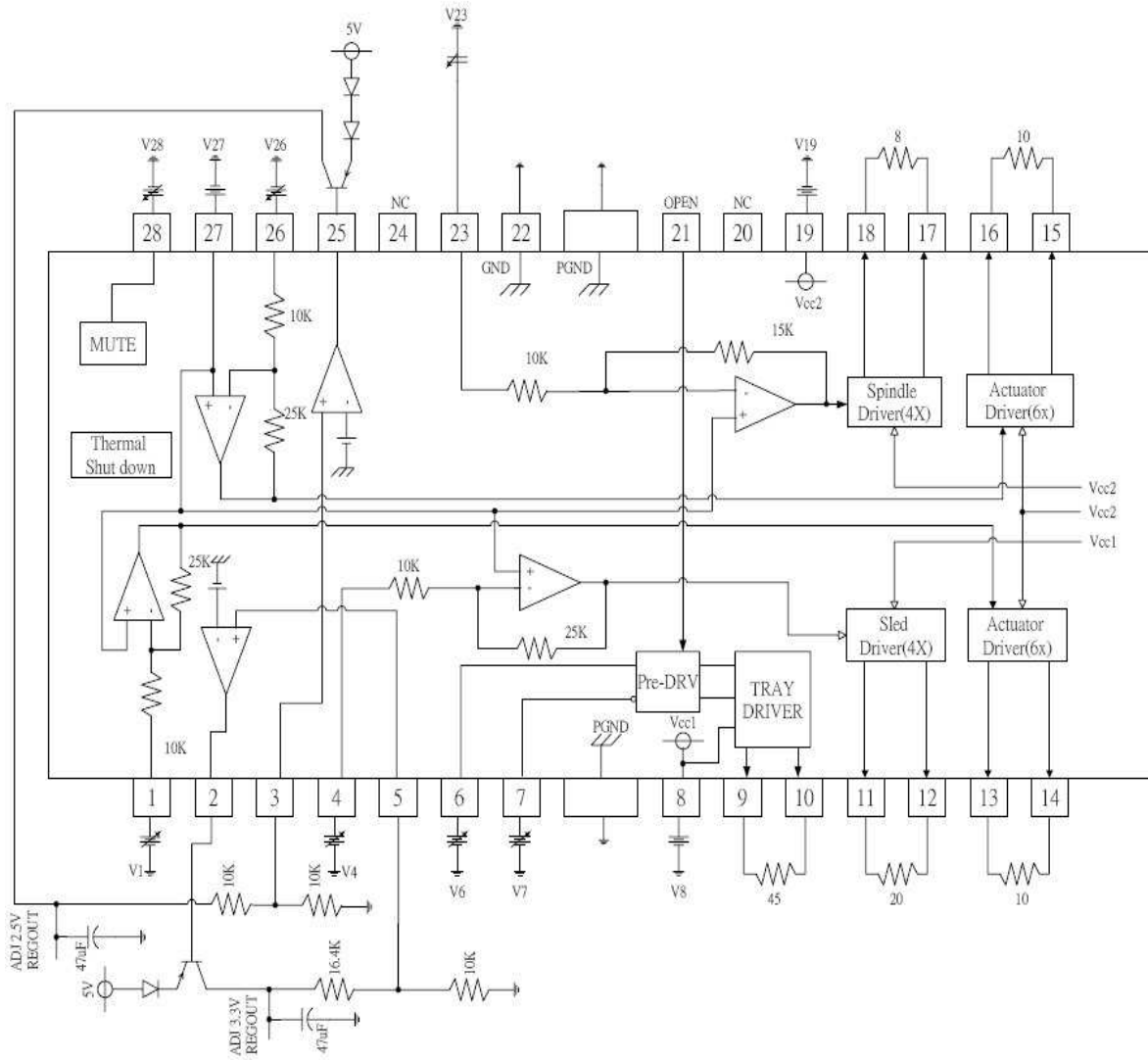

❖ **PACKAGE INFORMATION**

Package Type: HSOP28

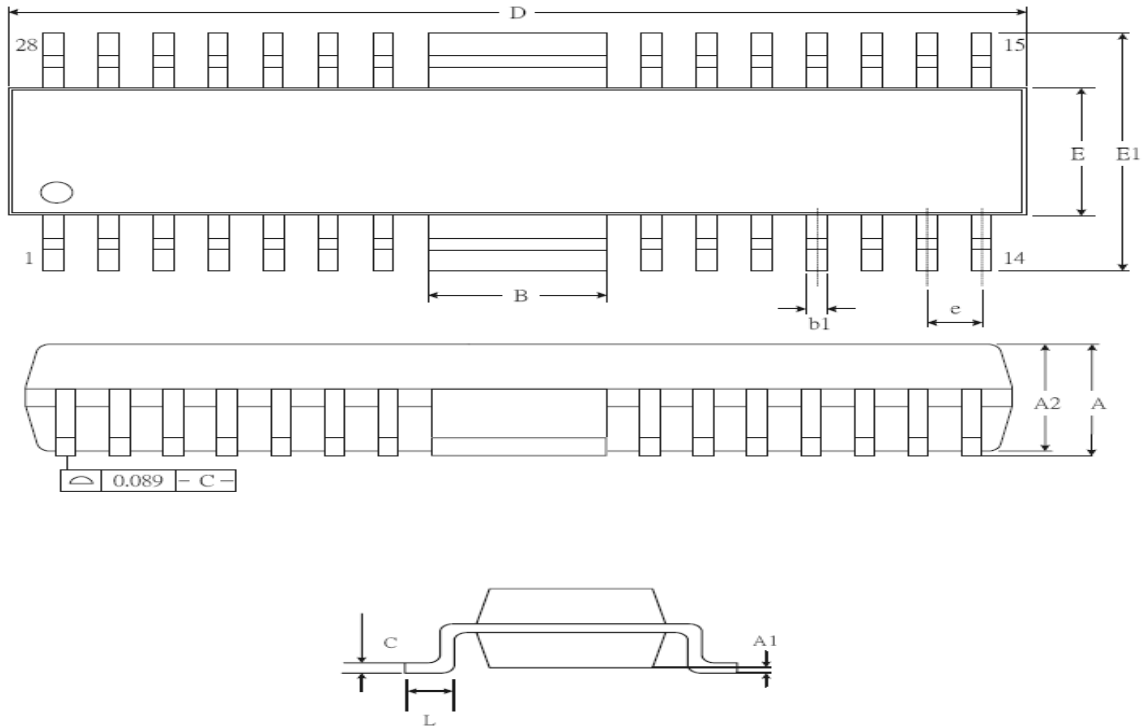

SYMBOL	MILLIMETERS		INCHES	
	MIN.	MAX.	MIN.	MAX.
A	--	2.75	--	0.108
A1	--	0.3	--	0.012
A2	--	2.45	--	0.096
B	4.95	5.35	0.195	0.211
b1	0.23	0.47	0.009	0.019
C	0.2	0.36	0.008	0.014
D	17.89	18.8	0.704	0.740
E	7.3	7.9	0.287	0.311
E1	9.6	10.65	0.378	0.419
e	0.8 (TYP)		0.031 (TYP)	
L	0.3	--	0.012	--

❖ **MARKING INFORMATION**

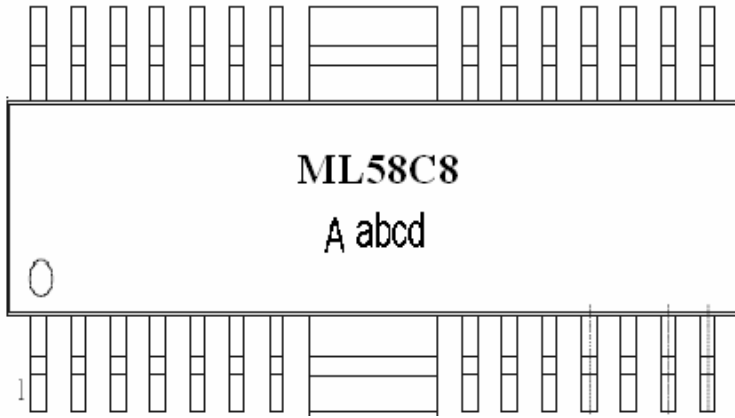

Designator	Description
ab	Year Code
cd	Week Code

For Example :

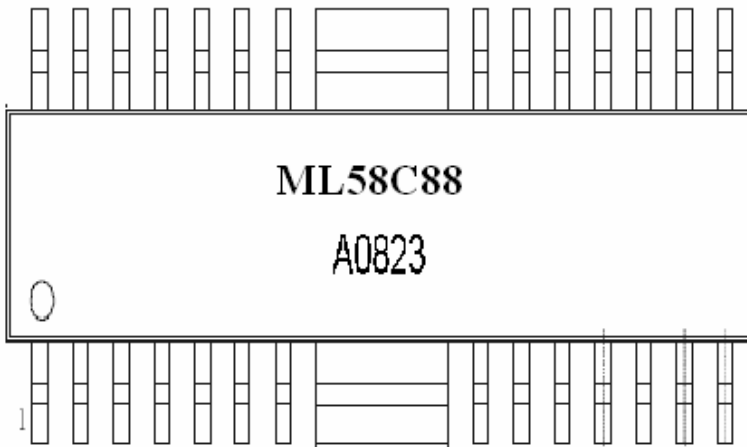

The information presented in this document does not form part of any quotation or contract, is believed to be accurate and reliable and may be changed without notice. No liability will be accepted by the publisher for any consequence of its use.