

- ◆ CMOS Dual 2-Input OR Gate
- ◆ Operating Voltage Range : 2V ~ 5.5V
- ◆ High Speed Operation : tpd = 3.8ns TYP
- ◆ Low Power Consumption : 1μA (max)
- ◆ MSOP-8A Package

■ Description

ML74WL32SRG is dual 2-input OR gate manufactured using silicon gate CMOS processes. The small quiescent current, which is one of the features of the CMOS logic, gives way to high speed operations which enables LS-TTL.

With wave forming buffers connected internally, stabilized output can be achieved as the series offers high noise immunity.

As the series is integrated into a mini molded, MSOP-8A package, high density mounting is possible.

■ Pin Configuration

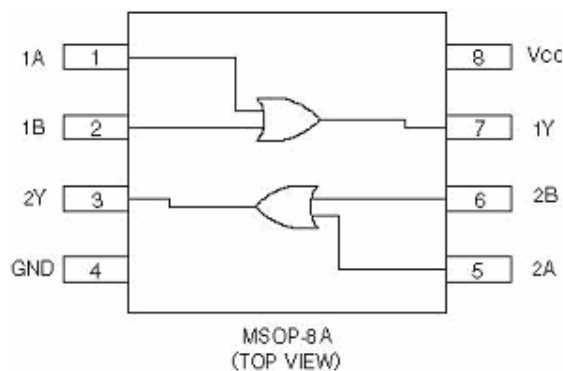

■ Absolute Maximum Ratings

Ta=-40°C~85°C

PARAMETER	SYMBOL	RATINGS	UNITS
Power Supply Voltage	Vcc	-0.5 ~ +6.0	V
Input voltage	VIN	-0.5 ~ +6.0	V
Output Voltage	VOUT	-0.5 ~ Vcc +0.5	V
Input Diode Current	I _{IK}	±20	mA
Output Diode current	I _{OK}	±20	mA
Output Current	I _{OUT}	±25	mA
Vcc, GND Current	I _{CC} , I _{GND}	±50	mA
Power Dissipation (Ta=25°C)	Pd	300	mW
Storage Temperature	T _{stg}	-65 ~ +150	°C

Note: Voltage is all Ground standardized.

■ Applications

- Palmtops
- Digital Equipment

■ Features

High Speed Operation : tpd = 3.8ns TYP (Vcc=5V)

Operating Voltage Range: 2V ~ 5.5V

Low Power Consumption: 1μA (max)

Small Package : MSOP-8A

■ Function

INPUT		OUTPUT
A	B	Y
H	H	H
H	L	L
L	H	L
L	L	L

H=High level

L=Low level

■ Recommended Operating Conditions

PARAMETER	SYMBOL	CONDITIONS	UNITS
Supply Voltage	V _{CC}	2 ~ 5.5	V
Input Voltage	V _{IN}	0 ~ 5.5	V
Output Voltage	V _{OUT}	0 ~ V _{CC}	V
Operating Temperature	T _{opr}	-40 ~ +85	°C
Input Rise / Fall Time	tr, tf	0 ~ 200 (V _{CC} =3.3V)	ns
		0 ~ 100 (V _{CC} =5V)	

■ DC Electrical Characteristics

PARAMETER	SYMBOL	V _{CC} (V)	CONDITIONS	Ta=25°C			Ta=-40~85°C		UNITS	
				MIN	TYP	MAX	MIN	MAX		
Input Voltage	V _{IH}	2.0		1.5	-	-	1.5	-	V	
		3.0		2.1	-	-	2.1	-		
		5.5		3.85	-	-	3.85	-		
	V _{IL}	2.0		-	-	0.5	-	0.5	V	
		3.0		-	-	0.9	-	0.9		
		5.5		-	-	1.65	-	1.65		
Output Voltage	V _{OH}	2.0	V _{IN} =V _{IL} or V _{IH}	I _{OH} =-50μA	1.9	2.0	-	1.9	-	V
		3.0			2.9	3.0	-	2.9	-	
		4.5			4.4	4.5	-	4.4	-	
		3.0			2.58	-	-	2.48	-	
		4.5			3.94	-	-	3.80	-	
	V _{OL}	2.0	V _{IN} = V _{IL}	I _{OL} =50μA	-	-	0.1	-	0.1	V
		3.0			-	-	0.1	-	0.1	
		4.5			-	-	0.1	-	0.1	
		3.0			-	-	0.36	-	0.44	
		4.5			-	-	0.36	-	0.44	
Input Current	I _{IN}	0~5.5	V _{IN} =V _{CC} or GND	-0.1	-	0.1	-1.0	1.0	μA	
Quiescent Supply Current	I _{CC}	5.5	V _{IN} =V _{CC} or GND, I _{OUT} =0μA	-	-	1.0	-	10.0	μA	

■ Switching Electrical Characteristics

PARAMETER	SYMBOL	CL	V _{CC} (V)	CONDITIONS	Ta=25°C			Ta=-40~85°C		UNITS
					MIN	TYP	MAX	MIN	MAX	
Propagation Delay Time	t _{PLH}	15pF	3.3		-	5.5	7.9	1	9.5	ns
			5.0		-	3.8	5.5	1	6.5	
		50pF	3.3		-	8	11.4	1	13	ns
			5.0		-	5.3	7.5	1	8.5	
	t _{PHL}	15pF	3.3		-	5.5	7.9	1	9.5	ns
			5.0		-	3.8	5.5	1	6.5	
		50pF	3.3		-	8	11.4	1	13	ns
			5.0		-	5.3	7.5	1	8.5	
Input Capacitance	C _{IN}	-	5.0	V _{IN} =V _{CC} or GND	-	2	10	-	10	pF
Power Dissipation Capacitance	C _{pd}	No Load, f=1MHz			-	8.9	-	-	-	pF

Tr=tf=3ns

■ Noise Characteristics

(tr=tf=3ns)

PARAMETER	SYMBOL	CL	Vcc(V)	CONDITIONS	Ta=25°C			UNITS
					MIN	TYP	MAX	
Not functioning output maximum dynamic VOL	VOLP	50pF	5.0		--	0.3	0.8	V
Not functioning output minimum dynamic VOL	VOLV	50pF	5.0		-0.8	-0.3	--	V
Minimum dynamic VIH	VIHD	50pF	5.0		--	--	3.5	V
Maximum dynamic VIL	VILD	50pF	5.0		--	--	1.5	V

■ Typical Application Circuit

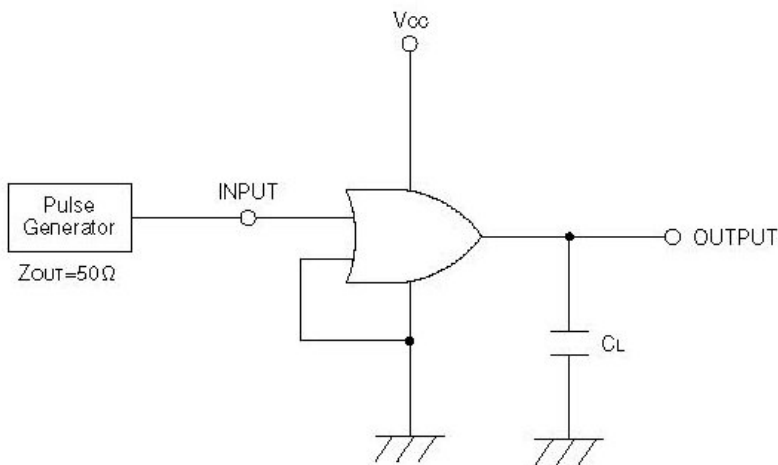

Note: Open output when measuring supply current

■ Waveforms

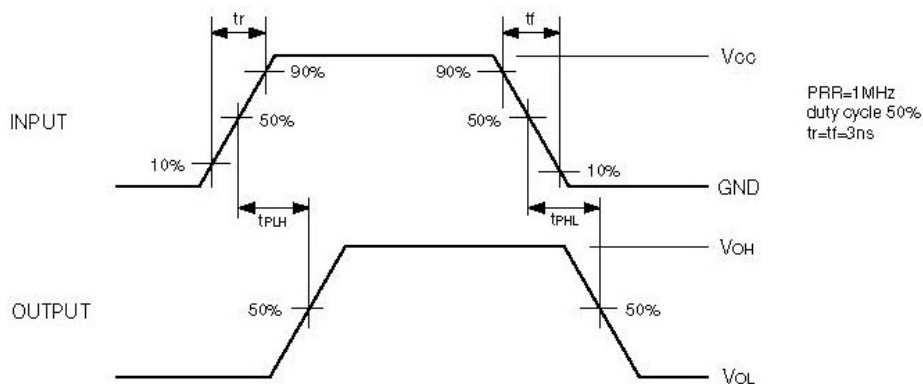

DISCLAIMER:

The information presented in this document does not form part of any quotation or contract, is believed to be accurate and reliable and may be changed without notice. No liability will be accepted by the publisher for any consequence of its use.