

- ◆ CMOS Logic Analog Switch/Multiplexer
- ◆ Operating Voltage Range : 2V ~ 5.5V
- ◆ High Speed Operation : tpd = 1.5ns TYP
- ◆ Low Power Consumption : 2μA (max)
- ◆ Low ON Resistance : Ron=22Ω TYP

■ Description

ML74UL4066MRG is an Analog Switch manufactured using silicon gate CMOS processes. The small quiescent current, which is one of the features of the CMOS logic, gives way to high speed operations which enables LS-TTL.

With wave forming buffers connected internally, stabilized output can be achieved as the series offers high noise immunity.

As the series is integrated into a mini molded, SOT-23-5 package, high density mounting is possible.

■ Pin Configuration

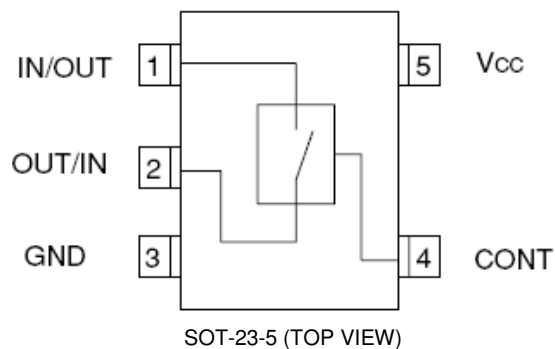

■ Logic Diagram

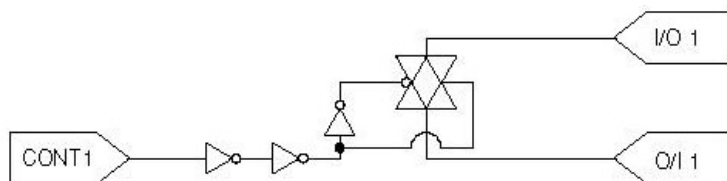

■ Applications

- Palmtops
- Digital Equipment

■ Features

High Speed Operation : tpd = 1.5ns TYP (Vcc=5V)

Operating Voltage Range: 2V ~ 5.5V

Low Power Consumption: 2μA (max)

Low ON Resistance : 22Ω TYP

Small Package : SOT-23-5

■ Function

Control	State
L	OFF
H	ON

H=High level

L=Low level

■ Absolute Maximum Ratings

Ta=-40°C~85°C

PARAMETER	SYMBOL	RATINGS	UNITS
Power Supply Voltage	Vcc	-0.5 ~ +6.0	V
Input voltage	VCONT	-0.5 ~ +6.0	V
Output Voltage	V _{i/o}	-0.5 ~ Vcc +0.5	V
Input Diode Current	I _{IK}	±20	mA
Output Diode current	I _{OK}	±20	mA
Switch Output Current	I _{i/o}	±25	mA
Vcc, GND Current	I _{CC} , I _{GND}	±50	mA
Power Dissipation (Ta=25°C)	P _d	300	mW
Storage Temperature	T _{stg}	-65 ~ +150	°C

Note: Voltage is all Ground standardized.

■ Recommended Operating Conditions

PARAMETER	SYMBOL	CONDITIONS	UNITS
Supply Voltage	Vcc	2 ~ 5.5	V
Input Voltage	V _{IN}	0 ~ 5.5	V
Output Voltage	V _{i/o}	0 ~ Vcc	V
Operating Temperature	T _{opr}	-40 ~ +85	°C
Input Rise / Fall Time	tr, tf	0 ~ 200 (Vcc=3.3V)	ns
		0 ~ 100 (Vcc=5V)	

■ DC Electrical Characteristics

PARAMETER	SYMBOL	Vcc(V)	CONDITIONS	Ta=25°C			Ta=-40~85°C		UNIT
				MIN	TYP	MAX	MIN	MAX	
"High" Level Control Input Voltage	V _{IH}	2.0		1.5	-	-	1.5	-	V
		3.0		2.1	-	-	2.1	-	
		5.5		3.85	-	-	3.85	-	
"Low" Level Control Input Voltage	V _{IL}	2.0		-	-	0.5	-	0.5	V
		3.0		-	-	0.9	-	0.9	
		5.5		-	-	1.65	-	1.65	
Peak ON Resistance	RONmax	2.0	VCONT=V _{IH}	-	130	350	-	550	Ω
		3.0	V _{IN} =0~Vcc	-	22	50	-	65	
		4.5	I _{IN} /O _{UT} =1mA	-	12	25	-	35	
ON Resistance	RON(1)	2.0	VCONT= V _{IH}	-	23	50	-	65	Ω
		3.0	V _{IN} = GND or Vcc	-	14	30	-	40	
		4.5	I _{IN} /O _{UT} =1mA	-	10	20	-	25	
Switch ON Resistance Differential	ΔRON	2.0	VCONT= V _{IH}	-	13	35	-	55	Ω
		3.0	V _{IN} =0~Vcc	-	3	6	-	8	
		4.5	I _{IN} /O _{UT} =1mA	-	2	4	-	6	
Power Off Leakage Current	I _{S(OFF)}	5.5	VCONT= V _{IL} , V _{IN} = Vcc or GND	-	-	±0.1	-	±1.0	μA
Power Off Leakage Current	I _{S(ON)}	5.5	VCONT= V _{IH} , V _{IN} = Vcc or GND	-	-	±0.1	-	±1.0	μA
Control Input Current	I _{CONT}	0~5.5	V _{IN} =Vcc or GND	-	-	±0.1	-	±1.0	μA
Quiscent Supply Current	I _{CC}	5.5	V _{IN} =Vcc or GND	-	-	2.0	-	20.0	μA

■ Switching Electrical Characteristics

 $T_r = t_f = 3\text{ns}$

PARAMETER	SYMBOL	CL	Vcc(V)	CONDITIONS	Ta=25°C			Ta=-40~85°C		UNITS	
					MIN	TYP	MAX	MIN	MAX		
Propagation Delay Time	tPHL	15pF	2.0		-	2.5	12	-	15	ns	
			3.3		-	2	4	-	5.5		
			5.0		-	1.5	3	-	4		
	tPHL	50pF	2.0		-	4	20	-	23	ns	
			3.3		-	3	6	-	8		
			5.0		-	2	5	-	6		
Output Enable Time	tZL	15pF	2.0	RL=1kΩ	-	8.5	45	-	60	ns	
			3.3		-	4.5	9	-	11		
			5.0		-	3.5	7.5	-	9		
	tZH	50pF	2.0		RL=1kΩ	-	9	50	-	65	ns
			3.3			-	5	10	-	12	
			5.0			-	4	8.5	-	10	
Output Disable Time	tLZ	15pF	2.0	RL=1kΩ		-	9	45	-	55	ns
			3.3			-	7	17	-	20	
			5.0			-	6	14	-	18	
	tHZ	50pF	2.0		RL=1kΩ	-	12	60	-	75	ns
			3.3			-	10	23	-	27	
			5.0			-	8	20	-	25	
Sine Wave Distortion Rate		50pF	3.0	RL=10kΩ fIN=1kHz		-	0.05	-	-	-	%
-3dB Band Width		50pF	3.0	RL=600kΩ $20\log_{10} \frac{V_{OUT}}{V_{IN}} = -3\text{dB}$		-	200	-	-	-	MHz
Feed Through (Switch-off)		50pF	3.0	RL=600kΩ		-	-60	-	-	-	dB
Cross Talk (Control Switch)		50pF	2.0	RL=600kΩ fCONT=1MHz	-	60	-	-	-	mV	
			3.0		-	100	-	-	-		
			4.5		-	150	-	-	-		
Cross Talk (between Switches)		50pF	2.0		RL=600kΩ fIN=1MHz	-	-60	-	-	-	dB
			3.0			-	-60	-	-	-	
			4.5			-	-60	-	-	-	
Control Input Capacitance	CCONT	-	-			-	5	10	-	10	pF
Switch Input/Output Capacitance	CIN/OUT	-	-			-	6	-	-	-	pF
Feed Through Capacitance	CIN-OUT	-	-			-	0.5	-	-	-	pF
Power Dissipation Capacitance	Cpd	-	-		-	13	-	-	-	pF	

■ ON Resistance

■ Typical Application Circuit

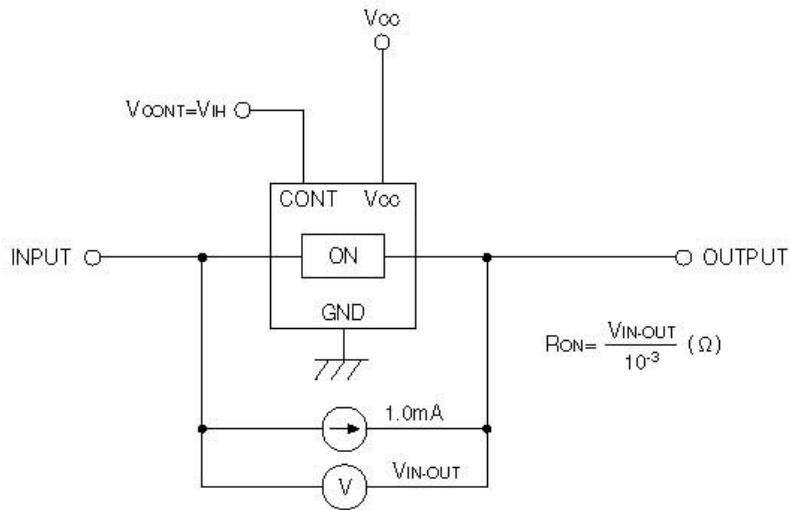

■ Voltage Dependancies of ON Resistance

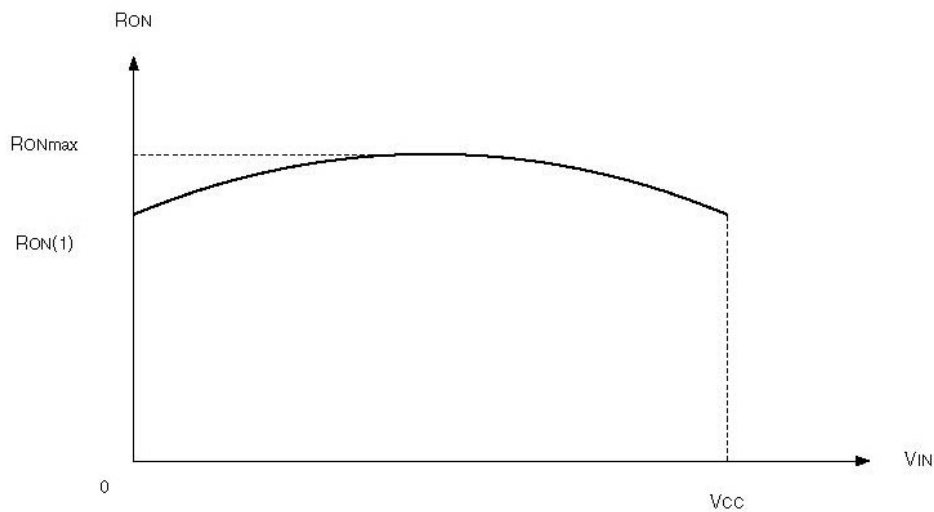

■ Power Off Leakage Current

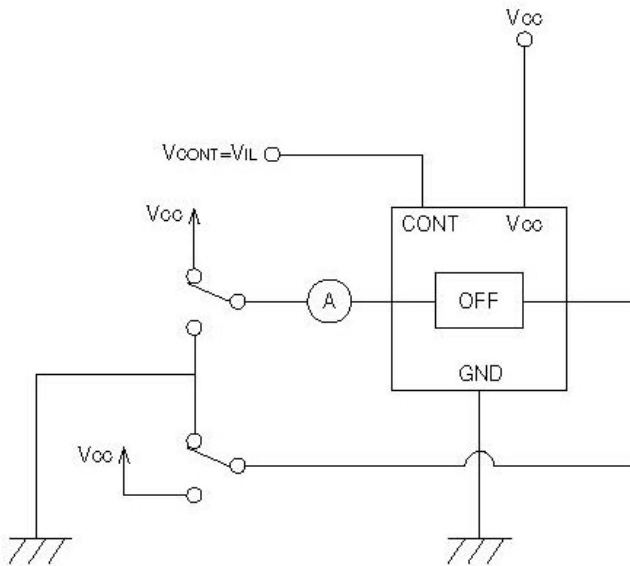

■ Power On Leakage Current

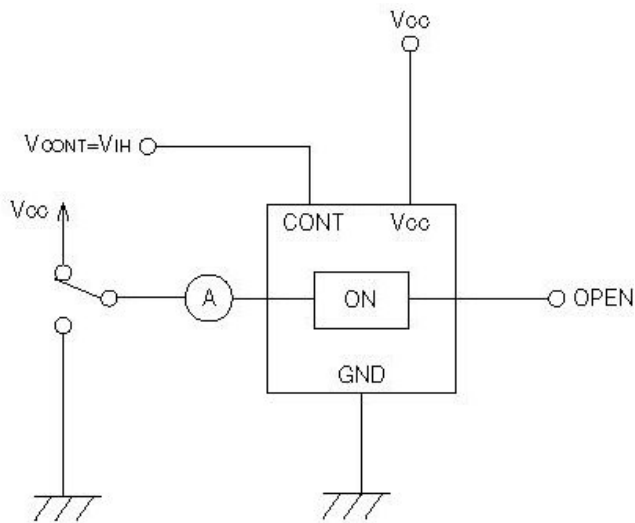

■ Propagation Delay Time

■ Typical Application Circuit

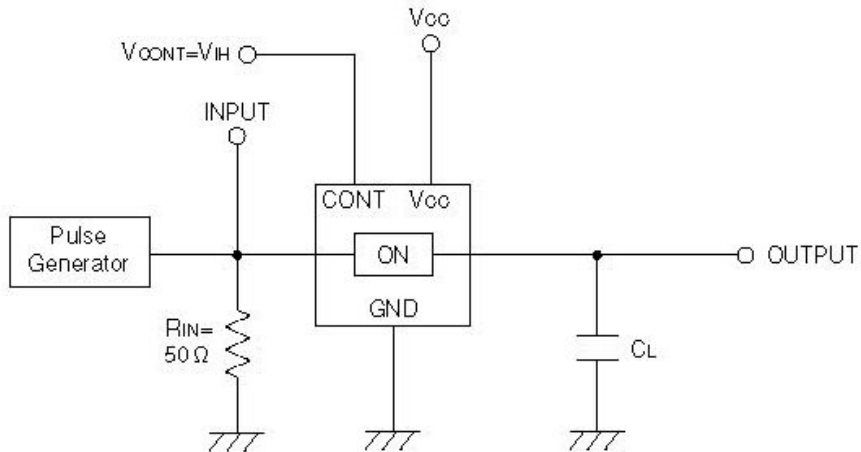

■ Waveforms

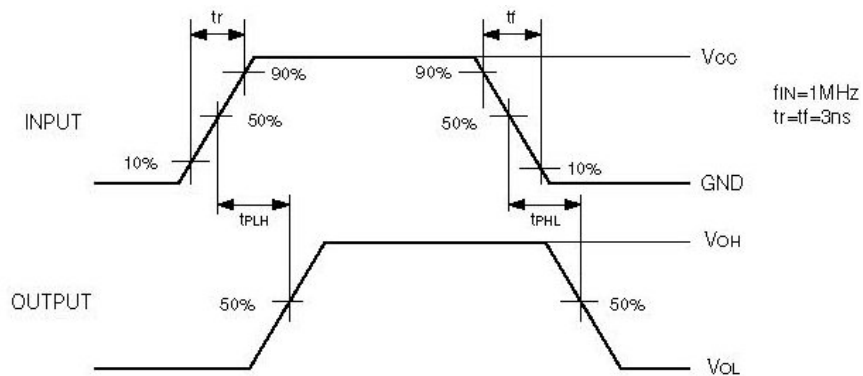

■ **Output Enable Time, Output Disable Time**

■ **Typical Application Circuit**

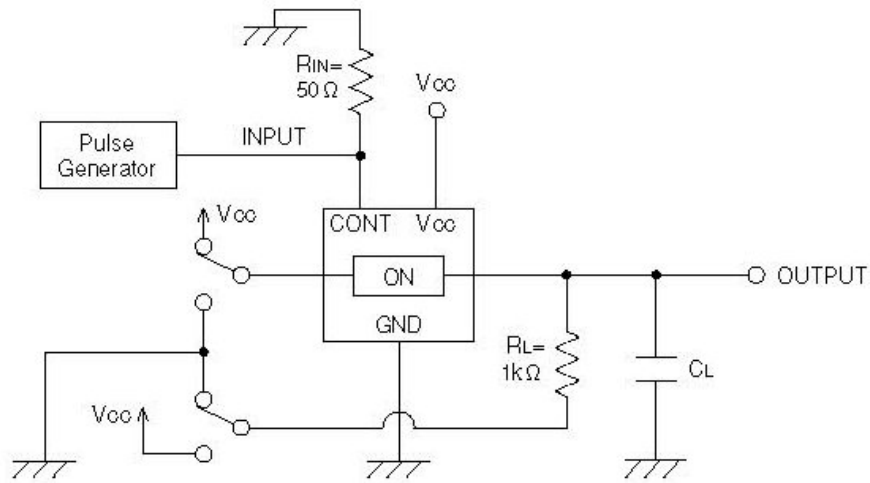

■ **Waveforms**

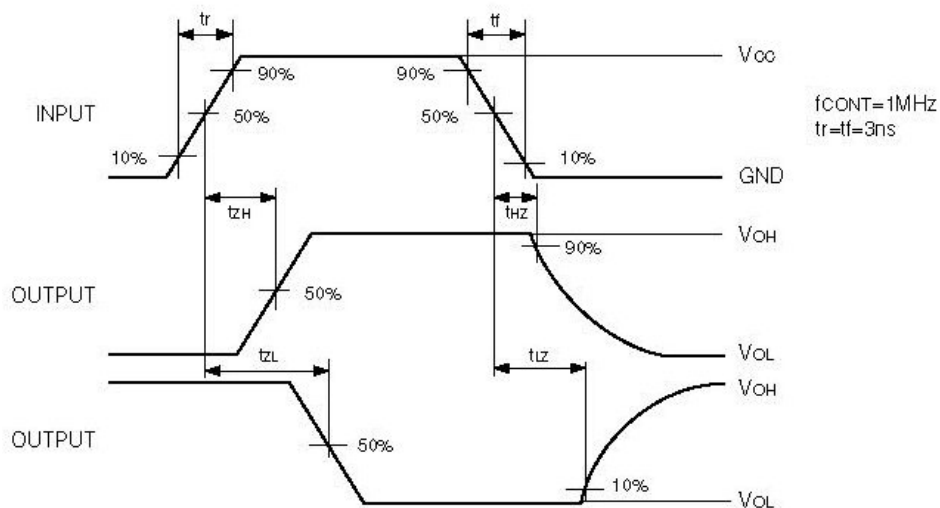

■ Sine Wave Distortion Rate

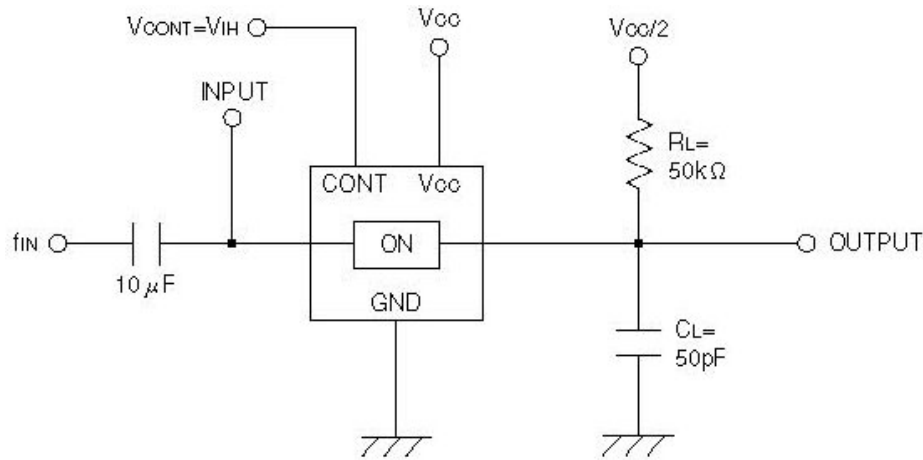

* Input by sine wave

■ -3dB Band Width

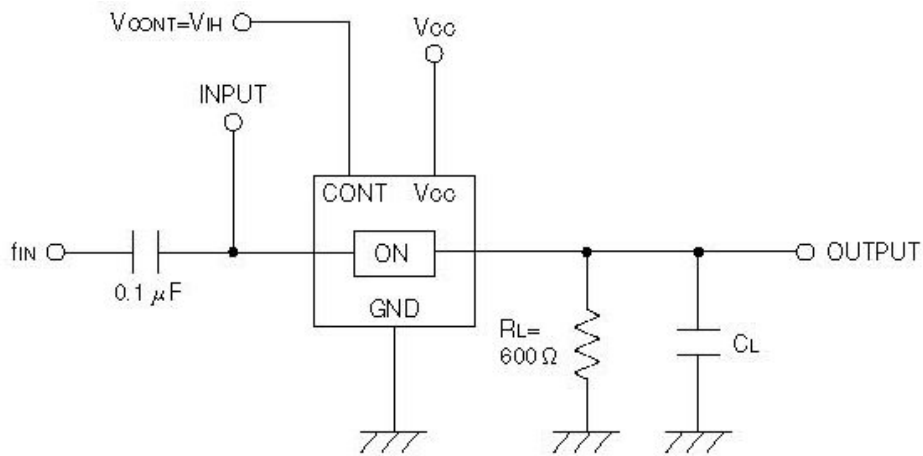

* Input by sine wave ($V_{IN}=0\text{dBm}$, $f=1\text{MHz}$)

■ Feed Through Test Circuit

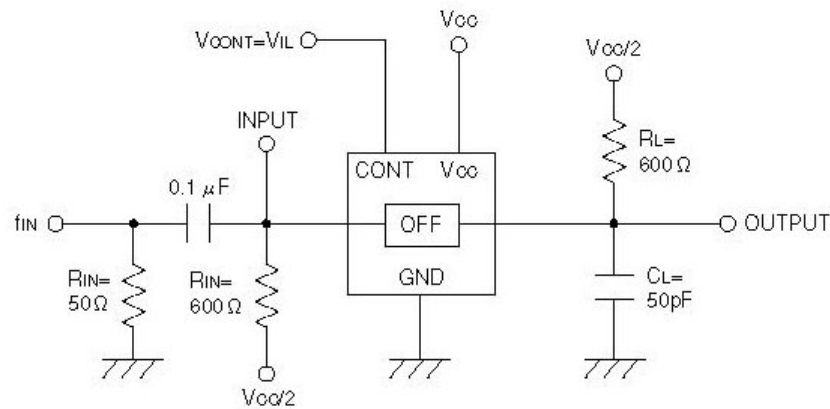

* Input by sine wave ($V_{IN}=0dBm$, $f=1MHz$)

■ Cross Talk (Control Input → Switch Output)

■ Typical Application Circuit

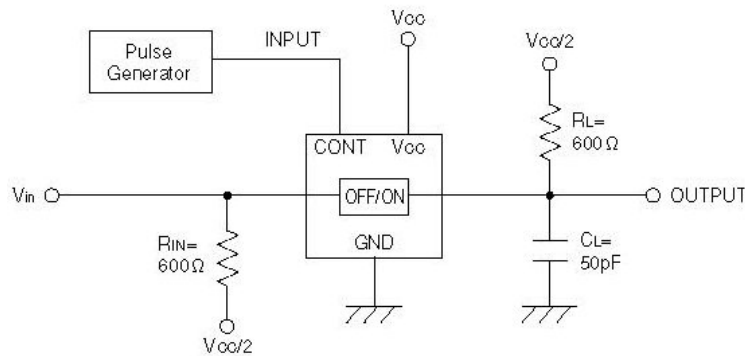

■ Waveforms

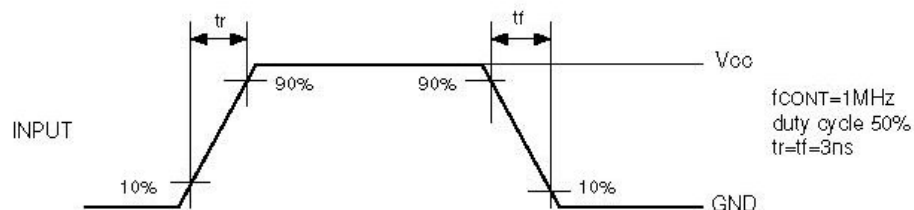

■ Cross Talk (Between Switches)

■ Typical Application Circuit

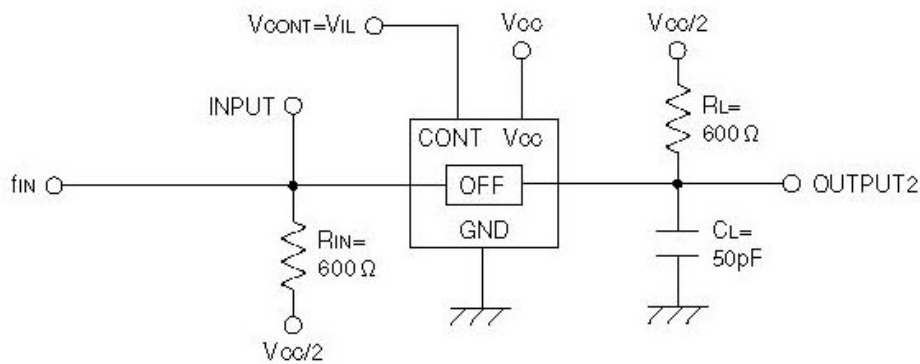
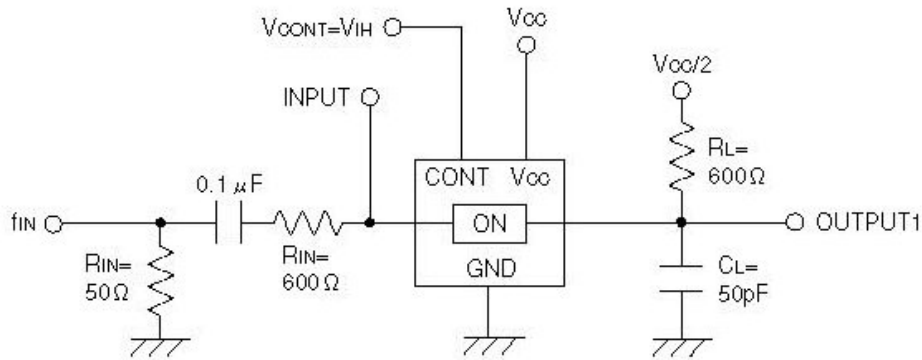

■ Waveforms

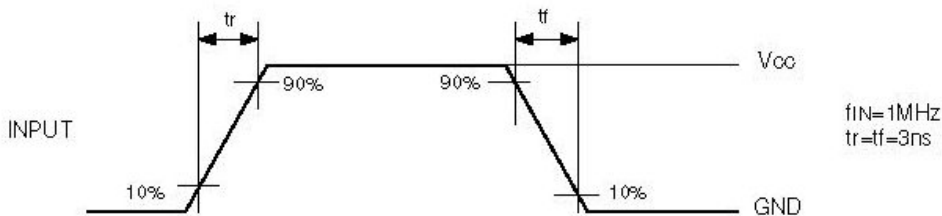

DISCLAIMER:

The information presented in this document does not form part of any quotation or contract, is believed to be accurate and reliable and may be changed without notice. No liability will be accepted by the publisher for any consequence of its use.