

- ◆ **COMS 2-Input NAND Gate**
- ◆ **Operating Voltage Range : 2V ~ 5.5V**
- ◆ **High Speed Operations : tpd = 2ns TYP**
- ◆ **Low Power Consumption : 1μA (max)**
- ◆ **Low ON Resistance : Ron=22Ω TYP**

■ Applications

- Palmtops
- Digital Equipment

■ General Description

The ML74UL00MRG is a 2-input CMOS NAND gate, manufactured using silicon gate CMOS fabrication.

CMOS low power circuit operation makes high speed LS-TTL operations achievable.

With a wave forming buffer connected internally, stabilized output can be achieved as the circuit offers high noise immunity.

AS the ML74UL00MRG is integrated into mini molded, SOT-23-5 package, high density mounting possible.

■ Features

High Speed Operation : tpd = 2.6ns TYP

Operating Voltage Range: 2V ~ 5.5V

Low Power Consumption: 1μA (max)

Ultra Small Package : SOT-23-5

■ Pin Configuration

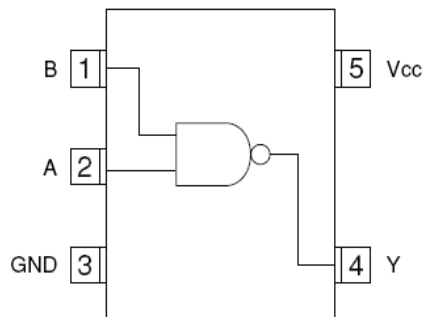

SOT-23-5 (TOP VIEW)

■ Function

INPUT		OUTPUT
A	B	Y
L	L	H
L	H	H
H	L	H
H	H	L

H=High level, L=Low level

■ Absolute Maximum Ratings

Ta=-40°C~85°C

PARAMETER	SYMBOL	RATINGS	UNITS
Power Supply Voltage	Vcc	-0.5 ~ +6.0	V
Input voltage	VIN	-0.5 ~ +6.0	V
Output Voltage	VOUT	-0.5 ~ Vcc +0.5	V
Input Diode Current	I _{IK}	±20	mA
Output Diode current	I _{OK}	±20	mA
Output Current	I _O UT	±25	mA
Vcc, GND Current	I _{CC} , I _{GND}	±50	mA
Continuous Total Power Dissipation (Ta=55°C)	P _d	150	mW
Storage Temperature	T _{stg}	-65 ~ +150	°C

Note: Voltage is all Ground standardized.

■ Recommended Operating Conditions

PARAMETER	SYMBOL	V _{cc} (V)	CONDITIONS	UNITS
Supply Voltage	V _{cc}	-	2 ~ 5.5	V
Input Voltage	V _{IN}	-	0 ~ 5.5	V
Output Voltage	V _{OUT}	-	0 ~ V _{cc}	V
Operating Temperature	T _{opr}	-	-40 ~ +85	°C
Output Current	I _{OH}	3.0	-4	mA
		4.5	-8	
	I _{OL}	3.0	4	
		4.5	8	
Input Rise and Fall Time	tr, tf	3.3	0 ~ 100	Ns/V
		5.0	0 ~ 20	

■ DC Electrical Characteristics

PARAMETER	SYMBOL	V _{cc} (V)	CONDITIONS	Ta=25°C			Ta=-40~85°C		UNITS		
				MIN	TYP	MAX	MIN	MAX			
Input Voltage	V _{IH}	2.0		1.5	-	-	1.5	-	V		
		3.0		2.1	-	-	2.1	-			
		5.5		3.85	-	-	3.85	-			
	V _{IL}	2.0		-	-	0.5	-	0.5	V		
		3.0		-	-	0.9	-	0.9			
		5.5		-	-	1.65	-	1.65			
Output Voltage	V _{OH}	2.0	V _{IN} =V _{IH} or V _{IL}	I _{OH} =-50μA	1.9	2.0	-	1.9	-	V	
		3.0			2.9	3.0	-	2.9	-		
		4.5			4.4	4.5	-	4.4	-		
		3.0		I _{OH} =-4mA	2.58	-	-	2.48	-		
		4.5		I _{OH} =-8mA	3.94	-	-	2.80	-		
	V _{OL}	V _{IN} =V _{IH}	2.0	I _{OL} =50μA	-	-	0.1	-	0.1	V	
					3.0	-	-	0.1	-		0.1
					4.5	-	-	0.1	-		0.1
			3.0		I _{OL} =4mA	-	-	0.36	-		0.44
			4.5		I _{OL} =8mA	-	-	0.36	-		0.44
Input Current	I _{IN}	5.5	V _{IN} =V _{cc} or GND	-0.1	-	0.1	-1.0	1.0	μA		
Quiescent Supply Current	I _{cc}	5.5	V _{IN} =V _{cc} or GND, I _{OUT} =0μA	-	-	1.0	-	10.0	μA		

■ Switching Electrical Characteristics

PARAMETER	SYMBOL	C _L	V _{cc} (V)	CONDITIONS	Ta=25°C			Ta=-40~85°C		UNITS
					MIN	TYP	MAX	MIN	MAX	
Propagation Delay Time	t _{PLH}	15pF	3.3		-	3.7	7.9	1	9.5	ns
			5.0		-	2.7	5.5	1	6.5	
		50pF	3.3		-	5.4	11.4	1	13	ns
			5.0		-	3.6	7.5	1	8.5	
	t _{PHL}	15pF	3.3		-	3.3	7.9	1	9.5	ns
			5.0		-	2.5	5.5	1	6.5	
		50pF	3.3		-	4.6	11.4	1	13	ns
			5.0		-	3.5	7.5	1	8.5	
Input Capacitance	C _{IN}	-	5.0	V _{IN} =V _{cc} or GND	-	2	10	-	10	pF
Power Dissipation Capacitance	C _{pd}	No Load, f=1MHz		-	9.3	-	-	-	-	pF

Tr=tf=3ns

■ Typical Application Circuit

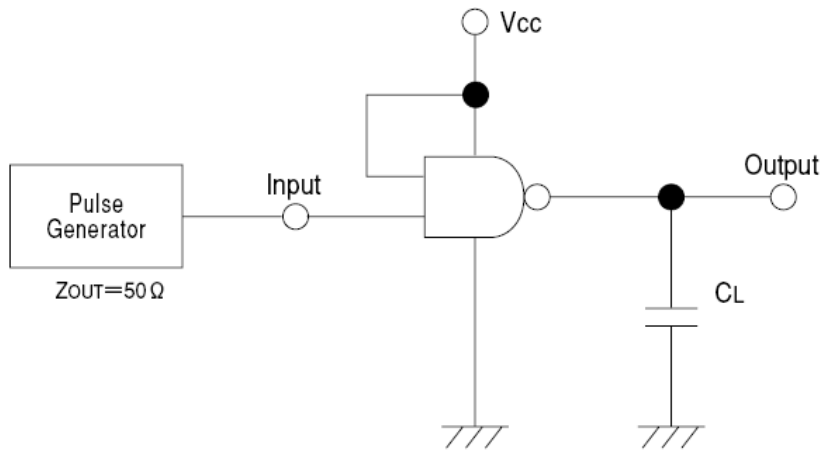

Note: Open output when measuring supply current

■ Waveforms

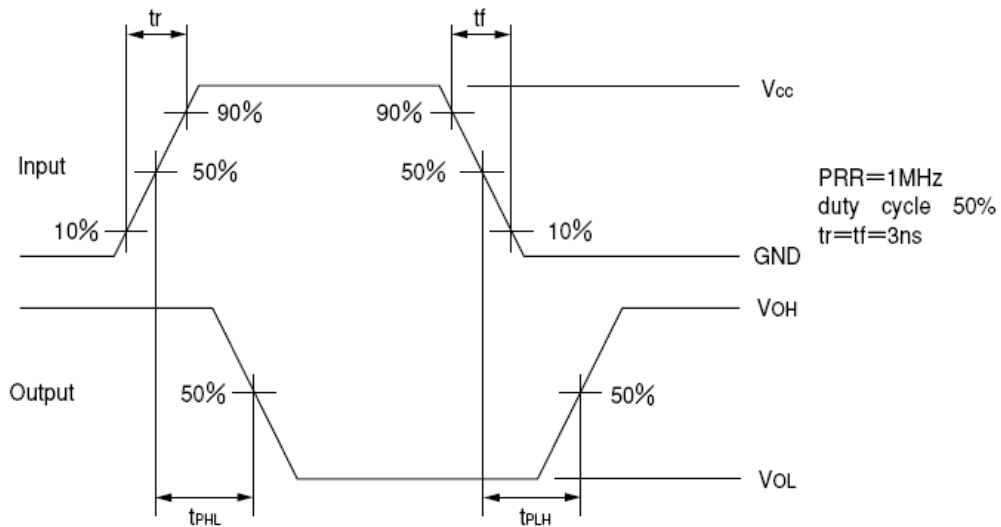

DISCLAIMER:

The information presented in this document does not form part of any quotation or contract, is believed to be accurate and reliable and may be changed without notice. No liability will be accepted by the publisher for any consequence of its use.