

ML61 Series Positive Voltage Detector

❖ Application

- ◆ Memory Battery Back-up Circuits
- ◆ Microprocessor Reset Circuitry
- ◆ Power Failure Detection
- ◆ Power-on Reset Circuit
- ◆ System Battery Life and Charge Voltage Monitor

❖ Features

- CMOS Low Power Consumption : Typical 1.0uA at $V_{in}=2.0V$
- Selectable Detect Voltage : 1.1V to 7.0V in 0.1V increments
- Highly Accurate : Detect Voltage 1.1V to 1.9V $\pm 3\%$
Detect Voltage 2.0V to 7.0V $\pm 2\%$
- Operating Voltage : 0.8V to 10.0V
- Package Available : SOT23 (150mW), SOT89 (500mW) & TO92 (300mW)

❖ General Description

The ML61 is a group of high-precision and low-power voltage detectors.

The ML61 consists of a highly-accurate and low-power reference voltage source, a comparator, a hysteresis circuit, and an output driver. Detect voltage is very accurate and stable with N-channel open drain and CMOS, are available.

❖ Block Diagram

(1) CMOS Output

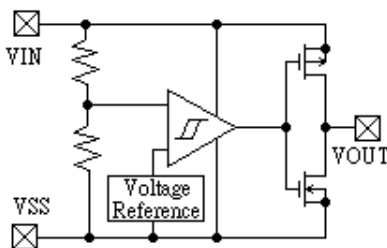

(2) N-Channel Open Drain Output

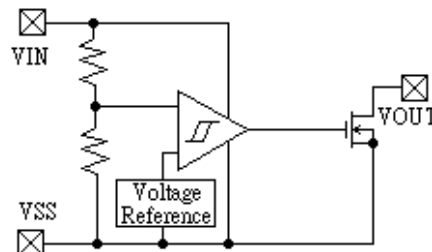

❖ Absolute Maximum Ratings

Parameter	Symbol	Ratings	Units
Input Voltage	V_{IN}	10	V
Output Current	I_{OUT}	50	mA
Output Voltage	V_{OUT}	$V_{SS}-0.3 \sim V_{IN}+0.3$	V
Continuous Total Power Dissipation	P_d	SOT-23	150
		SOT-89	500
		TO-92	300
Operating Ambient Temperature	T_{opr}	-40 ~ +70	$^{\circ}C$
Storage Temperature	T_{stg}	-40 ~ +70	$^{\circ}C$

❖ Electrical Characteristics

<i>Parameter</i>	<i>Symbol</i>	<i>Conditions</i>	<i>Min</i>	<i>Typ</i>	<i>Max</i>	<i>Units</i>
<i>Detect Voltage</i>	V_{DF}	$V_{DF} = 1.1V \text{ to } 1.9V$	X0.97	V_{DF}	X1.03	V
		$V_{DF} = 2.0V \text{ to } 7.0V$	X0.98	V_{DF}	X1.02	V
<i>Hysteresis Range</i>	V_{HYS}	$V_{DF} = 1.1V \text{ to } 2.9V$	X0.04	$V_{DF} \times 0.05$	X0.06	V
		$V_{DF} = 3.0V \text{ to } 7.0V$	X0.015	$V_{DF} \times 0.025$	X0.035	V
<i>Supply Current</i>	I_{SS}	$V_{IN} = 1.0V$		0.8	2.0	uA
		$V_{IN} = 2.0V$		1.0	2.5	
		$V_{IN} = 3.0V$		1.3	3.0	
		$V_{IN} = 4.0V$		1.6	3.5	
		$V_{IN} = 5.0V$		2.0	4.0	
<i>Operating Voltage</i>	V_{IN}	$V_{DF} = 1.1 \sim 7.0V$	0.8		10.0	V
<i>Output Current</i>	I_{OUT}	<i>Nch</i> $V_{DS} = 0.5V$ $V_{IN} = 1.0V$ $V_{IN} = 2.0V$ $V_{IN} = 3.0V$ $V_{IN} = 4.0V$ $V_{IN} = 5.0V$		1.0		mA
				3.0		
				5.0		
				11.0		
				13.0		
	<i>Pch</i> $V_{DS} = 2.1V$ $V_{IN} = 8.0V$ (CMOS Output)		-10.0			
<i>Transient Delay Time</i> ($V_{DR} \rightarrow V_{OUT}$ Inversion)	t_{DLY}	<i>While V_{IN} changes from 0.6V to 10V</i>			0.2	ms

❖ Electrical Characteristics By Detector Threshold

Part Number	Standard Detector Accuracy	Detector Threshold			Hysteresis Range		Supply Current					
		V _{DF} (V)			V _{HYS} (V)		I _{SS} (uA)					
		MIN.	TYP.	MAX.	MIN.	MAX.	Condition	TYP.	MAX.			
ML61X113XX	3%	1.067	1.100	1.133	V _{DF} x 0.04	V _{DF} x 0.06	V _{IN} = 1.0V	0.8	2.0			
ML61X123XX												
ML61X133XX												
ML61X143XX												
ML61X153XX												
ML61X163XX												
ML61X173XX												
ML61X183XX												
ML61X193XX												
ML61X202XX												
ML61X212XX												
ML61X222XX												
ML61X232XX												
ML61X242XX												
ML61X252XX												
ML61X262XX												
ML61X272XX												
ML61X282XX												
ML61X292XX												
ML61X302XX	2%	2.940	3.000	3.060	V _{DF} x 0.015	V _{DF} x 0.035	V _{IN} = 3.0V	1.3	3.0			
ML61X312XX												
ML61X322XX												
ML61X332XX												
ML61X342XX												
ML61X352XX												
ML61X362XX												
ML61X372XX												
ML61X382XX												
ML61X392XX												
ML61X402XX												
ML61X412XX												
ML61X422XX												
ML61X432XX												
ML61X442XX												
ML61X452XX												
ML61X462XX												
ML61X472XX												
ML61X482XX												
ML61X492XX												
ML61X502XX												
ML61X512XX												
ML61X522XX												
ML61X532XX												
ML61X542XX												
ML61X552XX												
ML61X562XX												
ML61X572XX												
ML61X582XX												
ML61X592XX												
ML61X602XX												
ML61X702XX												
			6.860	7.000			7.210			V _{IN} = 6.0V	2.4	4.5

Part Number	Operating Voltage		Pch Output Current		Nch Output Current		Transient Delay Time
	V_{IN} (V)		Pch I_{OUT} (mA)		Nch I_{OUT} (mA)		t_{DLY} (ms)
	MIN.	MAX.	Condition	TYP.	Condition	TYP.	MAX.
ML61X113XX	0.8V	10V	$V_{DS} = 2.1V$ $V_{IN} = 8.0V$	-10.0	$V_{DS} = 0.5V$ $V_{IN} = 1.0V$	1.0	0.2
ML61X123XX							
ML61X133XX							
ML61X143XX							
ML61X153XX							
ML61X163XX							
ML61X173XX							
ML61X183XX							
ML61X193XX							
ML61X202XX							
ML61X212XX							
ML61X222XX							
ML61X232XX					$V_{DS} = 0.5V$ $V_{IN} = 2.0V$	3.0	
ML61X242XX							
ML61X252XX							
ML61X262XX							
ML61X272XX							
ML61X282XX							
ML61X292XX							
ML61X302XX							
ML61X312XX							
ML61X322XX							
ML61X332XX							
ML61X342XX							
ML61X352XX							
ML61X362XX							
ML61X372XX							
ML61X382XX							
ML61X392XX							
ML61X402XX							
ML61X412XX							
ML61X422XX							
ML61X432XX							
ML61X442XX							
ML61X452XX							
ML61X462XX					$V_{DS} = 0.5V$ $V_{IN} = 4.0V$	11.0	
ML61X472XX							
ML61X482XX							
ML61X492XX							
ML61X502XX							
ML61X512XX							
ML61X522XX							
ML61X532XX							
ML61X542XX							
ML61X552XX							
ML61X562XX							
ML61X572XX							
ML61X582XX	$V_{DS} = 0.5V$ $V_{IN} = 5.0V$	13.0					
ML61X592XX							
ML61X602XX							
ML61X702XX							

❖ *Pin Configuration*

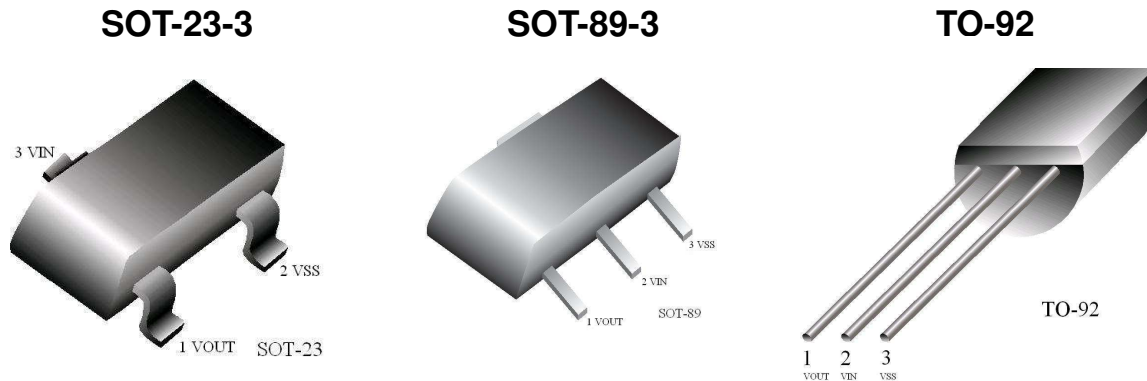

Package Pin Number			Pin Name	Function
SOT-23-3	SOT-89-3	TO-92		
1	1	1	VOUT	Supply Voltage Output
3	2	2	VIN	Supply Voltage Input
2	3	3	VSS	Ground

❖ *Test Circuits*

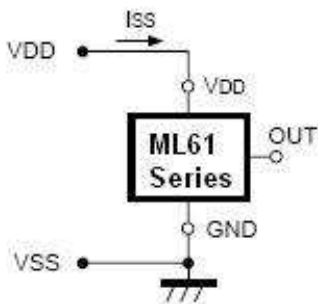

Supply Current Test Circuit

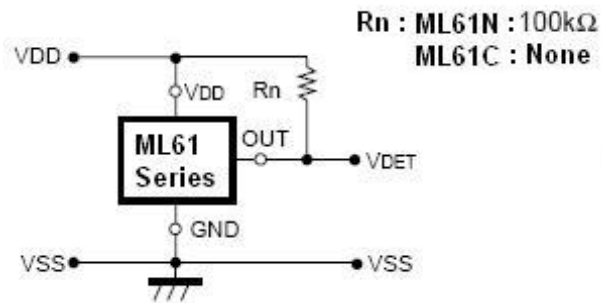

Detector Threshold Test Circuit

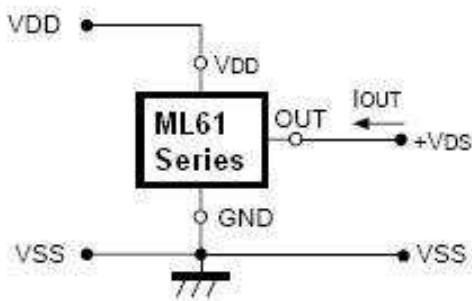

Nch Driver Output Current Test Circuit

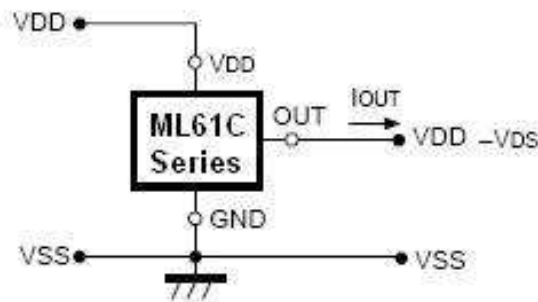

Pch Driver Output Current Test Circuit

❖ *Functional Description (Refers to CMOS Output)*

1. Firstly, when a voltage, higher than the Release Voltage (V_{DR}), is applied to the Voltage Input pin (V_{IN}), that voltage will gradually fall. When a voltage higher than the Detect Voltage (V_{DF}) is applied to the Input Voltage pin (V_{IN}), output at V_{OUT} will be equal to the input at the V_{IN} pin. High impedance exists on the Output pin (V_{OUT}) with the N-channel open drain configuration. If the pin is pulled-up, V_{OUT} will be identical to the pull-up voltage.
2. When the input Voltage (V_{IN}) falls below the Detect Voltage (V_{DF}) level, the Output Voltage (V_{OUT}) is equal to the Ground Voltage (V_{SS}) level (detect state). Also applicable to N-channel open drain configuration.
3. When the Input Voltage (V_{IN}) falls below the Minimum Operating Voltage (V_{MIN}) level, output becomes unstable. In the case of N-channel open drain configuration, as the output pin is generally pulled-up, the output will be equal to the pull-up voltage.
4. When the Input Voltage (V_{IN}) rises, output become stable once the voltage has exceeded V_{MIN} . The Output Voltage (V_{OUT}) will remain equal to the Ground Voltage (V_{SS}) level until the Input Voltage (V_{IN}) reaches the Detect Release Voltage (V_{DR}) level.
5. When the Input Voltage (V_{IN}) rises above the Detect Release Voltage (V_{DR}) level, output at the Output pin (V_{OUT}) is equal to V_{IN} . (High impedance exists with the N-channel open drain output configuration and V_{OUT} follows the pull-up voltage.)

Notes :

1. The difference between V_{DR} and V_{DF} represents the Hysteresis Range.
2. The Propagation Delay Time (t_{DLY}) represents the time it takes for the Input Voltage (V_{IN}) to appear at the Output pin (V_{OUT}), once the said voltage has exceeded the Release Voltage (V_{DR}) level.

❖ *Timing Diagram*

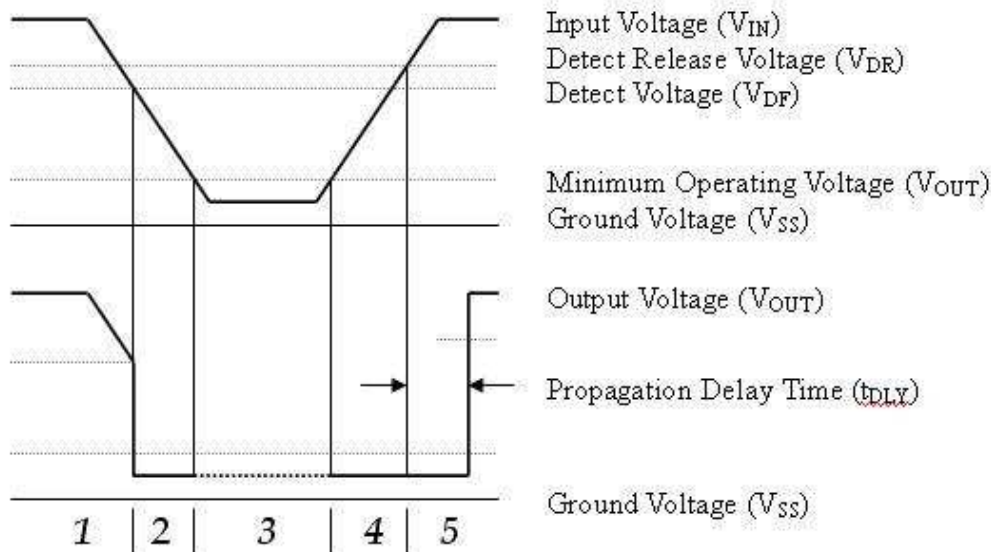

❖ *Typical Performance Characteristics*

1) Supply Current vs. Input Voltage

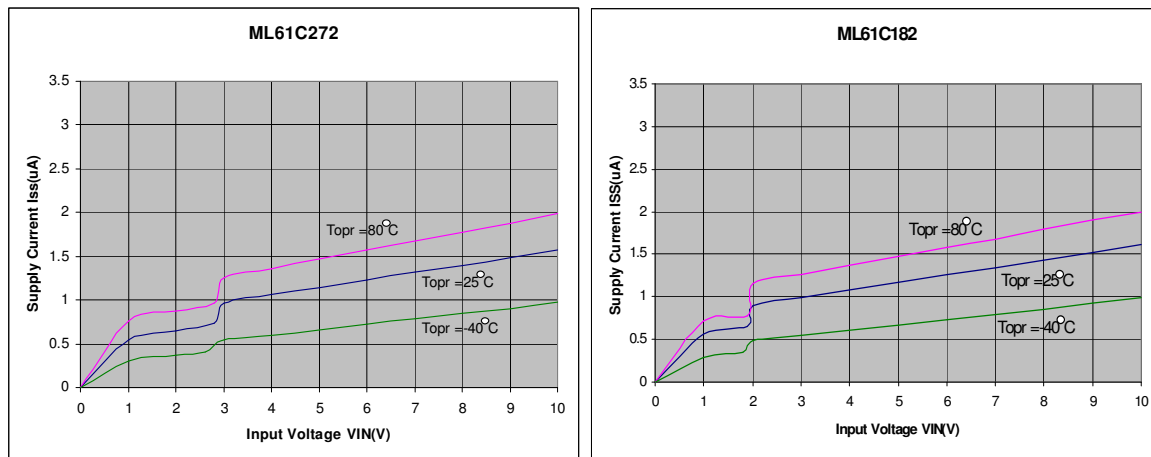

2) Detect, Release Voltage vs. Ambient Temperature

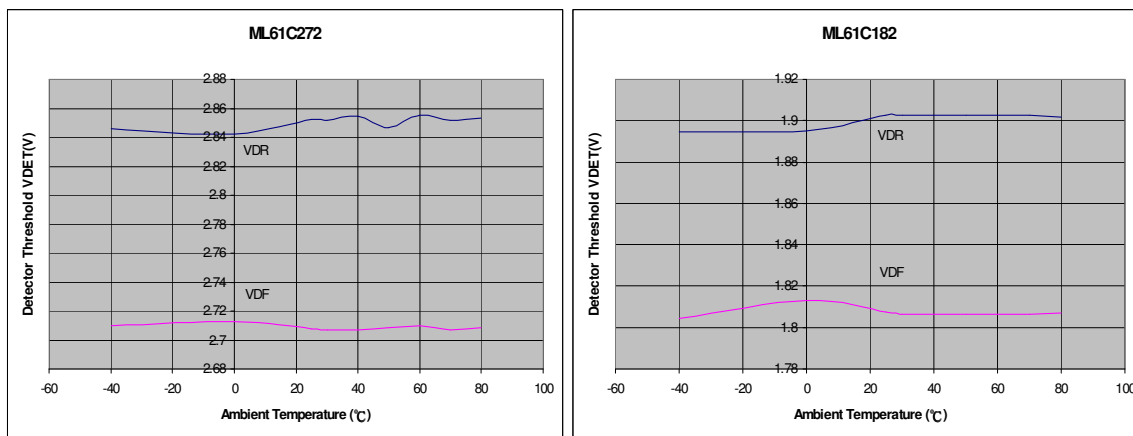

3) Output Voltage vs. Input Voltage

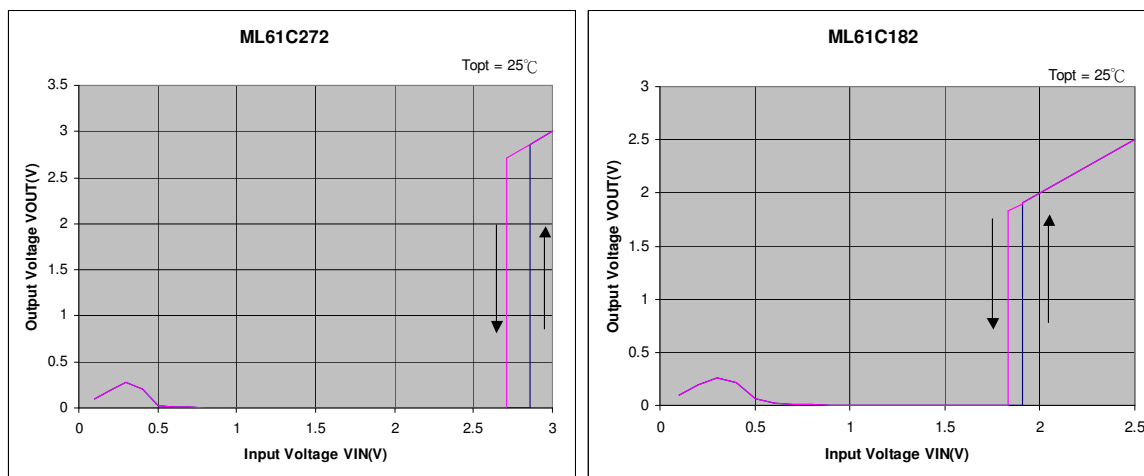

4) N-ch Driver Output Current vs. V_{DS}

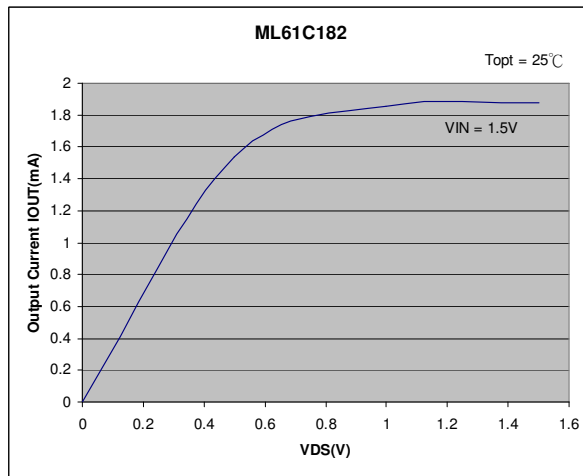
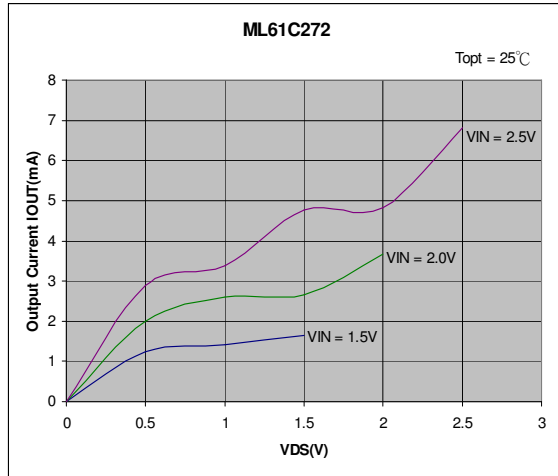

5) N-ch Driver Output Current vs. Input Voltage

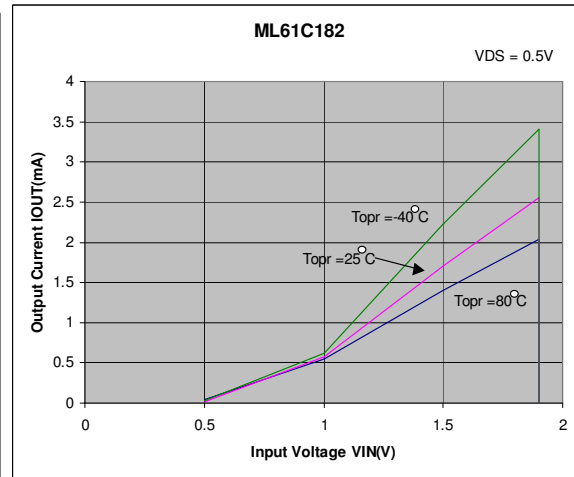
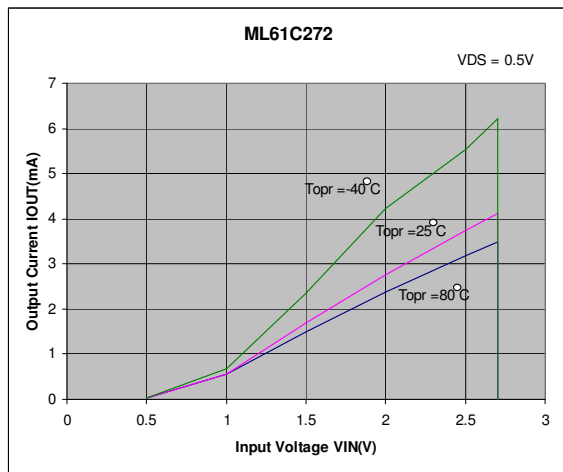

6) P-ch Driver Output Current vs. Input Voltage

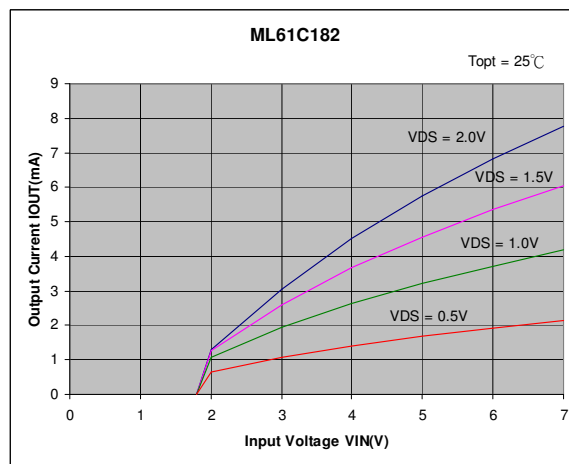
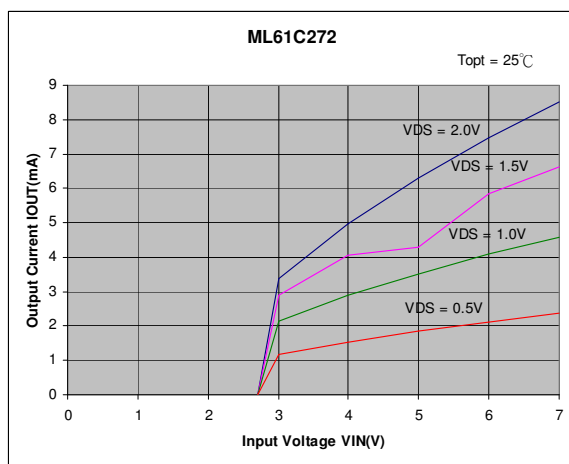

❖ Ordering Information

Designator	Description
a	Output Configuration C = CMOS Output N = N-Channel Output
b	Detect Voltage eg. 30=3.0V 50=5.0V
c	Detect Voltage Accuracy 2 = ±2.0% 3 = ±3.0%
d	Package Type M = SOT-23-3 P = SOT-89 T = TO-92
e	Device Orientation R = Embossed Tape (Orientation of Device : Right) L = Embossed Tape (Orientation of Device : Left) B = Bag (TO-92) H = Paper Tape (TO-92)
f	G = ROHS Part GG = Green Part

ML61 x x x x x x x
 † † † † † † †
 a b c d e f

❖ Marking

SOT-23-3 :

Designator	Description
1	Type C = Voltage Detector (CMOS Output) N = Voltage Detector (N-channel Output)
2,3	Output Voltage eg. 30 = 3.0V
4	Internal Code

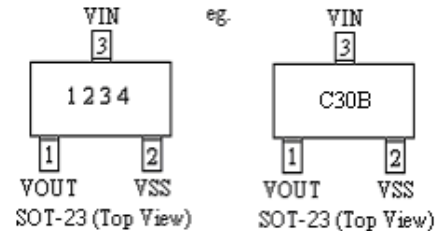

SOT-89-3 :

Designator	Description
1	Type C = Voltage Detector (CMOS Output) N = Voltage Detector (N-channel Output)
2,3	Output Voltage eg. 30 = 3.0V
4	Internal Code

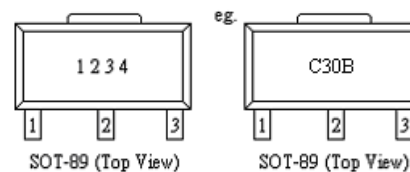

TO-92 :

Designator	Description
1	Type C = Voltage Detector (CMOS Output) N = Voltage Detector (N-channel Output)
2,3	Output Voltage eg. 30 = 3.0V
4	Internal code
5, 6	Year Code eg. 05 = Year 2005
7, 8	Week Code eg. 30 = Week 30

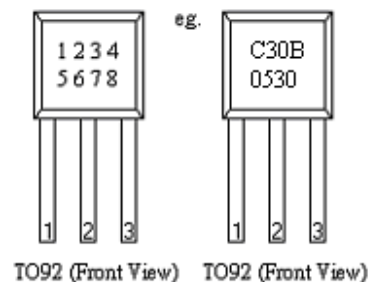

❖ *Packaging Information*

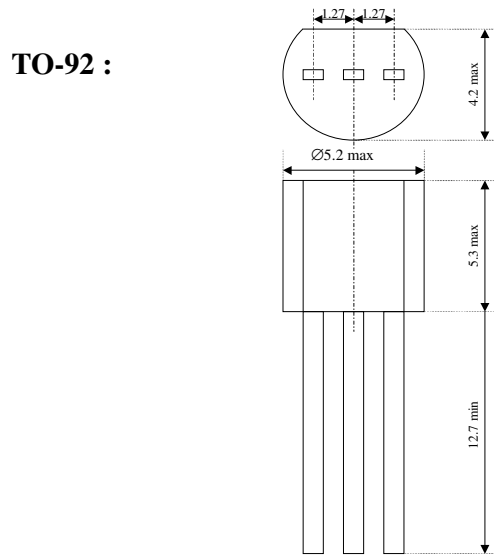
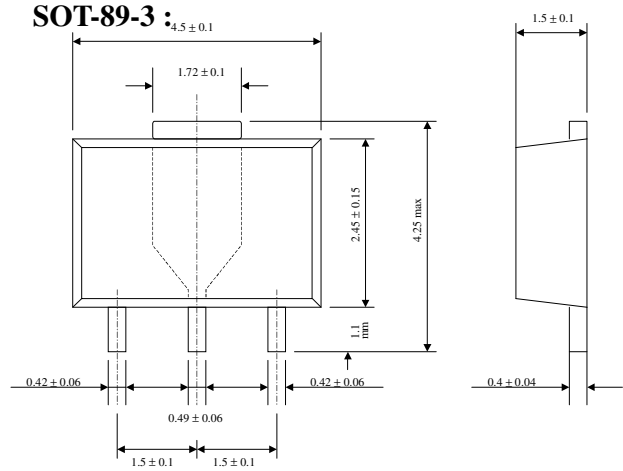
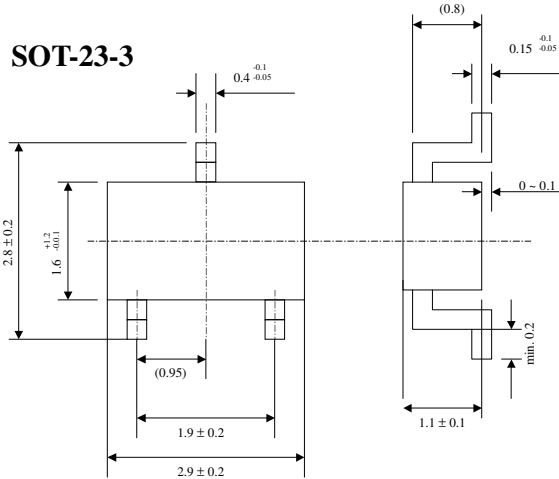

Units : mm

❖ *Recommended Pattern Layout*

SOT-23-3 :

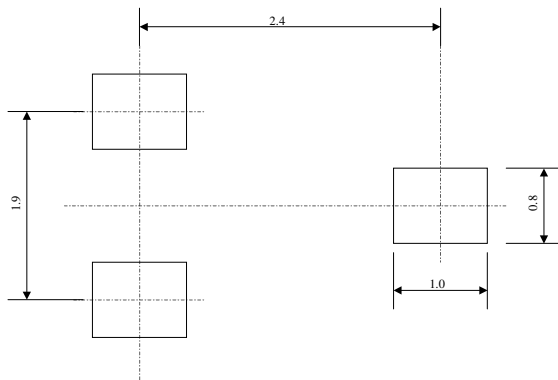

SOT-89-3 :

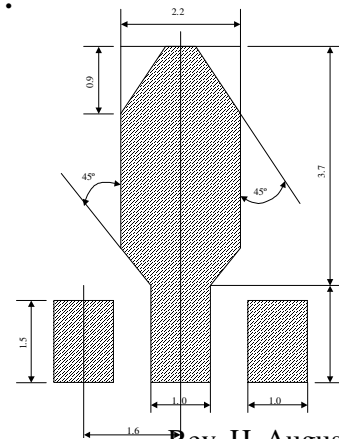

❖ *Tape and Reel Information*

SOT-23 :

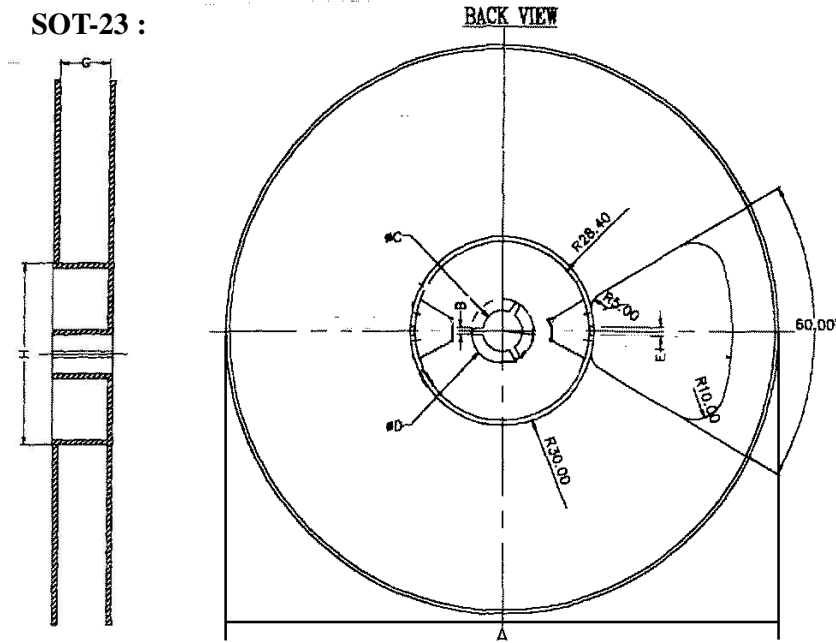

	SIZE (mm)
A	∅ 178 ± 0.8
B	2 ± 0.2
C	∅ 13 ± 0.2
D	∅ 21 ± 0.8
G	8 ± 0.5
H	∅ 60

3,000 pcs / reel

SOT-23 Taping Specifications :

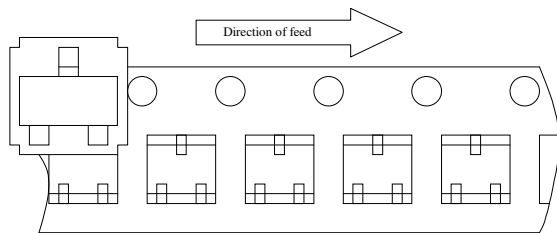
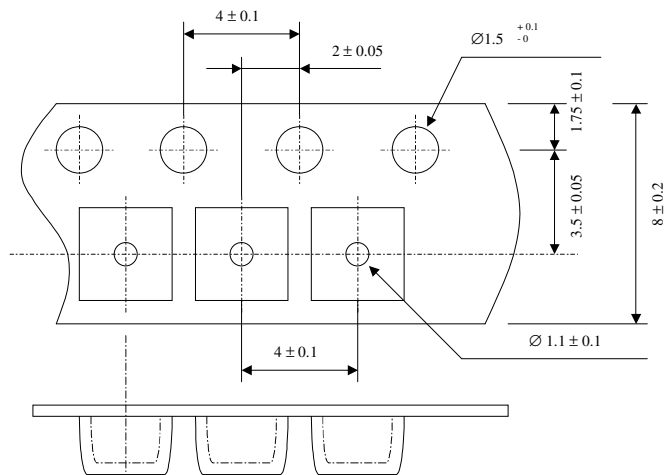

"R" type [Orientation of Device: Right]
Standard Type

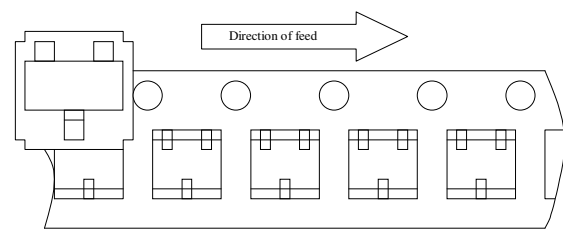

"L" type [Orientation of Device: Left]
Reverse Type

SOT-89 :

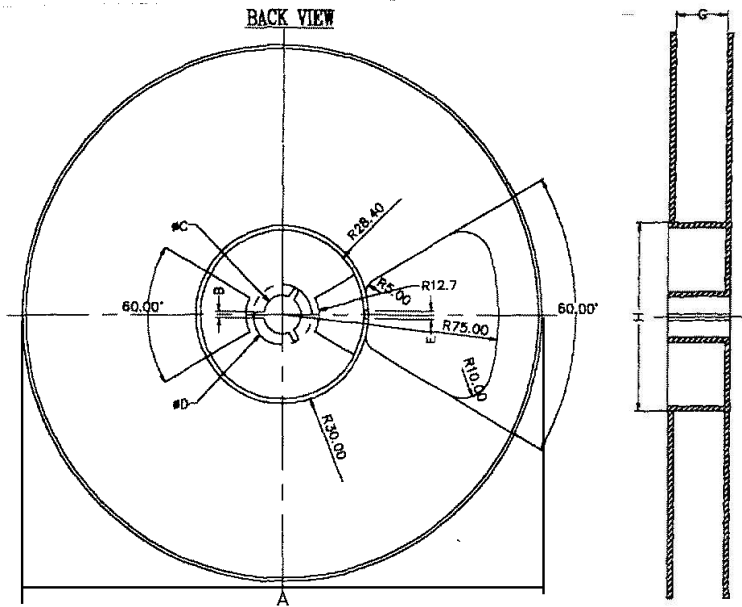

	SIZE (mm)
A	$\varnothing 178 \pm 0.8$
B	2 ± 0.2
C	$\varnothing 13 \pm 0.2$
D	$\varnothing 21 \pm 0.8$
G	12 ± 0.5
H	$\varnothing 60$

1,000 pcs / reel

SOT-89 Taping Specifications :

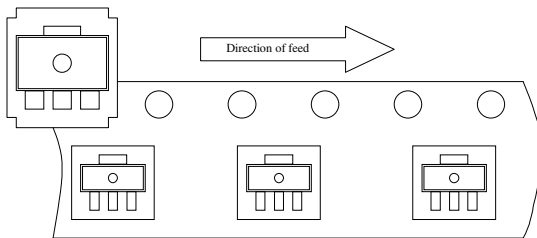
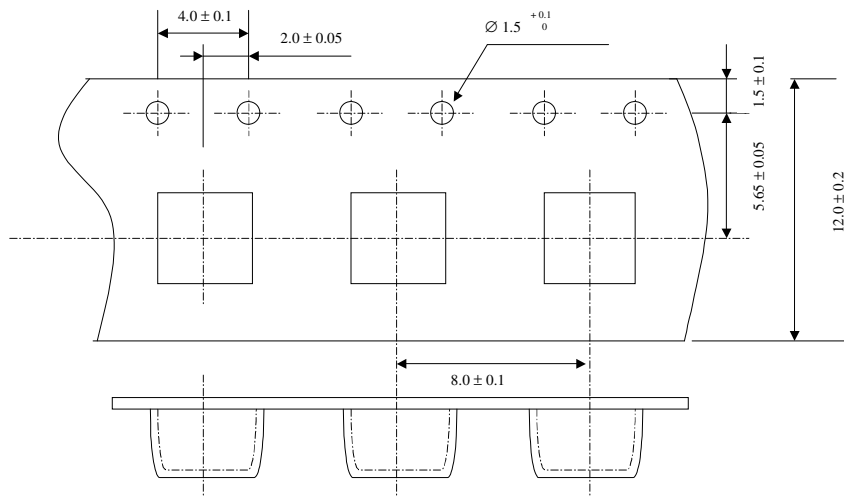

"R" type [Orientation of Device: Right]
Standard Type

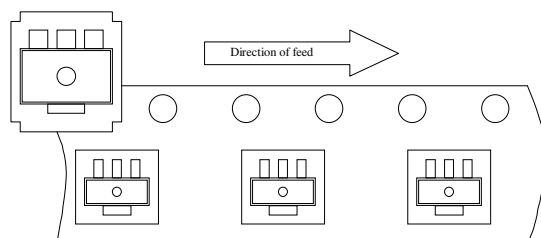

"L" type [Orientation of Device: Left]
Reverse Type

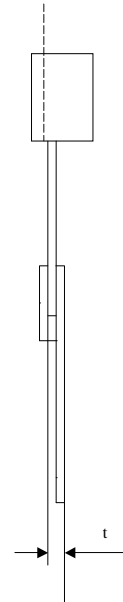
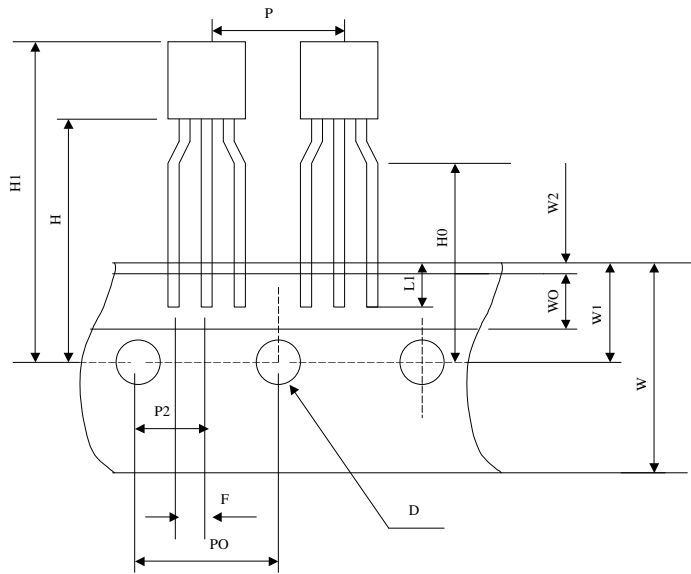
TO-92 Taping Specifications :

	SIZE (mm)
P	12.7 ± 1.0
PO	12.7 ± 0.3
P2	6.35 ± 0.4
F	2.5 +0.45/-0.15
W	18.0 ± 1.0
W0	6.0 ± 0.3
W1	9.0 ± 0.5
W2	0.5 MAX
H	19.0 ± 0.5
H0	16.0 ± 0.5
H1	32.25 MAX
D	∅ 4.0 ± 0.2
t	0.6 ± 0.2
L1	3.5 MIN

2,000 pcs / box

MiniLogic reserves the rights to change the information and specifications without prior notice. The information presented in this document does not form part of any quotation or contract, is believed to be accurate and reliable and may be changed without notice. No liability will be accepted by the publisher for any consequence of its use.