



ML3406

Synchronous Step-Down DC-DC Controller

Vout=1.5V, 1.8V Iout=600mA f=1.5MHz

■ Description

The ML3406 is a high efficiency monolithic synchronous step-down regulator using a constant frequency, current mode architecture. The 2.5V to 5.5V input voltage range makes the ML3406 ideally suited for single LI-Ion battery-powered applications. 100% duty cycle provides low dropout operation extending battery life in portable systems. Automatic Burst Mode operation increases efficiency at light loads, further extending battery life. Switching frequency is internally set at 1.5MHz, allowing the use of small surface mount inductors and capacitors. The internal synchronous switch increases efficiency and eliminates the need for an external Schottky diode. Low output voltages are easily supported with the 0.6V feed-back reference voltage. The ML3406 is available in a low profile SOT-23-5L package.

■ Ordering Information

Item	Package	Shipping
ML3406NFBMRG	SOT-23-5L	3000/Reel&Tape

■ Typical Information

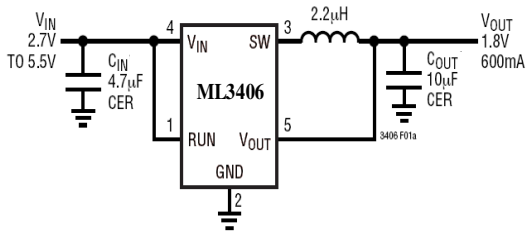

Figure 1

■ Features

- 2.5V to 5.5V Input Voltage Range
- 600mA Output Current
- 1.5MHz Constant Frequency Operation
- Low Quiescent Current: Only 20µA During Operation
- High Efficiency: Up to 96%
- Low Dropout Operation: 100% Duty Cycle
- No Schottky Diode Required
- 0.6 V Reference Allows Low Output Voltages
- Shutdown Mode Draws ≤ 1µA Supply Current
- Current Mode Operation for Excellent Line and Load Transient Response
- Over temperature Protected
- Mini Package SOT-23-5L

■ Application

- Cellular Telephones
- Personal Information Appliances
- Wireless and DSL Modems
- Digital Still Cameras
- MP3 Players
- Portable Instruments

■ Efficiency – Load current

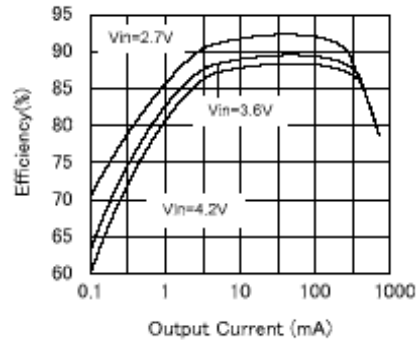
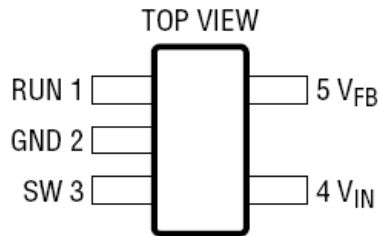

Figure 2



■ Pin Configuration



■ Marking Rule

	Description	Symbol
① ②	ML3406	A1
③ ④	Date Code	XY

Note : XY is date code of the chip

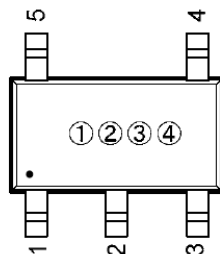

■ Pin Functions

Run (Pin1):

Run control Input. Forcing this pin above 1.5V enables the part. Forcing this pin below 0.3V shuts down the device. In shutdown, all functions are disabled drawing <1μA supply current. Do not leave RUN floating.

GND (Pin 2):

Ground Pin.

SW (Pin 3):

Switch Node Connection to Inductor. This pin connects to the drains of the internal main and synchronous power MOSFET switches.

Vin (Pin 4):

Main Supply Pin. Must be closely decoupled to GND, Pin 2, with a 2.2μF or greater ceramic capacitor.

V_{FB} (Pin 5) (ML3406-FB):

Feedback Pin. Receives the feedback voltage from an external resistive divider across the output.



■ Absolute Maximum Ratings ($T_a=25^\circ\text{C}$, $V_{in}=3.6\text{V}$ unless otherwise specified)

Parameter	Symbol	Maximum Ratings	Unit
Input Supply Voltage	V_{in}	-0.3V to 6V	V
Run, V_{FB} Voltages	V_{FB} , V_{RUN}	-0.3V to V_{IN}	V
SW Voltage	V_{SW}	-0.3V to ($V_{IN} + 0.3\text{V}$)	V
P-Channel Switch Source Current (DC)	I_{SW-P}	800mA	mA
N-Channel Switch Sink Current (DC)	I_{SW-N}	800mA	mA
Peak SW Sink and Source Current	I_{SWmax}	1.3A	A
Operating Temperature Range	T_a	0°C to 70°C	$^\circ\text{C}$
Junction Temperature (Note 3)	T_j	125°C	$^\circ\text{C}$
Storage Temperature Range	T_{stg}	-65°C to 150°C	$^\circ\text{C}$
Lead Temperature (Soldering, 10 sec)	T_L	300°C	$^\circ\text{C}$

■ Electrical Characteristics ($T_a=25^\circ\text{C}$, $V_{in}=3.6\text{V}$ unless otherwise specified)

Parameter	Symbol	Condition		Min	Typ.	Max	Unit	
Feedback Current	I_{VFB}		*			± 30	nA	
Regulated Feedback Voltage	V_{FB}	$T_a=25^\circ\text{C}$		588.0	600	612.0	mV	
		0°C $T_a \leq 85^\circ\text{C}$		586.5	600	613.5	mV	
		$-40^\circ\text{C} \leq T_a \leq 85^\circ\text{C}$	*	585.0	600	615.0	mV	
Reference Voltage Line Regulation	ΔV_{FB}	$V_{IN}=2.5\text{V}$ to 5.5V (Note4)	*		0.04	0.4	%/V	
Output voltage Line Regulation	ΔV_{OUT}	$V_{IN}=2.5\text{V}$ to 5.5V	*		0.04	0.4	%/V	
Peak Inductor Current	I_{PK}	$V_{IN}=3\text{V}$, $V_{FB}=0.5\text{V}$ or $V_{OUT}=90\%$, Duty Cycle < 35%		0.75	1	1.25	A	
Output Voltage Load Regulation	$V_{LOADREG}$				0.5		%	
Input Voltage Range	V_{IN}		*	2.5		5.5	V	
Input DC Bias Current	Active Mode Sleep Mode Shutdown	I_S		$V_{FB}=0.5$ or $V_{OUT}=90\%$, $I_{LOAD}=0\text{A}$		300	400	μA
				$V_{FB}=0.62\text{V}$ or $V_{OUT}=103\%$, $I_{LOAD}=0\text{A}$		20	35	μA
				$V_{RUN}=0\text{V}$, $V_{IN}=4.2\text{V}$		0.1	1	μA
Oscillator Frequency	f_{OSC}		*	$V_{FB}=0.6\text{V}$ or $V_{OUT}=100\%$		1.2	1.5	MHz
				$V_{FB}=0\text{V}$ or $V_{OUT}=0\text{V}$			210	kHz
$R_{DS(ON)}$ of P-Channel FET	R_{PFET}	$I_{SW}=100\text{mA}$			0.4	0.5	Ω	
$R_{DS(ON)}$ of N-Channel FET	R_{NFET}	$I_{SW}=-100\text{mA}$			0.35	0.45	Ω	
SW Leakage	I_{LSW}	$V_{RUN}=0\text{V}$, $V_{SW}=0\text{V}$ or 5V , $V_{IN}=5\text{V}$			± 0.01	± 1	μA	
RUN Threshold	V_{RUN}		*	0.3	1	1.5	V	
RUN Leakage Current	I_{RUN}		*		± 0.01	± 1	μA	

Note1: Absolute Maximum Ratings are those values beyond which the life of a device may be impaired.

Note 2: The ML3406 is guaranteed to meet performance specifications from 0°C to 70°C . Specifications over the -40°C to 85°C operating temperature range are assured by design, characterization and correlation with statistical process controls.

*:apply over the full operating temperature range.

Note 3: $T_j=T_a + (PD)$ ($250^\circ\text{C}/\text{W}$)

Note 4: The ML3406 is tested in a proprietary test mode that connects V_{FB} to the output of the error amplifier.

Note 5: Dynamic supply current is higher due to the gate charge being delivered at the switching frequency.

Functional Diagram

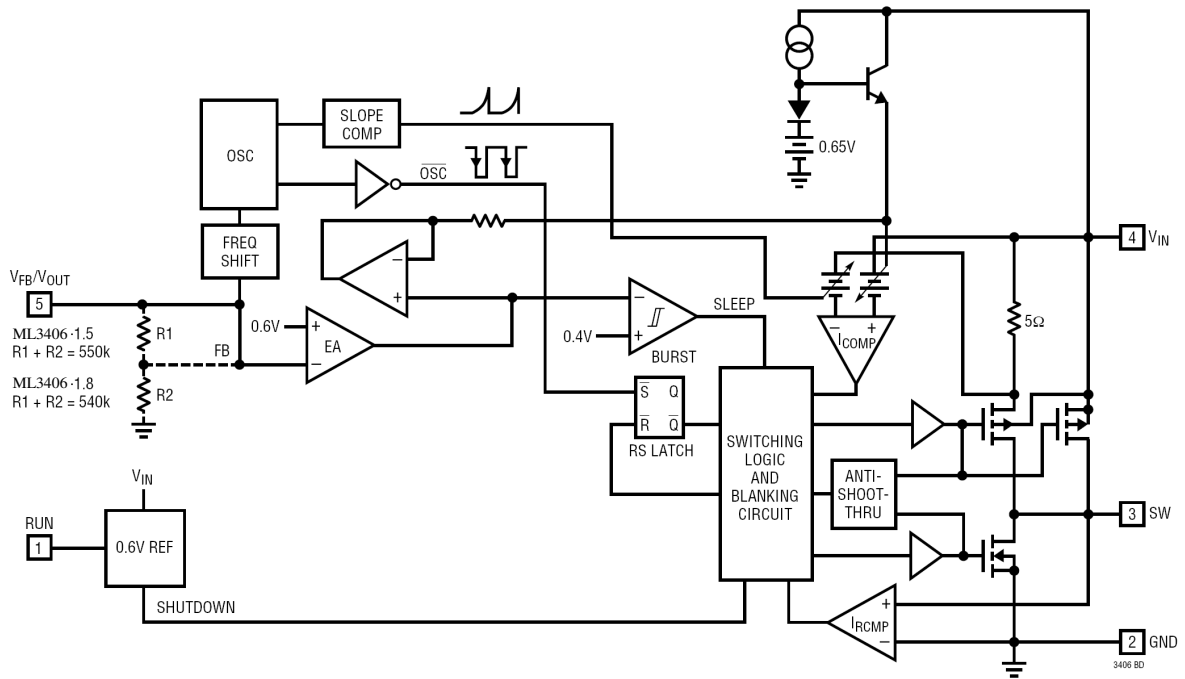

Figure 3



■ Operating

● Main Control Loop

The ML3406 uses a constant frequency, current mode step-down architecture. Both the main (P-channel MOSFET) and synchronous (N-channel MOSFET) switches are internal. During normal operation, the internal top power MOSFET is turned on each cycle when the oscillator sets the RS latch, and turned off when the current comparator, I_COMP, resets the RS latch. The peak inductor current at which I_comp resets the RS latch, is controlled by the output of error amplifier EA. When the load current increases, it causes a slight decrease in the feedback voltage, FB, relative to the 0.6V reference, which in turn , causes the EA amplifier's output voltage to increase until the average inductor current matches the new load current. While the top MOSFET is off, the bottom MOSFET is turned on until either the inductor current starts to reverse, as indicated by the current reversal comparator I_RComp, or the beginning of the next clock cycle.

● Short-Circuit Protection

When the output is shorted to ground, the frequency of the oscillator is reduced to about 210kHz, 1/7 the nominal frequency. This frequency foldback ensures that the inductor current has more time to decay, thereby preventing runaway. The oscillator's frequency will progressively increase to 1.5MHz when V_FB or V_OUT rises above 0V.

● Dropout Operation

As the input supply voltage decreases to a value approaching the output voltage, the duty cycle increases toward the maximum on-time. Further reduction of the supply voltage forces the main switch to remain on for more than one cycle until it reaches 100% duty cycle. The output voltage will then be determined by the input voltage minus the voltage drop across the P-channel MOSFET and the inductor.

An important detail to remember is that at low input supply voltages, the R_DS(ON) of the P-channel switch increases. Therefore, the user should calculate the power dissipation when the ML3406 is used at 100% duty cycle with low input voltage.

● Burst Mode Operation

The ML3406 is capable of Burst Mode operation in which the internal power MOSFETs operate intermittently based on load demand.

In Burst Mode operation, the peak current of the inductor is set to approximately 200mA regardless of the output load. Each burst event can last from a few cycles at light loads to almost continuously cycling with short sleep intervals at moderate loads. In between these burst events, the power MOSFETs and any unneeded circuitry are turned off, reducing the quiescent current to 20µA. In this sleep state, the load current is being supplied solely from the output capacitor. As the output voltage droops, the EA amplifier's output rises above the sleep threshold signaling the BURST comparator to trip and turn the top MOSFET on. This process repeats at a rate that is dependent on the load demand.

● Slope Compensation and Inductor Peak Current

Slope compensation provides stability in constant frequency architectures by preventing subharmonic oscillations at high duty cycles. It is accomplished internally by adding a compensating ramp to the inductor current signal at duty cycles in excess of 40%. Normally, this results in a reduction of maximum inductor peak current for duty cycles > 40%. However, the ML3406 uses a patent - pending scheme that counteracts this compensating ramp, which allows the maximum inductor peak current to remain unaffected throughout all duty cycles.

● Low Supply Operation

The ML3406 will operate with input supply voltages as low as 2.5V, but the maximum allowable output current is reduced at this low voltage. Figure 4 shows the reduction in the maximum output current as a function of input voltage for various output voltages.

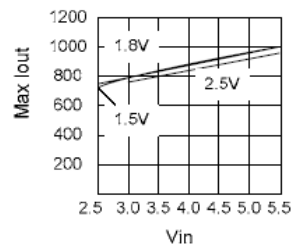

Figure 4

The basic ML3406 application circuit is shown in External component selection is driven by the load requirement and begins with the selection of L followed by C_IN and C_OUT.



■ Application Information (1)

● Inductor Selection

For most applications, the value of the inductor will fall in the range of 1μH to 4.7μH. Its value is chosen based on the desired ripple current. Large value inductors lower ripple current and small value inductors result in higher ripple currents. Higher V_{IN} or V_{OUT} also increases the ripple current as shown in equation 1. A reasonable starting point for setting ripple current is $\Delta I_L = 240\text{mA}$ (40% of 600mA)

$$\Delta I_L = \frac{1}{(f)(L)} V_{OUT} \left(1 - \frac{V_{OUT}}{V_{IN}} \right) \quad (1)$$

The DC current rating of the inductor should be at least equal to the maximum load current plus half the ripple current to prevent core saturation. Thus, a 720mA rated inductor should be enough for most applications (600mA+120mA). For better efficiency, choose a low DC-resistance inductor.

The inductor value also has an effect on Burst Mode operation. The transition to low current operation begins when the inductor current peaks fall to approximately 200mA. Lower inductor values (higher ΔI_L) will cause this to occur at lower load currents, which can cause a dip in efficiency in the upper range of low current operation. In Burst Mode operation, lower inductance values will cause the burst frequency to increase.

● Output Voltage Programming (ML3406 Only)

In the adjustable version, the output voltage is set by a resistive divider according to the following formula:

$$V_{OUT} = 0.6V \left(1 + \frac{R2}{R1} \right) \quad (2)$$

The external resistive divider is connected to the output, allowing remote voltage sensing as shown in Figure 5.

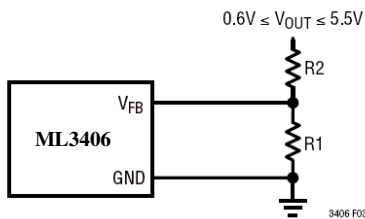

Figure 5

● C_{IN} and C_{OUT} Selection

In continuous mode, the source current of the top MOSFET is a square wave of duty cycle V_{out} / V_{in} . To prevent large voltage transients, a low ESR input capacitor sized for the maximum RMS current must be used. The maximum RMS capacitor current is given by:
 C_{IN} required

$$I_{RMS} = I_{OMAX} \frac{[V_{OUT} (V_{IN} - V_{OUT})]^{1/2}}{V_{IN}}$$

This formula has a maximum at $V_{IN} = 2V_{OUT}$, where $I_{RMS} = I_{OUT} / 2$. This simple worst-case condition is commonly used for design because even significant deviations do not offer much relief. Note that the capacitor manufacturer's ripple current ratings are often based on 2000 hours of life. This makes it advisable to further derate the capacitor, or choose a capacitor rated at a higher temperature than required. Always consult the manufacturer if there is any question.

The selection of C_{OUT} is driven by the required effective series resistance (ESR).

Typically, once the ESR requirement for C_{OUT} has been met, the RMS current rating generally far exceeds the $I_{RIPPLE(P-P)}$ requirement. The output ripple ΔV_{OUT} is determined by:

$$\Delta V_{OUT} = \Delta I_L \left(ESR + \frac{1}{8f C_{OUT}} \right)$$

Where f =operating frequency, C_{OUT} =output capacitance and ΔI_L =ripple current in the inductor. For a fixed output voltage, the output ripple is highest at maximum input voltage since ΔI_L increases with input voltage.

Aluminum electrolytic and dry tantalum capacitors are both available in surface mount configurations. In the case of tantalum, it is critical that the capacitors are surge tested for use in switching power supplies. An excellent choice is the AVX TPS series of surface mount tantalum. These are specially constructed and tested for low ESR so they give the lowest ESR for a given volume. Other capacitor types include Sanyo POSCAP, Kemet T510 and T495 series, and Sprague 593D and 595D series. Consult the manufacturer for other specific recommendations.



Application Information (2)

Using Ceramic Input and Output Capacitors

Higher values, lower cost ceramic capacitors are now becoming available in smaller case sizes. Their high ripple current, high voltage rating and low ESR make them ideal for switching regulator applications. Because the ML3406's control loop does not depend on the output capacitor's ESR for stable operation, ceramic capacitors can be used freely to achieve very low output ripple and small circuit size.

However, care must be taken when ceramic capacitors are used at the input and the output. When a ceramic capacitor is used at the input and the power is supplied by a wall adapter through long wires, a load step at the output can induce ringing at the input, VIN. At best, this ringing can couple to the output and be mistaken as loop instability. At worst, a sudden inrush of current through the long wires can potentially cause a voltage spike at VIN, large enough to damage the part.

When choosing the input and output ceramic capacitors, choose the X5R or X7R dielectric formulations. These dielectrics have the best temperature and voltage characteristics of all the ceramics for a given value and size.

Efficiency Considerations

The efficiency of a switching regulator is equal to the output power divided by the input power times 100%. It is often useful to analyze individual losses to determine what is limiting the efficiency and which change would produce the most improvement. Efficiency can be expressed as:

Efficiency = 100% - (L1 + L2 + L3 + ...)

Where L1, L2, etc. are the individual losses as a percentage of input power.

Although all dissipative elements in the circuit produce losses, two main sources usually account for most of losses in ML3406 circuits: VIN quiescent current and I^2R losses. The VIN quiescent current loss dominates the efficiency loss at very low load currents where as the I^2R loss dominates the efficiency loss at medium to high load currents. In a typical efficiency plot, the efficiency curve at very low load currents can be misleading since the actual power lost is of no consequence as illustrated in Figure 6.

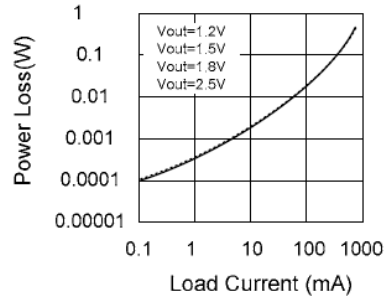

Figure 6

- 1. The VIN quiescent current is due to two components: the DC bias current as given in the electrical characteristics and the internal main switch and synchronous switch gate charge currents. The gate charge current results from switching the gate capacitance of the internal power MOSFET switches. Each time the gate is switched from high to low to high again, a packet of charge, dQ, moves from VIN to ground. The resulting dQ/dt is the current out of VIN that is typically larger than the DC bias current. In continuous mode, IGATECHG=f(QT+QB) where QT and QB are the gate charges of the internal top and bottom switches. Both the DC bias and gate charge losses are proportional to Vin and thus their effects will be more pronounced at higher supply voltages.
2. I^2R losses are calculated from the resistances of the internal switches, RSW, and external inductor RL. In continuous mode, the average output current flowing through inductor L is "chopped" between the main switch and the synchronous switch. Thus, the series resistance looking into the SW pin is a function of both top and bottom MOSFET RDS(ON) and the duty cycle (DC) as follows:

RSW = (RDS(ON)TOP)(DC)+(RDS(ON)BOT) (1-DC)

- 3. The RDS(ON) for both the top and bottom MOSFETs can be obtained from the Typical Performance Characteristics curves. Thus, to obtain I^2R losses, simply add RSW to RL and multiply the result by the square of the average output current. Other losses including CIN and COUT ESR dissipative losses and inductor core losses generally account for less than 2% total additional loss.



■ Application Information (3)

● Thermal Considerations

In most applications the ML3406 does not dissipate much heat due to its high efficiency. But, in applications where the ML3406 is running at high ambient temperature with low supply voltage and high duty cycles, such as in dropout, the heat dissipated may exceed the maximum junction temperature of the part. If the junction temperature reaches approximately 150°C, both power switches will be turned off and the SW node will become high impedance.

To avoid the ML3406 from exceeding the maximum junction temperature, the user will need to do some thermal analysis. The goal of the thermal analysis is to determine whether the power dissipated exceeds the maximum junction temperature of the part. The temperature rise is given by:

T_R = (P_D)(θ_{JA})

Where P_D is the power dissipated by the regulator and θ_{JA} is the thermal resistance from the junction of the die to the ambient temperature.

The junction temperature, T_J, is given by:

T_J = T_A + T_R

Where T_A is the ambient temperature.

As an example, consider the ML3406 in dropout at an input voltage of 2.7V, a load current of 600mA and an ambient temperature of 70°C. From the typical performance graph of switch resistance, the R_{DS(ON)} of the P-channel switch at 70°C is approximately 0.52Ω. Therefore, power dissipated by the part is:

P_D = I_{LOAD}² · R_{DS(ON)} = 187.2mW

For the SOT-23 package, the θ_{JA} is 250°C/W. Thus, the junction temperature of the regulator is:

T_J = 70°C + (0.1872)(250) = 116.8°C

Which is below the maximum junction temperature of 125°C

Note that at higher supply voltages, the junction temperature is lower due to reduced switch resistance (R_{DS(ON)}).

● Checking Transient Response

The regulator loop response can be checked by looking at the load transient response. Switching regulators take several cycles to respond to a step in load current. When a load step occurs, V_{OUT} immediately shifts by an amount equal to (ΔI_{LOAD} · ESR), where ESR is the effective series resistance of C_{OUT}, ΔI_{LOAD} also begins to charge or discharge C_{OUT}, which generates a feedback error signal. The regulator loop then acts to return V_{OUT} to its steady-state value. During this recovery time V_{OUT} can be monitored for overshoot or ringing that would indicate a stability problem. For a detailed explanation of switching control loop theory.

A second, more severe transient is caused by switching in loads with large (>1μF) supply bypass capacitors. The discharged bypass capacitors are effectively put in parallel with C_{OUT}, causing a rapid drop in V_{OUT}. No regulator can deliver enough current to prevent this problem if the load switch resistance is low and it is driven quickly. The only solution is to limit the rise time of the switch drive so that the load rise time is limited to approximately (25 · C_{LOAD}). Thus, a 10μF capacitor charging to 3.3v would require a 250μs rise time, limiting the charging current to about 130mA.

● Inductor Core Selection

Different core materials and shapes will change the size/current and price/current relationship of an inductor. Toroid or shielded pot cores in ferrite or permalloy materials are small and don't radiate much energy, but generally cost more than powdered iron core inductors with similar electrical characteristics. The choice of which style inductor to use often depends more on the price vs size requirements than on what the ML3406 requires to operate. Table 1 shows some typical surface mount inductors that work well in ML3406 applications.

■ Application Information (4)
● Recommend Surface Mount Inductors of Marker

Part Number	Value (μH)	DCR (ΩMax)	Max DC Current (A)	SIZE WxLxH (mm^3)
Sumida CDRH3D16	1.5	0.043	1.55	3.8x3.8x1.8
	2.2	0.075	1.20	
	3.3	0.110	1.10	
	4.7	0.162	0.90	
Sumida CMD4D06	2.2	0.116	0.950	3.5x4.3x0.8
	3.3	0.174	0.770	
	4.7	0.216	0.750	
Panasonic ELT5KT	3.3	0.17	1.00	4.5x5.4x1.2
	4.7	0.20	0.95	
Murata LQH32CN	1.0	0.60	1.00	2.5x3.2x2.0
	2.2	0.097	0.79	
	4.7	0.150	0.65	

● PC Board Layout Checklist

When laying out the printed circuit board, the following checklist should be used to ensure proper operation of the ML3406. These items are also illustrated graphically in Figures 7 and 8. Check the following in your layout:

1. The power traces, consisting of the GND trace, the SW trace and the V_{IN} trace should be kept short, direct and wide.
2. Does the V_{FB} pin connect directly to the feedback resistors? The resistive divider $R1/R2$ must be connected between the (+) plate of C_{OUT} and ground.
3. Does the (+) plate of C_{IN} connect to V_{IN} as closely as possible? This capacitor provides the AC current to the internal power MOSFETs.
4. Keep the switching node, SW, away from the sensitive V_{FB} node.
5. Keep the (-)plates of C_{IN} and C_{OUT} as close as possible.

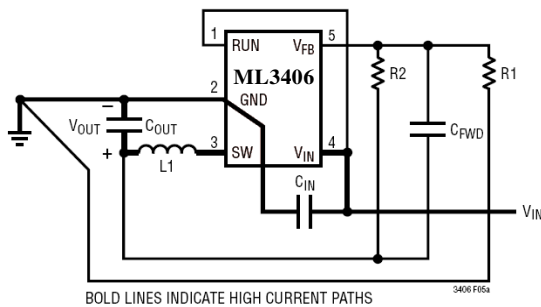
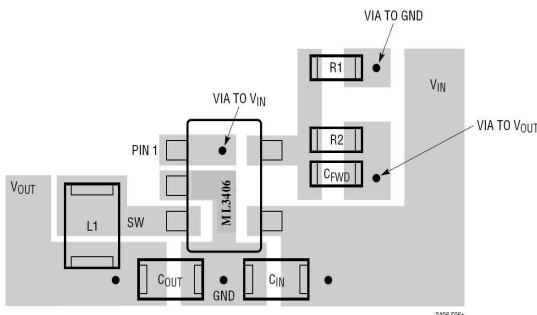
Figure 7

Figure 8 ML3406 Layout Diagram

■ Application Information (5)
● Design Example

As a design example, assume the ML3406 is used in a single Lithium - on battery – powered cellular phone application. The V_{IN} will be operation from maximum of 4.2V down to about 2.7V. The load current requirement is a maximum of 0.6A but most of the time it will be in standby mode, requiring only 2mA. Efficiency at both low and high load currents is important. Output voltage is 2.5V. With this information we can calculate L using equation (1),

$$L = \frac{1}{f(\Delta I_L)} V_{OUT} \left(1 - \frac{V_{OUT}}{V_{IN}} \right) \quad (3)$$

Substituting $V_{OUT} = 2.5V$, $V_{IN} = 4.2V$, $\Delta I_L = 240mA$ and $f = 1.5MHz$ in equation (3) gives:

$$L = \frac{2.5V}{1.5MHz (240mA)} \left(1 - \frac{2.5V}{4.2V} \right) = 2.81\mu H$$

A 2.2 μH inductor works well for this application. For best efficiency choose a 720mA or greater inductor with less than 0.2 Ω series resistance

C_{IN} will require and RMS current rating of at least $0.3A \approx I_{LOAD(MAX)} / 2$ at temperature and C_{OUT} will require and ESR of less than 0.25 Ω . In most cases, a ceramic capacitor will satisfy this requirement.

For the feedback resistors, choose $R1=316k$. $R2$ can then be calculated from equation (2) to be:

$$R2 = \left(\frac{V_{OUT}}{0.6} - 1 \right) R1 = 1000k$$

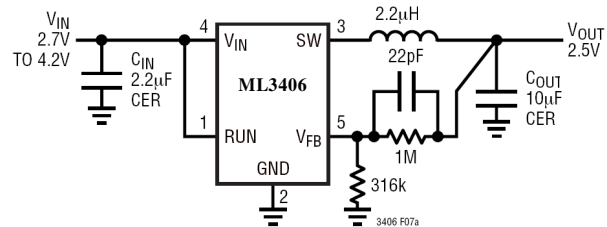
Figure 9
● Recommend Components

Component	Rating	Item	Maker
Coil	L=2.2uH	LQH32CN2R2M33	Murata
	L=4.7uH	LQH32CN2R7M34	
Capacitor	Cin=2.2uF Ceramic	LMK212BJ225MG	Tayo Yuden
	Cin=4.7uF Ceramic	JMK212BJ475MG	
	Cin=10uF Ceramic	JMK316BJ106ML	
	Cin=100uF Ceramic	4TPB100M	Sanyo POSCAP

■ Typical Application Circuit

Tiny 3.3V/600mA Buck Regulator

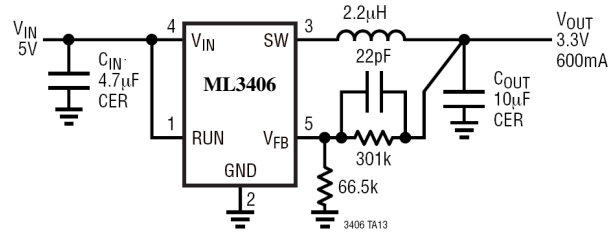
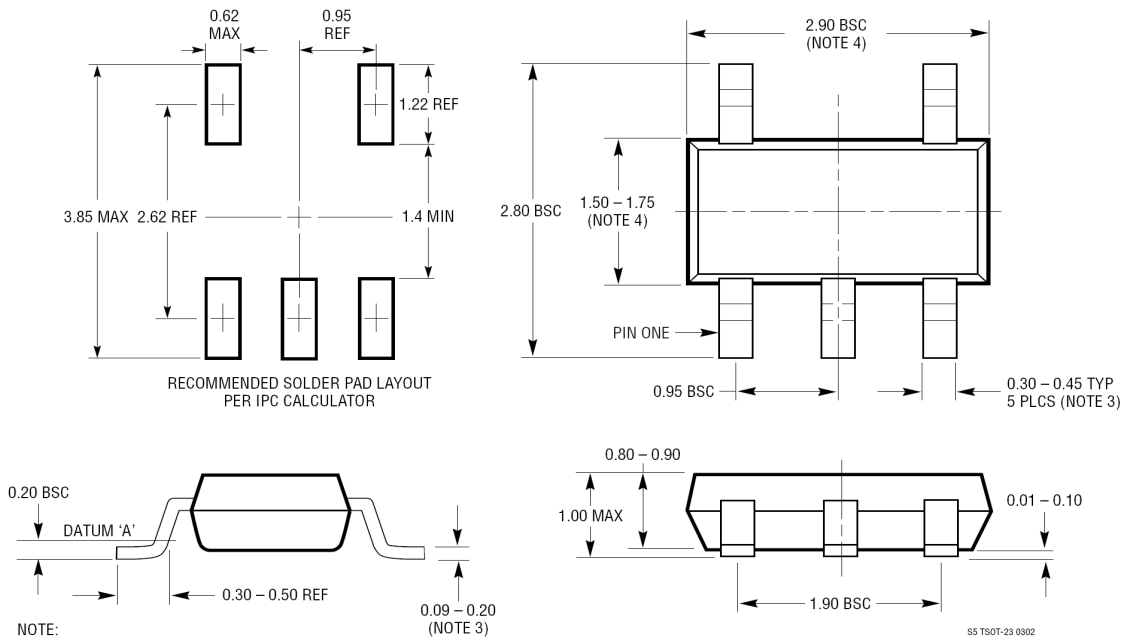

Figure 10



■ PACKAGE DESCRIPTION



- NOTE:
1. DIMENSIONS ARE IN MILLIMETERS
 2. DRAWING NOT TO SCALE
 3. DIMENSIONS ARE INCLUSIVE OF PLATING
 4. DIMENSIONS ARE EXCLUSIVE OF MOLD FLASH AND METAL BURR
 5. MOLD FLASH SHALL NOT EXCEED 0.254mm
 6. JEDEC PACKAGE REFERENCE IS MO-193

DISCLAIMER:

The information presented in this document does not form part of any quotation or contract, is believed to be accurate and reliable and may be changed without notice. No liability will be accepted by the publisher for any consequence of its use.