

ML65 Series DC-DC Converter

❖ *General Description*

The ML65 is a group of PWM Step-up DC/DC converter IC with ultra-low supply current by CMOS process.

It consists of an oscillator, a PWM control circuit, a Lx switch driver transistor, a reference voltage unit, an error amplifier for voltage detection and an Lx switch protection circuit. It is suitable for use with battery-powered instruments with low noise and ultra low supply current.

❖ *Features*

- Small number of external components: inductor, diode and capacitor.
- Ultra low input current : Typical 6 μ A
- Output Voltage Accuracy : +/- 2.5 %
- Low ripple and noise
- Low startup voltage : Max 0.9V (with 1mA input)
- High Efficiency: Typical 80%
- Package Available:
SOT-89 (500mW), SOT-23 (150mW) & TO-92 (300mW)

❖ *Application*

- ◆ *Power Source of Portable Products*
- ◆ *Palmtops*
- ◆ *Portable Cameras and Video Recorders*
- ◆ *Wireless mouse and keyboard*

ML65 Version	Package Designator	Package	Switching Transistor	CE Function	VDD Pin	FB Pin	Features
ML65A	M	SOT23-3	Build-in Transistor	No	No	No	Lx
	P	SOT89-3					
	T	TO-92					
ML65C	M	SOT23-5	Build-in Transistor	Yes	No	No	Lx+CE
	P	SOT89-5					

❖ *Ordering Information*

Designator	Description
a	Version
b	Output Voltage eg. 30=3.0V 33=3.3V 50=5.0V
c	Package Type P = SOT-89 M = SOT-23
d	Device Orientation R = Embossed Tape (Orientation of Device : Right) L = Embossed Tape (Orientation of Device : Left) B = Bag (TO-92)

ML65XXXXX
↑ ↑ ↑ ↑
a b c d

Marking:

SOT23:

ML65Cseries

	Marking	Description
ML65C33MRG	41XX	XX = Production Date Code e.g. B2
ML65C50MRG	42XX	

ML65C33MRG

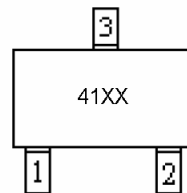

SOT-23 (Top View)

e.g.

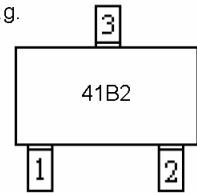

SOT-23 (Top View)

ML65C50MRG

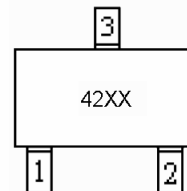

SOT-23 (Top View)

e.g.

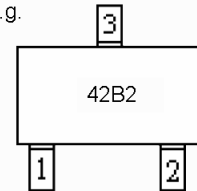

SOT-23 (Top View)

SOT89:

ML65A series

Designator	Description
1, 2	Year Code e.g. 05 = Year 2005
3, 4	Week Code e.g. 30 = Week 30
5, 6	Output Voltage e.g. 30 = 3.0 V

ML65A

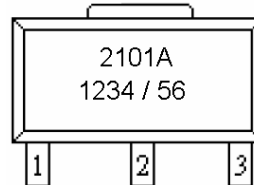

SOT-89 (Top View)

e.g.

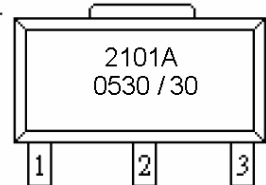

SOT-89 (Top View)

❖ **ML65A**

◆ **Pin Configuration**

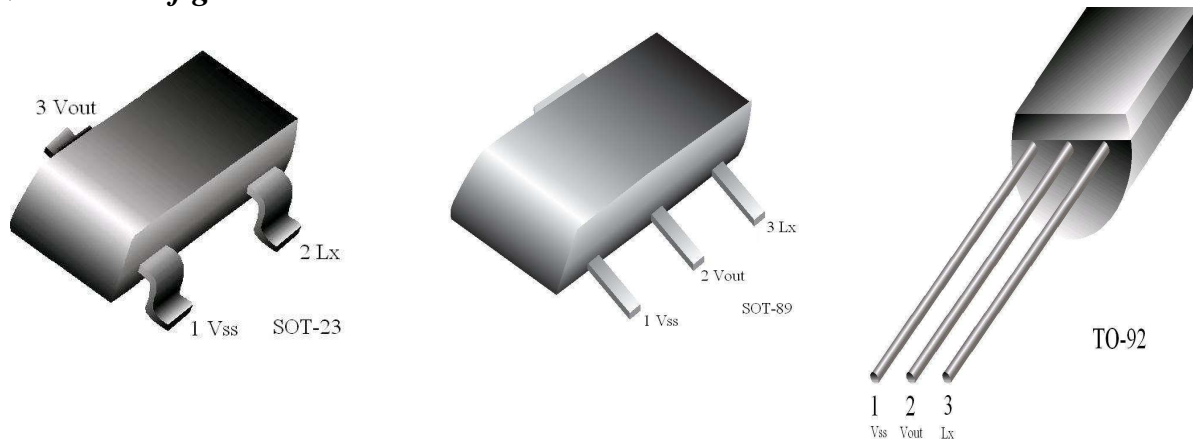

Package Pin Number			Pin Name	Function
SOT23-3	SOT89-3	TO-92		
1	1	1	V _{SS}	Ground
3	2	2	V _{OUT}	Output Voltage monitor, Internal IC Power Supply
2	3	3	L _X	Switch

◆ **Block Diagram**

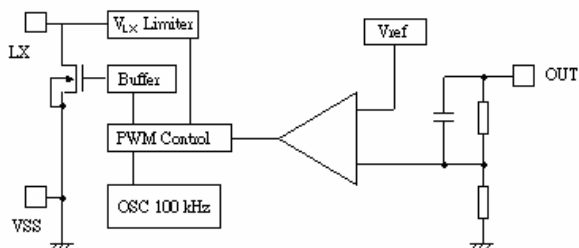

◆ **Typical Applications**

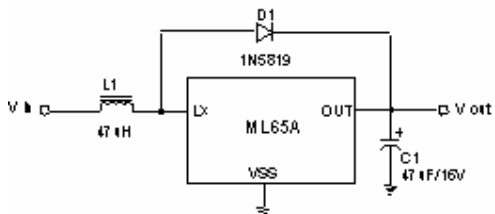

❖ **ML65C**

◆ **Pin Configuration**

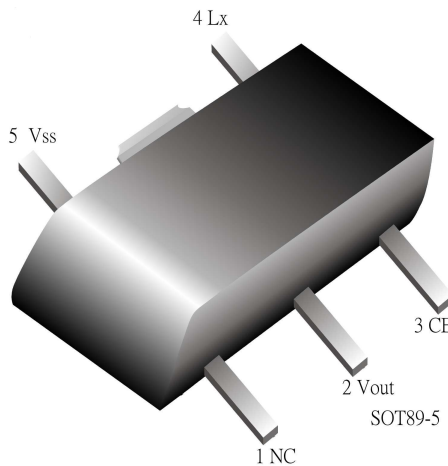
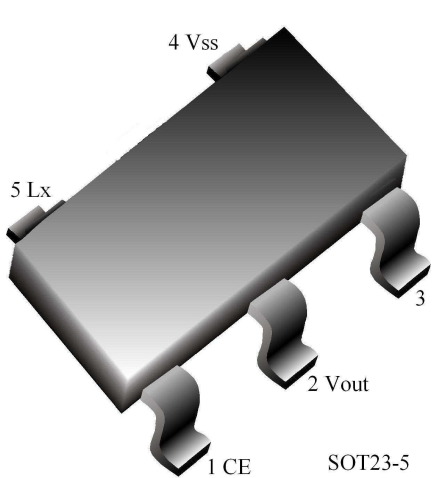

Package Pin Number		Pin Name	Function
SOT23-5	SOT89-5		
4	5	V _{SS}	Ground
2	2	V _{OUT}	Output Voltage monitor, Internal IC Power Supply
5	4	LX	Switch
1	3	CE	Chip Enable
3	1	NC	NC

◆ **Block Diagram**

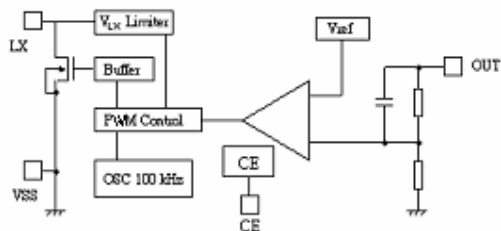

◆ **Typical Applications**

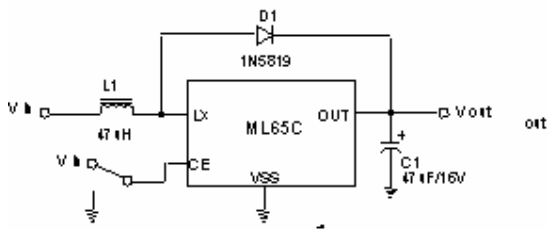

❖ Absolute Maximum Ratings

Parameter		Symbol	Ratings	Units
Input Voltage		V_{IN}	10	V
V_{DD} Input Voltage		V_{DD}	10	V
Lx Pin Voltage		V_{LX}	10	V
EXT Pin Voltage		V_{EXT}	-0.3 ~ $V_{OUT} + 0.3$	V
CE Pin Voltage		V_{CE}	-0.3 ~ $V_{OUT} + 0.3$	V
Lx Pin Current		I_{LX}	600	mA
EXT Pin Current		I_{EXT}	± 30	mA
Continuous Total Power Dissipation	SOT-89	Pd	500	mW
	TO-92		300	
	SOT-23		150	
Operating Ambient Temperature		T_{opr}	-25 ~ +85	$^{\circ}C$
Storage Temperature		T_{stg}	-40 ~ +125	$^{\circ}C$

❖ Electrical Characteristics

$V_{IN} = V_{OUT} * 0.6$, $V_{SS} = 0V$, $I_{OUT} = 10mA$, $T_a = 25^{\circ}C$, unless otherwise specified.

Parameter	Symbol	Conditions	Min	Typ	Max	Units
Output Voltage	V_{OUT}		$V_{out} * 0.975$	V_{out}	$V_{out} * 1.025$	V
Input Voltage	V_{IN}				8	V
Startup Voltage	V_{START}	$I_{OUT} = 1mA$, $V_{IN}: 0 \rightarrow 2V$		0.8	0.9	V
Hold-on Voltage	V_{HOLD}	$I_{OUT} = 1mA$, $V_{IN}: 2 \rightarrow 0V$	0.7			V
Supply Current 1	I_{DD1}	No external component, $V_{IN} = V_{OUT} * 0.95$		30~70		μA
Supply Current 2	I_{DD2}	$V_{IN} = V_{IN} + 0.5V$		11~26		μA
Lx Switching Current	I_{LX}	$V_{LX} = 0.4V$, $V_{IN} = V_{OUT} * 0.95$		250		mA
Lx Leakage Current	I_{LXLEAK}	$V_{IN} = V_{LX} = 6.0V$			0.5	μA
EXT "High" On Current	I_{EXTH}	No external component, $V_{IN} = V_{OUT} * 0.95$, $V_{EXT} = V_{OUT} - 0.4V$		-5.5		mA
EXT "Low" On Current	I_{EXTL}	No external component, $V_{IN} = V_{OUT} * 0.95$, $V_{EXT} = 0.4V$		13		mA
CE "High" Voltage	V_{CEH}	$V_{IN} = V_{OUT} * 0.95$	0.7			V
CE "Low" Voltage	V_{CEL}	$V_{IN} = V_{OUT} * 0.95$			0.2	V
CE "High" Current	I_{CEH}	$V_{OUT} = 6.0V$, $V_{CE} = 6.0V$			0.25	μA
CE "Low" Current	I_{CEL}	$V_{OUT} = 6.0V$, $V_{CE} = 0.0V$			-0.25	μA
Oscillator Frequency	F_{OSC}			100		KHz
Duty Cycle	MAXDTY		80	87	92	%
Efficiency	EFF			85		%
Slow-Start Time	T_{SS}		5	15	25	ms

Note : 1. Schokkty diode: 1N5817 or 1N5819 (forward voltage drop : 0.2V)

2. Inductor : 47 μH (ESR < 0.5 Ω)

3. Capacitor : Tantalum type, 47 μF

❖ Electrical Characteristics
ML65A30 $V_{OUT} = 3.0V$ $V_{IN} = 1.8V$, $I_{OUT} = 10mA$, $T_a = 25^{\circ}C$, unless otherwise provided.

Parameter	Symbol	Conditions	Min	Typ	Max	Units
Output Voltage	V_{OUT}		2.925	3.000	3.075	V
Input Voltage	V_{IN}				8	V
Startup Voltage	V_{START}	$I_{OUT} = 1mA$		0.8	0.9	V
Hold-on Voltage	V_{HOLD}	$I_{OUT} = 1mA$	0.7			V
Supply Current 1	I_{DD1}	$V_{IN} = 2.85V$		30		μA
Supply Current 2	I_{DD2}	$V_{IN} = 3.05V$		11		μA
Lx Switching Current	I_{LX}	$V_{LX} = 0.4V$, $V_{IN} = 2.85V$		250		mA
Lx Leakage Current	I_{LXLEAK}	$V_{IN} = 6.0V$, $V_{LX} = 6.0V$			0.5	μA
Oscillator Frequency	F_{OSC}			100	150	KHz
Oscillator Duty Cycle	MAXDTY		80	87	92	%
Efficiency	EFF			85		%
Slow –Start Time	T_{SS}		5	15	25	ms

ML65A33 $V_{OUT} = 3.3V$ $V_{IN} = 2.0V$, $I_{OUT} = 10mA$, $T_a = 25^{\circ}C$, unless otherwise provided.

Parameter	Symbol	Conditions	Min	Typ	Max	Units
Output Voltage	V_{OUT}		3.218	3.300	3.383	V
Input Voltage	V_{IN}				8	V
Startup Voltage	V_{START}	$I_{OUT} = 1mA$		0.8	0.9	V
Hold-on Voltage	V_{HOLD}	$I_{OUT} = 1mA$	0.7			V
Supply Current 1	I_{DD1}	$V_{IN} = 3.135V$		33		μA
Supply Current 2	I_{DD2}	$V_{IN} = 3.35V$		12		μA
Lx Switching Current	I_{LX}	$V_{LX} = 0.4V$, $V_{IN} = 3.135V$		260		mA
Lx Leakage Current	I_{LXLEAK}	$V_{IN} = 6.0V$, $V_{LX} = 6.0V$			0.5	μA
Oscillator Frequency	F_{OSC}			100	150	KHz
Oscillator Duty Cycle	MAXDTY		80	87	92	%
Efficiency	EFF			85		%
Slow –Start Time	T_{SS}		5	15	25	ms

ML65A50 $V_{OUT} = 5.0V$ $V_{IN} = 3.0V$, $I_{OUT} = 10mA$, $T_a = 25^{\circ}C$, unless otherwise provided.

Parameter	Symbol	Conditions	Min	Typ	Max	Units
Output Voltage	V_{OUT}		4.875	5.000	5.125	V
Input Voltage	V_{IN}				8	V
Startup Voltage	V_{START}	$I_{OUT} = 1mA$		0.8	0.9	V
Hold-on Voltage	V_{HOLD}	$I_{OUT} = 1mA$	0.7			V
Supply Current 1	I_{DD1}	$V_{IN} = 4.75V$		70		μA
Supply Current 2	I_{DD2}	$V_{IN} = 5.05V$		26		μA
Lx Switching Current	I_{LX}	$V_{LX} = 0.4V$, $V_{IN} = 4.75V$		290		mA
Lx Leakage Current	I_{LXLEAK}	$V_{IN} = 6.0V$, $V_{LX} = 6.0V$			0.5	μA
Oscillator Frequency	F_{OSC}			100	150	KHz
Oscillator Duty Cycle	MAXDTY		80	87	92	%
Efficiency	EFF			85		%
Slow –Start Time	T_{SS}		5	15	25	ms

❖ *Application Notes*

1. It is recommended to use capacitor with a capacity of 10uF or more for good frequency characteristics, otherwise it will lead to high output ripple. Tantalum type capacitor is recommended. As there may be the case where a spike-shaped high voltage is generated by the inductor when Lx transistor is turned off, the operating voltage of capacitor should be at least three times of the output set voltage so as to avoid over-voltage damage.
2. It is recommended to use inductor has sufficiently small d.c. resistance, large allowable current and hardly reaches magnetic saturation. When the inductance of inductor is small, there may be the case that the inductor current exceeds the absolute maximum ratings at the maximum load condition.
3. It is recommended to place external components as close as possible to the DC/DC converter so as to minimize the interconnection parasitic between components and DC/DC converter, especially for the capacitor connected to V_{OUT} pin. It is recommended to place 0.1uF ceramic capacitor between V_{OUT} pin and V_{SS} pin.
4. It is recommended to provide sufficient grounding for V_{SS} pin. This will help to stable the zero level within DC/DC converter induced by the switching current level variation during operation. And the insufficient grounding may result in unstable operation of DC/DC converter.

The information presented in this document does not form part of any quotation or contract, is believed to be accurate and reliable and may be changed without notice. No liability will be accepted by the publisher for any consequence of its use.