

M-Pulse Microwave

Silicon Bipolar MMIC Cascadable Amplifier

MP4TD0410

Features

- Cascadable 50Ω Gain Block
- 3dB Bandwidth: DC to 3.0 GHz
- 9.0 dB Typical Gain @ 1.0 GHz
- Unconditionally Stable ($k > 1$)
- Hermetic Gold-Ceramic Microstrip Package
- Tape and Reel Packaging Available

Description

M-Pulse's MP4TD0410 is a high performance silicon bipolar MMIC housed in a hermetic high reliability package for surface mount usage. The MP4TD0410 is useful where a general purpose 50Ω gain block with moderate (+16 dBm) gain compression is required. Typical applications include narrow and wide band IF and RF amplifiers in industrial and military applications.

The MP4TD0410 is fabricated using a 10 GHz f_T silicon bipolar technology that features gold metalization and IC passivation for increased performance and reliability.

Gold-Ceramic Microstrip Package Outline^{1,2}

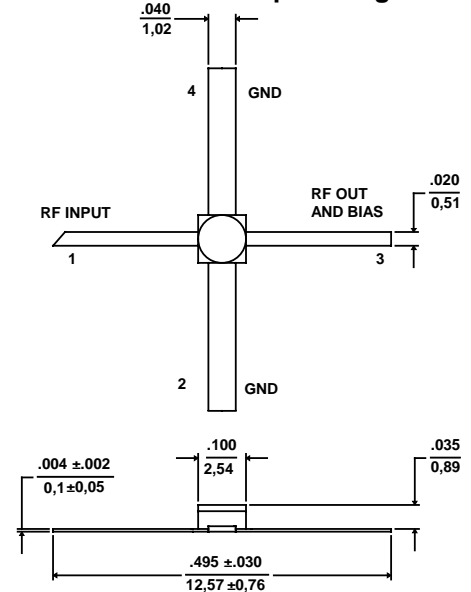

Notes: (unless otherwise specified)

1. Dimensions are in / mm
2. Tolerance: in .xxx = ±.005; mm .xx = ±.13

TYPICAL POWER GAIN vs FREQUENCY

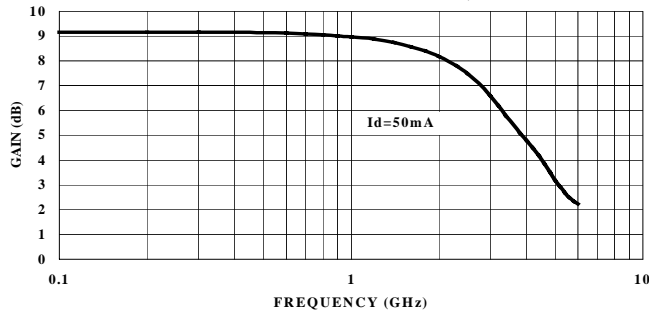

Pin Configuration

Pin Number	Pin Description
1	RF Input
2 & 4	AC/DC Ground
3	RF Output and DC Bias

Ordering Information

Model No.	Package
MA4TD0410	Hermetic Ceramic
MA4TD0410T	Tape and Reel

Electrical Specifications @ $T_A = +25^\circ\text{C}$, $I_d = 50 \text{ mA}$, $Z_0 = 50\Omega$

Symbol	Parameters	Test Conditions	Units	Min.	Typ.	Max.
Gp	Power Gain ($ S_{21} ^2$)	$f = 0.1 \text{ GHz}$	dB	8.0	9.0	9.5
ΔG_p	Gain Flatness	$f = 0.1 \text{ to } 2.0 \text{ GHz}$	dB	-	±0.6	±1.0
$f_3 \text{ dB}$	3 dB Bandwidth	-	GHz	-	3.0	-
SWR _{in}	Input SWR	$f = 0.1 \text{ to } 3.0 \text{ GHz}$	-	-	1.5	-
SWR _{out}	Output SWR	$f = 0.1 \text{ to } 3.0 \text{ GHz}$	-	-	1.6	-
P _{1dB}	Output Power @ 1 dB Gain Compression	$f = 1.0 \text{ GHz}$	dBm	-	12.5	-
NF	50 Ω Noise Figure	$f = 1.0 \text{ GHz}$	dB	-	6.2	-
IP ₃	Third Order Intercept Point	$f = 1.0 \text{ GHz}$	dBm	-	25.5	-
t _D	Group Delay	$f = 1.0 \text{ GHz}$	ps	-	125	-
V _d	Device Voltage	-	V	4.75	5.25	5.75
dV/dT	Device Voltage Temperature Coefficient	-	mV/°C	-	-8.0	-

Specification Subject to Change Without Notice

Absolute Maximum Ratings¹

Parameter	Absolute Maximum
Device Current	100 mA
Power Dissipation ^{2,3}	650 mW
RF Input Power	+13 dBm
Junction Temperature	150°C
Storage Temperature	-65°C to +200°C

Thermal Resistance: $\theta_{jC} = 140 \text{ }^\circ\text{C/W}$

1. Exceeding these limits may cause permanent damage.
2. Case Temperature (T_c) = 25 °C.
3. Derate at 7.1 mW/°C for $T_c > 109^\circ\text{C}$.

Typical Bias Configuration

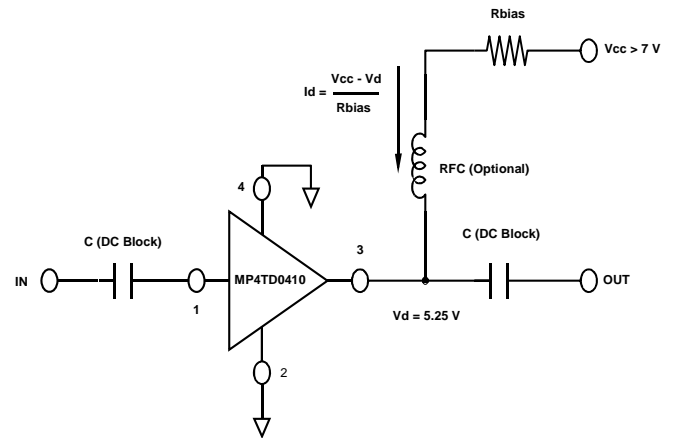

Typical Performance Curves @ $I_d = 50 \text{ mA}$, $T_A = +25^\circ\text{C}$ (unless otherwise noted)

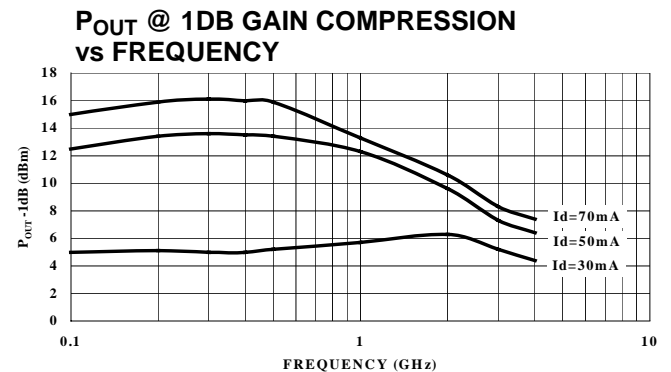
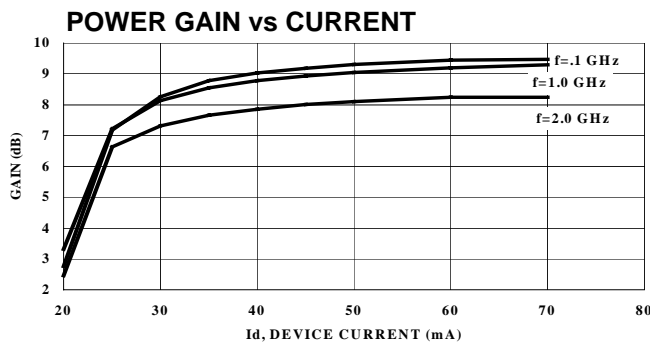
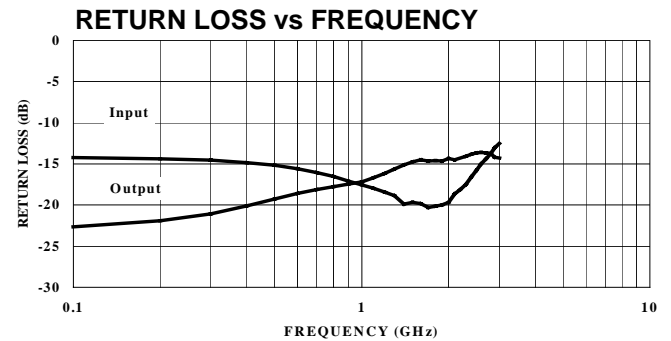
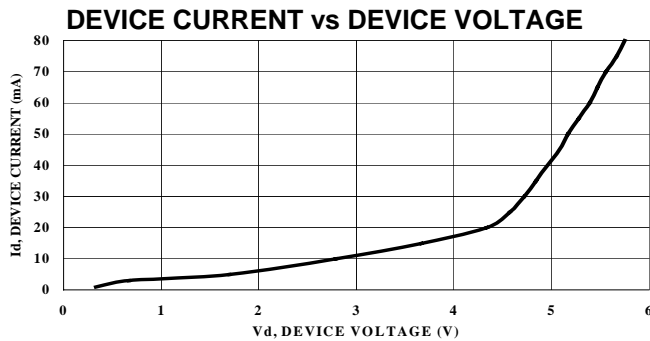

Specification Subject to Change Without Notice

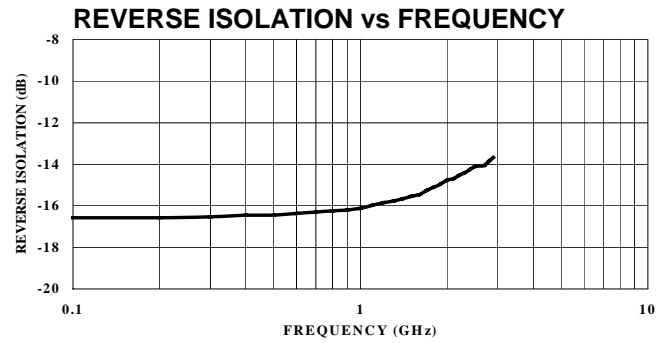
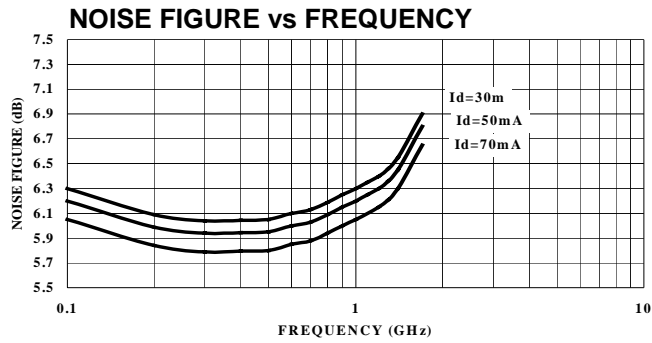

Typical Scattering Parameters
 $Z_0 = 50\Omega$, $T_A = +25^\circ\text{C}$, $I_D = 50\text{ mA}$

Frequency (GHz)	S ₁₁		S ₂₁		S ₁₂		S ₂₂	
	Mag.	Angle	Mag.	Angle	Mag.	Angle	Mag	Angle
0.1	0.197	177.2	2.87	175.8	0.147	2.0	0.073	-14.7
0.2	0.191	175.3	2.87	171.6	0.148	3.9	0.080	-29.5
0.3	0.186	173.1	2.87	167.5	0.148	5.4	0.088	-42.7
0.4	0.181	171.2	2.87	163.2	0.150	7.0	0.098	-53.0
0.5	0.174	169.2	2.87	158.9	0.150	8.8	0.109	-61.5
0.6	0.165	167.3	2.87	154.6	0.152	10.5	0.117	-69.7
0.7	0.156	135.7	2.85	150.5	0.153	12.1	0.123	-76.7
0.8	0.140	163.9	2.84	140.3	0.153	13.4	0.128	-88.7
0.9	0.139	162.9	2.83	142.2	0.154	15.5	0.133	-90.7
1.0	0.132	162.0	2.83	138.1	0.156	17.2	0.137	-98.6
1.5	0.103	173.1	2.69	118.2	0.167	24.0	0.183	-128.2
2.0	0.100	174.5	2.52	100.0	0.181	29.8	0.185	-147.1
2.5	0.162	174.9	2.35	84.3	0.194	33.5	0.208	-163.5
3.0	0.236	165.9	2.19	73.2	0.207	37.6	0.194	-173.5

Specification Subject to Change Without Notice