

# Data Sheet

Rev. 1.00 / December 2011

# ZLED7015

1.0MHz Boost Converter with Internal 35V Switch



# ZLED7015

## 1.0MHz Boost Converter with Internal 35V Switch



The Analog Mixed Signal Company



### Brief Description

The ZLED7015, one of our ZLED family of LED control ICs, is a constant current boost converter with an internal high-power 35V switch. It is optimal for driving multiple white LEDs connected in series so that the LED current is uniform for better brightness and color control. It can also drive devices that require a constant voltage and is capable of operating efficiently with voltage supplies ranging from 6VDC to 30VDC. It is ideal for diverse lighting applications requiring low supply voltages such as SELV applications. Typically, smaller, less expensive external components can be used since the ZLED7015 switches at 1.0MHz (typical).

The ZLED7015 output current is adjustable via an external current sense resistor  $R_S$  connected from the FB pin to ground.

The ZLED7015 improves efficiency and minimizes power losses in the current setting resistor  $R_S$  by use of an internal 0.3V feedback reference voltage.

Dimming can be controlled using a pulse-width modulation (PWM) waveform or a DC voltage applied to the FB pin.

The ZLED7015 provides a “soft-start” function to prevent excessive in-rush current on start-up and ensures a controlled rise of the output voltage.

Over-voltage protection is adjustable via external resistors  $R_1$  and  $R_2$ .

### Features

- Integrated 35V power switch
- Wide input range: 6VDC to 30VDC
- Over-temperature protection
- Over-voltage (open LED string) protection adjusted via external resistor divider
- Under-voltage lockout ensures reliable circuit operation
- Control of output current during start-up via internal “soft-start”
- Switching frequency: 1.0MHz
- Single pin on/off or brightness control via PWM, microcontroller, or DC voltage control signal input
- MSOP-10 package

### Benefits

- High efficiency: up to 95% efficiency
- Few small, low-profile components needed for operation
- Small form-factor package

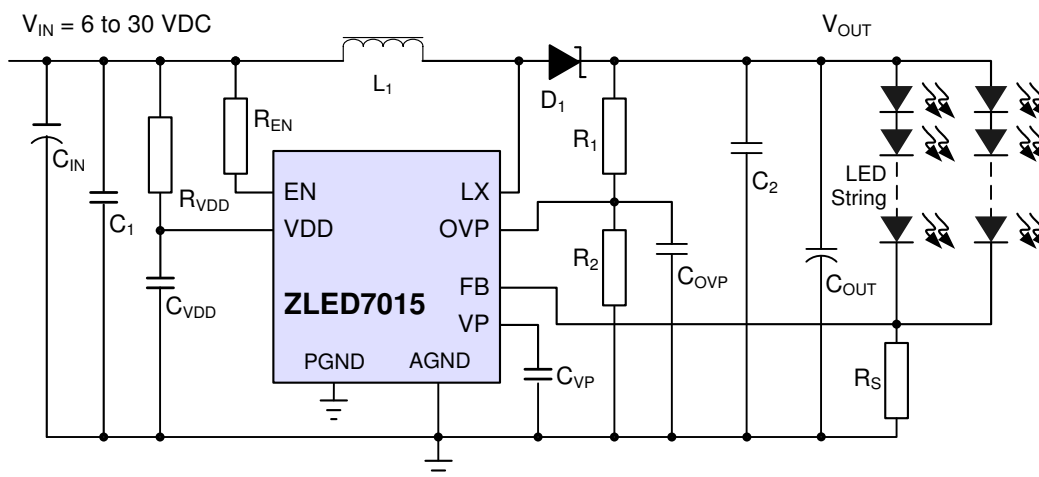
### Available Support

- Evaluation Kit

### Physical Characteristics

- Operating temperature: -40°C to 85°C
- RoHS-compliant

### ZLED7015 Typical Application Circuit



# ZLED7015

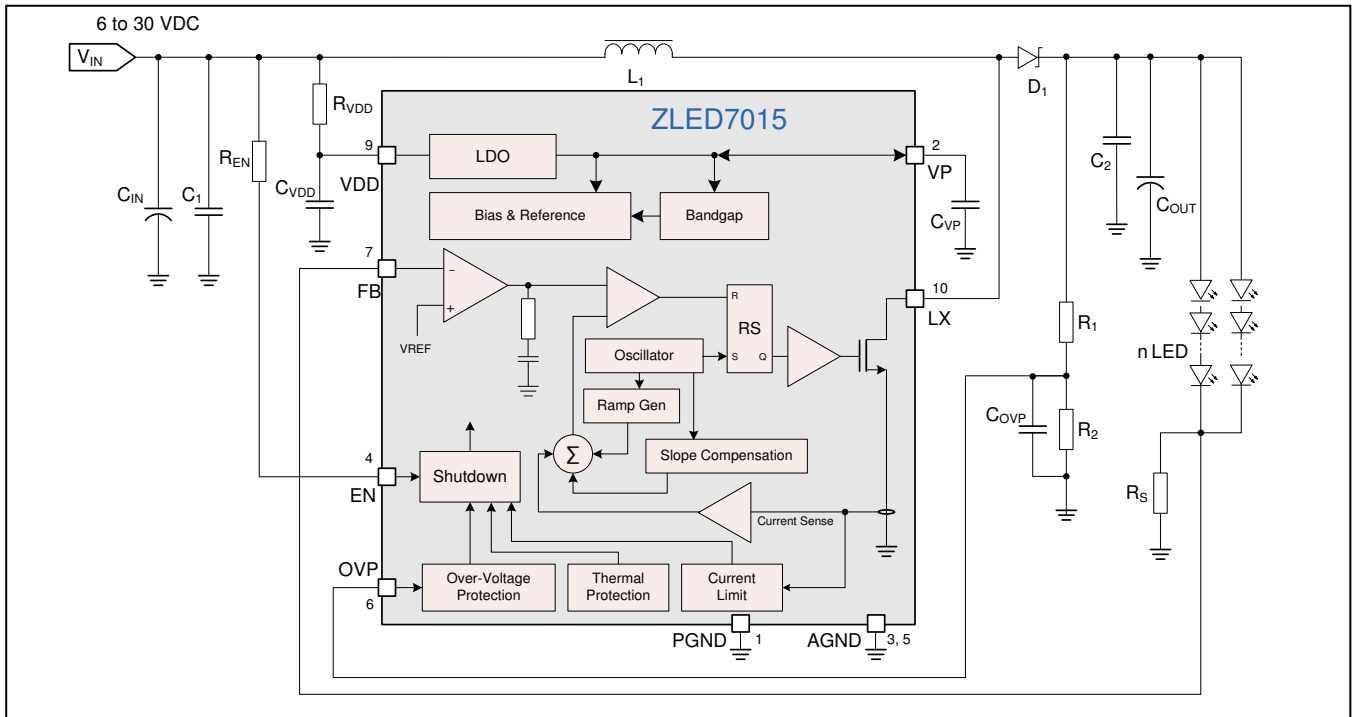
1.0MHz Boost Converter with Internal 35V Switch



The Analog Mixed Signal Company



## ZLED7015 Block Diagram



### Typical Applications

- ❖ Low-Voltage Retro-fit Lighting
- ❖ MR16 Lights
- ❖ SELV Lighting
- ❖ Signage and Outdoor Lighting
- ❖ Architectural/Building Lighting
- ❖ Replacement Tubes
- ❖ LED Backlighting
- ❖ General Purpose Low-Voltage Industrial and Consumer Applications

## Ordering Information

Product Sales Code	Description	Package
ZLED7015-ZI1R	ZLED7015 – 1.0MHz Boost Converter with Internal 35V Switch	MSOP-10 (Tape & Reel)
ZLED7015KIT-E1	ZLED7015-E1 Evaluation Board, 1 ZLED-PCB10, and 5 ZLED7015 ICs	Kit

## Sales and Further Information

[www.zmdi.com](http://www.zmdi.com)

[LED\\_Drivers@zmdi.com](mailto:LED_Drivers@zmdi.com)

Zentrum Mikroelektronik  
Dresden AG  
Grenzstrasse 28  
01109 Dresden  
Germany

ZMD America, Inc.  
275 South 5th Avenue  
Pocatello, ID 83201  
USA

Zentrum Mikroelektronik  
Dresden AG, Japan Office  
2nd Floor, Shinbashi Tokyu Bldg.  
4-21-3, Shinbashi, Minato-ku  
Tokyo, 105-0004  
Japan

ZMD FAR EAST, Ltd.  
3F, No. 51, Sec. 2,  
Keelung Road  
11052 Taipei  
Taiwan

Zentrum Mikroelektronik  
Dresden AG, Korean Office  
POSCO Centre Building  
West Tower, 11th Floor  
892 Daechi, 4-Dong,  
Kangnam-Gu  
Seoul, 135-777  
Korea

Phone +49.351.8822.7.533  
Fax +49.351.8822.8.7533

Phone +1.208.478.7200  
Fax +1.208.478.7200

Phone +81.3.6895.7410  
Fax +81.3.6895.7301

Phone +886.2.2377.8189  
Fax +886.2.2377.8199

Phone +82.2.559.0660  
Fax +82.2.559.0700

**DISCLAIMER:** This information applies to a product under development. Its characteristics and specifications are subject to change without notice. Zentrum Mikroelektronik Dresden AG (ZMD AG) assumes no obligation regarding future manufacture unless otherwise agreed to in writing. The information furnished hereby is believed to be true and accurate. However, under no circumstances shall ZMD AG be liable to any customer, licensee, or any other third party for any special, indirect, incidental, or consequential damages of any kind or nature whatsoever arising out of or in any way related to the furnishing, performance, or use of this technical data. ZMD AG hereby expressly disclaims any liability of ZMD AG to any customer, licensee or any other third party, and any such customer, licensee and any other third party hereby waives any liability of ZMD AG for any damages in connection with or arising out of the furnishing, performance or use of this technical data, whether based on contract, warranty, tort (including negligence), strict liability, or otherwise.

# ZLED7015

## 1.0MHz Boost Converter with Internal 35V Switch



The Analog Mixed Signal Company



### Contents

1	IC Characteristics	6
1.1	Absolute Maximum Ratings	6
1.2	Operating Conditions	6
1.3	Electrical Parameters	7
1.4	Typical Operating Characteristics	8
1.5	Characteristic Waveforms	10
2	Circuit Description	12
2.1	EN Pin, VP Pin, and Soft-Start Function	12
2.2	Output Current Control	12
2.2.1	Output Current and $R_S$	12
2.2.2	Dimming via External DC Voltage Control	13
2.2.3	Dimming via PWM Control	14
2.2.4	Microcontroller LED Control	15
2.2.5	Constant Voltage Application	15
3	Application Circuit Design	17
3.1	External Component – $R_S$	17
3.2	External Component – Inductor $L_1$	17
3.3	External Components – Input Decoupling Capacitors $C_1$ and $C_{IN}$	17
3.4	External Component – Output Capacitors $C_2$ and $C_{OUT}$	17
3.5	External Component – Diode $D_1$	17
3.6	Additional External Components	17
4	Operating Conditions	18
4.1	Under-Voltage Lockout	18
4.2	Over-Voltage Threshold and Open-Circuit Protection	18
4.3	Over-Temperature Protection	18
5	ESD/Latch-Up-Protection	19
6	Pin Configuration and Package	19
7	Layout Requirements	21
7.1	General Considerations and Ground Traces	21
7.2	Layout Considerations for $C_1$ , $C_{IN}$ , $C_2$ and $C_{OUT}$	21
7.3	Layout Considerations for the EN Pin	21
7.4	Layout Considerations for the LX Pin, $L_1$ External Coil, and $D_1$ Diode	21
7.5	Layout Considerations for the External Current Sense Resistor ( $R_S$ )	21
7.6	Layout Considerations for $C_{VP}$ and $C_{VDD}$	21
7.7	Layout Considerations for the Thermal Pad	21
8	Glossary of Terms	22
9	Ordering Information	22
10	Document Revision History	22

# ZLED7015

1.0MHz Boost Converter with Internal 35V Switch



The Analog Mixed Signal Company



## List of Figures

Figure 1.1	$I_{OUT}$ vs. $V_{IN}$ with $R_S = 0.42\Omega$ .....	8
Figure 1.2	$I_{OUT}$ vs. $V_{IN}$ with $R_S = 0.88\Omega$ .....	8
Figure 1.3	$I_{OUT}$ vs. $V_{OUT}$ with $R_S = 0.42\Omega$ .....	8
Figure 1.4	$I_{OUT}$ vs. $V_{OUT}$ with $R_S = 0.88\Omega$ .....	8
Figure 1.5	Efficiency vs. $V_{IN}$ with $R_S = 0.42\Omega$ .....	8
Figure 1.6	Efficiency vs. $V_{IN}$ with $R_S = 0.88\Omega$ .....	8
Figure 1.7	Efficiency vs. $V_{OUT}$ with $R_S = 0.42\Omega$ .....	9
Figure 1.8	Efficiency vs. $V_{OUT}$ with $R_S = 0.88\Omega$ .....	9
Figure 1.9	$V_{FB}$ Reverence Voltage vs. $V_{IN}$ .....	9
Figure 1.10	$I_{OUT}$ vs. PWM Duty Cycle.....	9
Figure 1.11	$V_{OUT}$ , $V_{IN}$ , and $I_{L1}$ during Soft Start.....	10
Figure 1.12	$V_{OUT}$ , $V_{LX}$ , and $I_{OUT}$ during Typical Operation.....	10
Figure 1.13	$V_{OUT}$ , $V_{LX}$ , and $I_{L1}$ when Over-Voltage Protection (OVP) Threshold is Exceeded.....	11
Figure 2.1	Typical Application Circuit.....	13
Figure 2.2	Example Circuit for Controlling Output Current via an External DC Control Voltage.....	13
Figure 2.3	Example Circuit for Controlling Output Current via a PWM Control Signal.....	14
Figure 2.4	Example Circuit for Constant Voltage Source Applications.....	16
Figure 6.1	ZLED7015 Pin Configuration—MSOP-10 Package.....	19
Figure 6.2	MSOP-10 Package Dimensions for the ZLED7015.....	20

## List of Tables

Table 1.1	Absolute Maximum Ratings.....	6
Table 1.2	Operating Conditions.....	6
Table 1.3	Electrical Parameters.....	7
Table 6.1	Pin Description MSOP-10.....	19

# ZLED7015

1.0MHz Boost Converter with Internal 35V Switch

**ZMDI**<sup>®</sup>

The Analog Mixed Signal Company



## 1 IC Characteristics

Note: Exceeding the maximum ratings given in this section could cause operation failure and/or cause permanent damage to the ZLED7015. Exposure to these conditions for extended periods may affect device reliability.

### 1.1 Absolute Maximum Ratings

Table 1.1 Absolute Maximum Ratings

No.	PARAMETER	SYMBOL	CONDITIONS	MIN	TYP	MAX	UNIT
1.1.1	Supply voltage on VDD pin (also see specification 1.2.2)	V <sub>DD</sub>		-0.3		40.0	V
1.1.2	LX pin output voltage	V <sub>LX</sub>		-0.3		40.0	V
1.1.3	All other pins			-0.3		6.0	V
1.1.4	ESD Performance Human Body Model		High voltage pins: 1, 4, 5, 9, and 10			±2.5	kV
			Low voltage pins: 2, 3, 6, 7, and 8			±4	kV
1.1.5	Junction temperature	T <sub>J</sub> MAX		-40		150	°C
1.1.6	Storage temperature	T <sub>ST</sub>		-65		150	°C
1.1.7	Lead soldering temperature		10 seconds maximum			260	°C
1.1.8	Junction-to-ambient thermal resistance	R <sub>θJA</sub>				60	°C/W

### 1.2 Operating Conditions

Table 1.2 Operating Conditions

No.	PARAMETER	SYMBOL	CONDITIONS	MIN	TYP	MAX	UNIT
1.2.1	Operating temperature	T <sub>OP</sub>		-40		+85	°C
1.2.2	Supply voltage on VDD pin (also see absolute maximum specification 1.1.1)	V <sub>DD</sub>		6		30	V

# ZLED7015

## 1.0MHz Boost Converter with Internal 35V Switch



### 1.3 Electrical Parameters

Test conditions for the following specifications are  $T_{amb} = 25^{\circ}\text{C}$  (typical) and  $V_{DD} = 12\text{V}$ , unless otherwise noted.

Production testing of the ZLED7015 is performed at  $25^{\circ}\text{C}$  unless otherwise stated. Functional operation of the ZLED7015 and specified parameters at other temperatures are guaranteed by design, characterization, and process control.

**Table 1.3** Electrical Parameters

No.	PARAMETER	SYMBOL	CONDITIONS	MIN	TYP	MAX	UNIT
1.3.1	Supply current	$I_{DD}$	Continuous switching		2		mA
			Quiescent: no switching		1.1		mA
1.3.2	Shutdown current	$I_{SD}$	Shutdown: no switching; $V_{EN}=0\text{V}$		15		$\mu\text{A}$
1.3.3	LX switching frequency	$f_{OCS}$			1		MHz
1.3.4	Maximum duty cycle	$D_{LX}$			90		%
1.3.5	EN pin ON threshold voltage	$V_{ENon}$	Rising $V_{EN}$	1.4			V
1.3.6	EN pin OFF threshold voltage	$V_{ENoff}$	Falling $V_{EN}$			0.4	V
1.3.7	Internal feedback reference voltage	$V_{FB}$		0.285	0.3	0.315	V
1.3.8	Integrated switch ON resistance	$R_{DSon}$			0.8	1.2	$\Omega$
1.3.9	Integrated switch current limit	$I_{SWlimit}$	Duty cycle = 90%	1.8	2.1	2.4	A
1.3.10	Integrated switch leakage current	$I_{SWleak}$	$V_{LX} = 40\text{V}$			1	$\mu\text{A}$
1.3.11	Internal regulator	$V_P$	$6\text{V} < V_{DD} < 30\text{V}$ , $C_{VP}=10\mu\text{F}$	4.5	5.0	5.5	V
1.3.12	Over-temperature protection (OTP) threshold	$T_{OTP}$			150		$^{\circ}\text{C}$
1.3.13	OTP threshold hysteresis	$T_{OTP\_HYS}$			50		$^{\circ}\text{C}$
1.3.14	Under-voltage lock-out threshold (UVLO)	$V_{UVLO}$	Falling $V_{DD}$		2.9		V
1.3.15	UVLO hysteresis	$V_{UVLO\_HYS}$			100		mV
1.3.16	Internal over-voltage threshold reference voltage	$V_{OVP\_TH}$			0.9		V
1.3.17	Over-voltage protection threshold hysteresis	$V_{OVP\_TH\_HYS}$			10		mV

# ZLED7015

## 1.0MHz Boost Converter with Internal 35V Switch



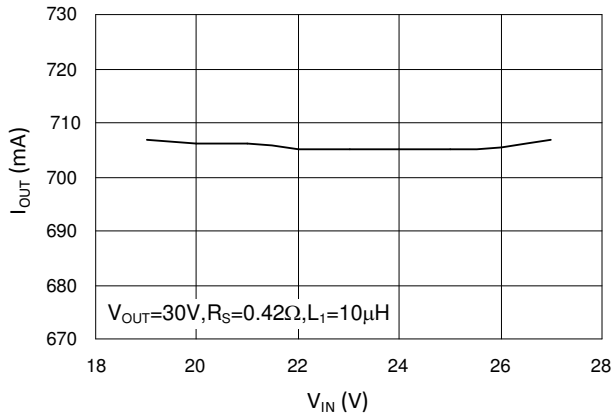
The Analog Mixed Signal Company



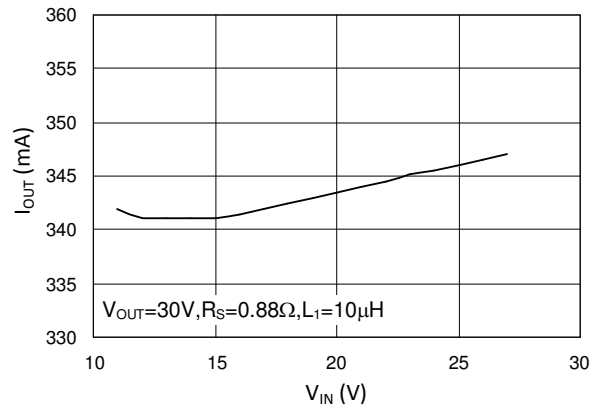
### 1.4 Typical Operating Characteristics

The curves are valid for the typical application circuit and  $T_{amb} = 25^{\circ}\text{C}$  unless otherwise noted.

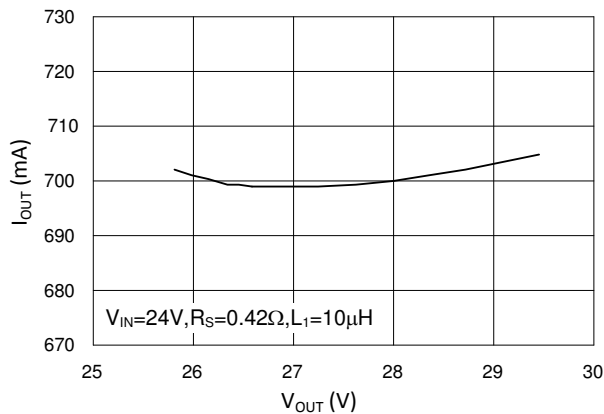
**Figure 1.1**  $I_{OUT}$  vs.  $V_{IN}$  with  $R_S = 0.42\Omega$



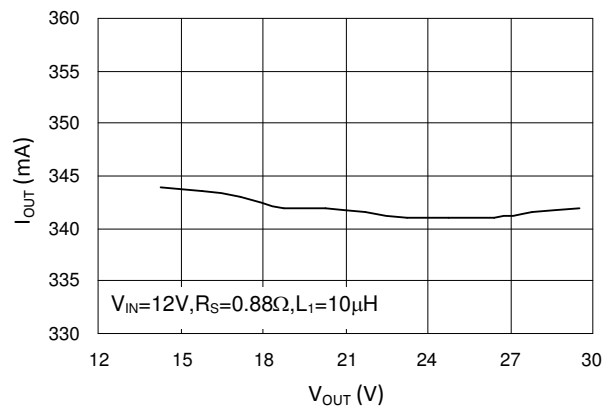
**Figure 1.2**  $I_{OUT}$  vs.  $V_{IN}$  with  $R_S = 0.88\Omega$



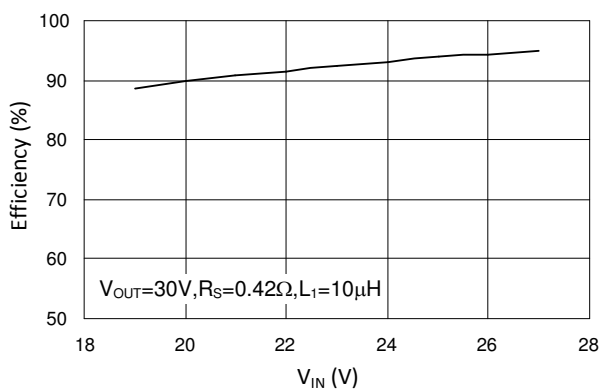
**Figure 1.3**  $I_{OUT}$  vs.  $V_{OUT}$  with  $R_S = 0.42\Omega$



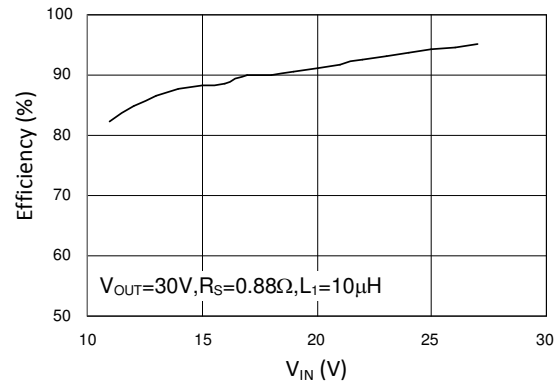
**Figure 1.4**  $I_{OUT}$  vs.  $V_{OUT}$  with  $R_S = 0.88\Omega$



**Figure 1.5** Efficiency vs.  $V_{IN}$  with  $R_S = 0.42\Omega$



**Figure 1.6** Efficiency vs.  $V_{IN}$  with  $R_S = 0.88\Omega$



# ZLED7015

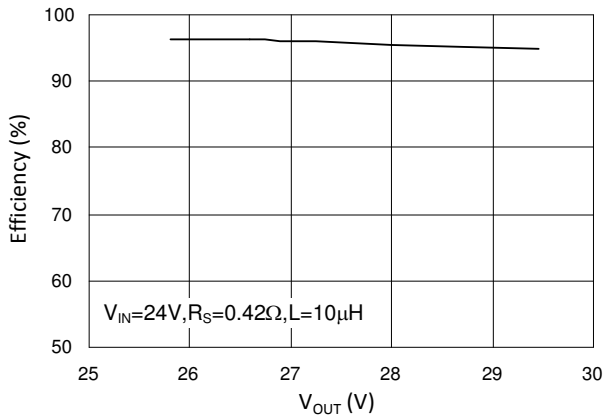
1.0MHz Boost Converter with Internal 35V Switch



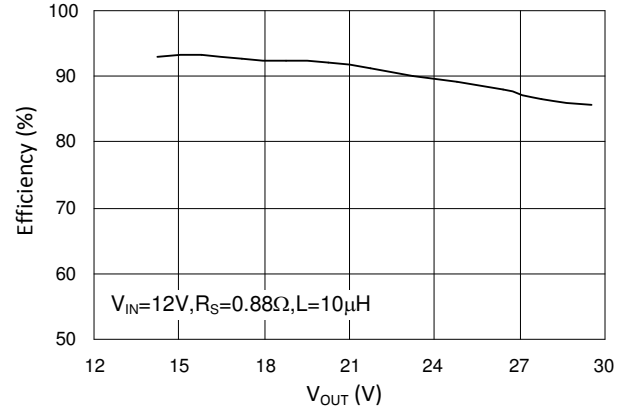
The Analog Mixed Signal Company



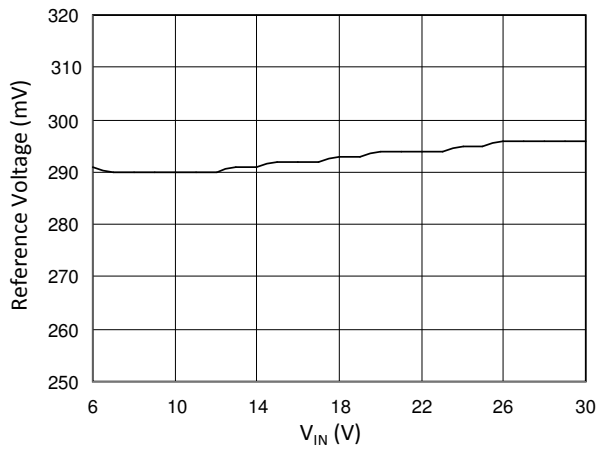
**Figure 1.7 Efficiency vs.  $V_{OUT}$  with  $R_S = 0.42\Omega$**



**Figure 1.8 Efficiency vs.  $V_{OUT}$  with  $R_S = 0.88\Omega$**

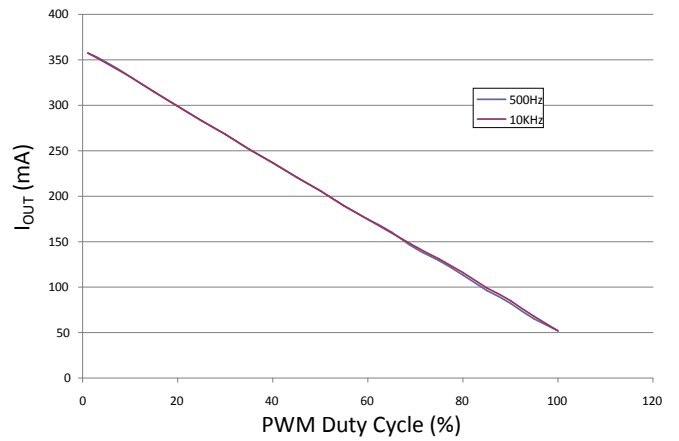


**Figure 1.9  $V_{FB}$  Reverence Voltage vs.  $V_{IN}$**



**Figure 1.10  $I_{OUT}$  vs. PWM Duty Cycle**

(For details of PWM dimming, see section 2.2.3.)



# ZLED7015

1.0MHz Boost Converter with Internal 35V Switch



The Analog Mixed Signal Company



## 1.5 Characteristic Waveforms

Figure 1.11  $V_{OUT}$ ,  $V_{IN}$ , and  $I_{L1}$  during Soft Start

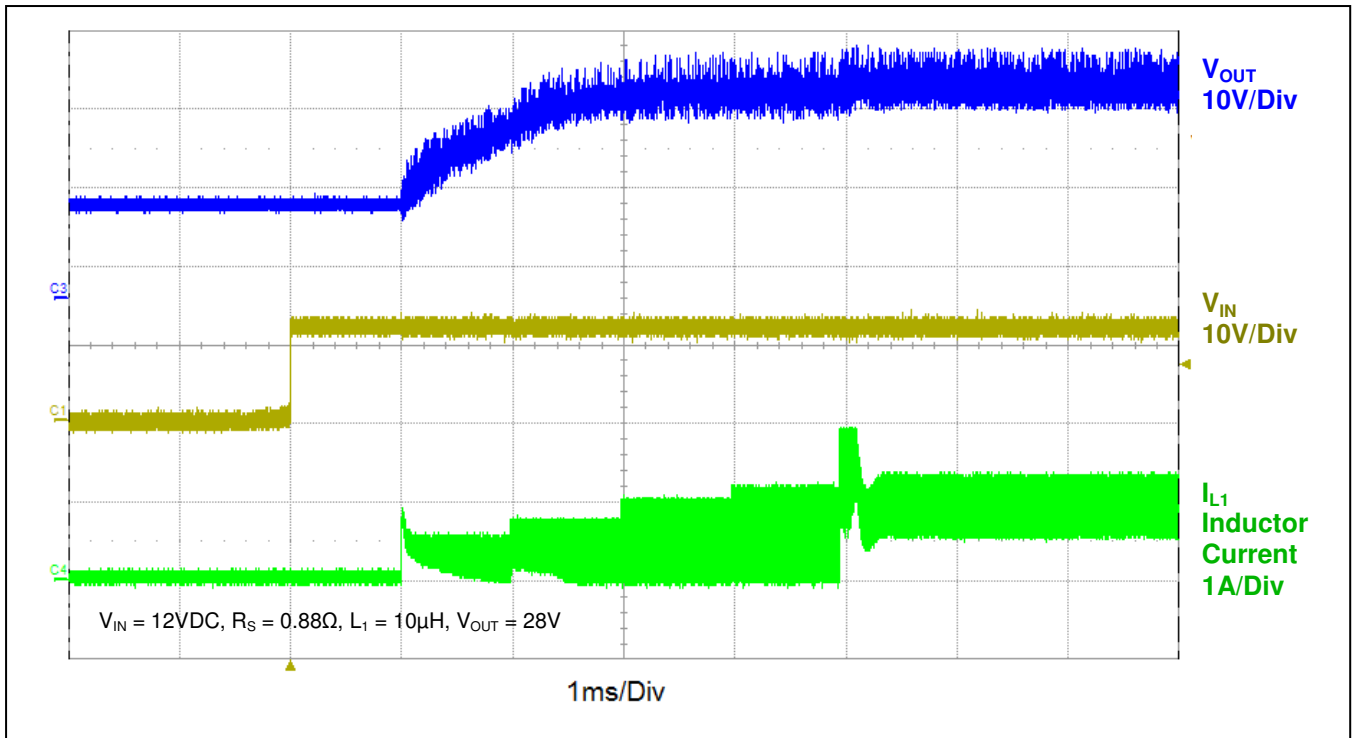
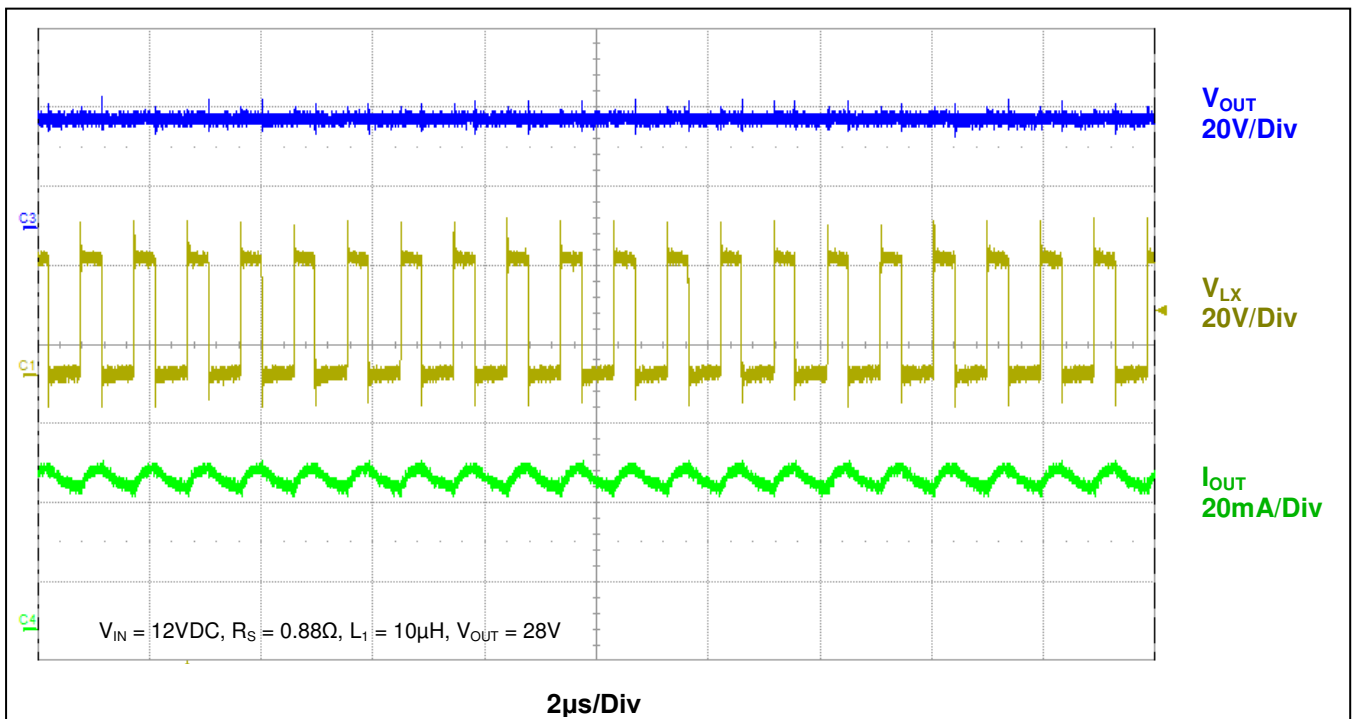


Figure 1.12  $V_{OUT}$ ,  $V_{LX}$ , and  $I_{OUT}$  during Typical Operation

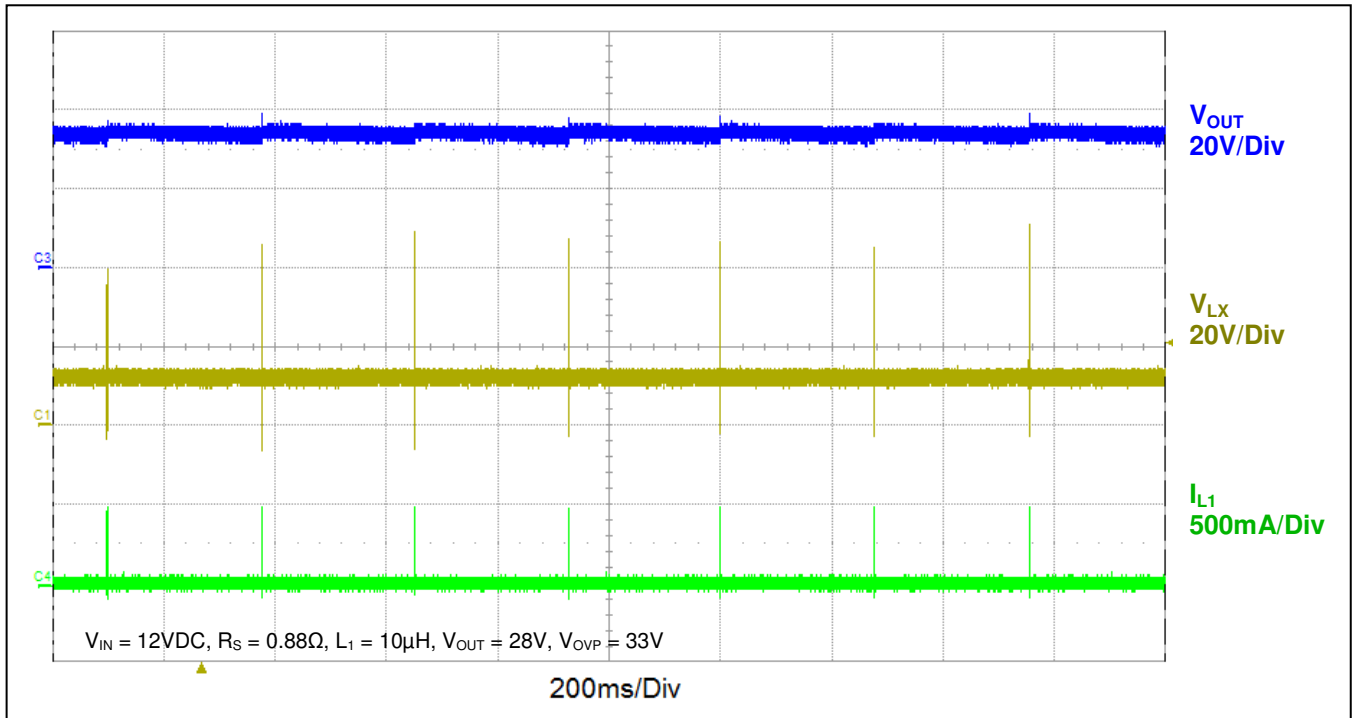


# ZLED7015

1.0MHz Boost Converter with Internal 35V Switch



Figure 1.13  $V_{OUT}$ ,  $V_{LX}$ , and  $I_{L1}$  when Over-Voltage Protection (OVP) Threshold is Exceeded





## 2 Circuit Description

The ZLED7015 is a constant-current boost converter that can also function as a constant voltage driver for LED applications. The boost converter topology features an internal 35V power switch and feedback circuit to control the output to the LED string. Optimal performance is achieved by operating in continuous conduction mode within the application's load current range; i.e., the current through inductor L1 is always above 0A. The output current is set by an external resistor and the device supports DC linear or PWM dimming. Additional device features include selectable open-load/over-voltage protection, over-temperature protection, under-voltage lockout, and an automatic soft-start function to minimize the inrush current during startup.

### 2.1 EN Pin, VP Pin, and Soft-Start Function

The EN pin can be used to enable or disable the ZLED7015. When the voltage on the EN pin rises above the ON threshold voltage  $V_{ENon}$  specified in Table 1.3, the ZLED7015 begins its "soft-start." When the voltage at EN falls below the OFF threshold voltage  $V_{ENoff}$ , the ZLED7015 shuts down. There is a hysteresis between  $V_{ENon}$  and  $V_{ENoff}$  to prevent intermittent operation.

The ZLED7015's internal "soft-start" function ensures a smooth device start-up by preventing excessive inrush current and providing a controlled rise in the output current. When the soft-start function is initiated, the internal circuitry clamps the internal switch current threshold to zero during a 1millisecond delay. The soft-start function then gradually increases the internal switch current threshold over a 4-5 msec period. See Figure 1.11 for an illustration of typical waveforms during start-up.

**Important:** The EN pin requires termination. If the EN pin is not used to control operation, connect it to the positive power supply through a 100kΩ resistor. Do not allow the EN pin to float.

The VP pin is connected to the ZLED7015's internal power regulator and requires an external bypass capacitor,  $C_{VP}$ , to ensure correct device operation.

### 2.2 Output Current Control

The LED current is determined by the voltage across the external sense resistor  $R_S$ , which is fed back to the input FB. Internally, this is compared with the internal feedback reference voltage,  $V_{FB}$  (see typical application shown on page 2), and the duty cycle of the internal power switch is adjusted to reduce or increase the output current  $I_{OUT}$ . Selection of  $R_S$  is discussed in section 2.2.1, and other external components are discussed in section 3. Dimming can be controlled by superimposing a DC or filtered pulse-width modulated (PWM) signal on the feedback voltage from  $R_S$ . Refer to sections 2.2.2 and 2.2.3, respectively, for more details.

#### 2.2.1 Output Current and $R_S$

The ZLED7015 continually adjusts the output current,  $I_{OUT}$ , in order to maintain the voltage level at the FB pin equal to the internal feedback reference voltage,  $V_{FB}$ . Equation (1) shows the basic relationship between  $I_{OUT}$ ,  $V_{FB}$ , and  $R_S$  for the basic application shown in Figure 2.1.

$$I_{OUT} = \frac{V_{FB}}{R_S} = \frac{0.3V}{R_S} \quad (1)$$

Where

$I_{OUT}$  = Average output current through the LED(s) in amperes

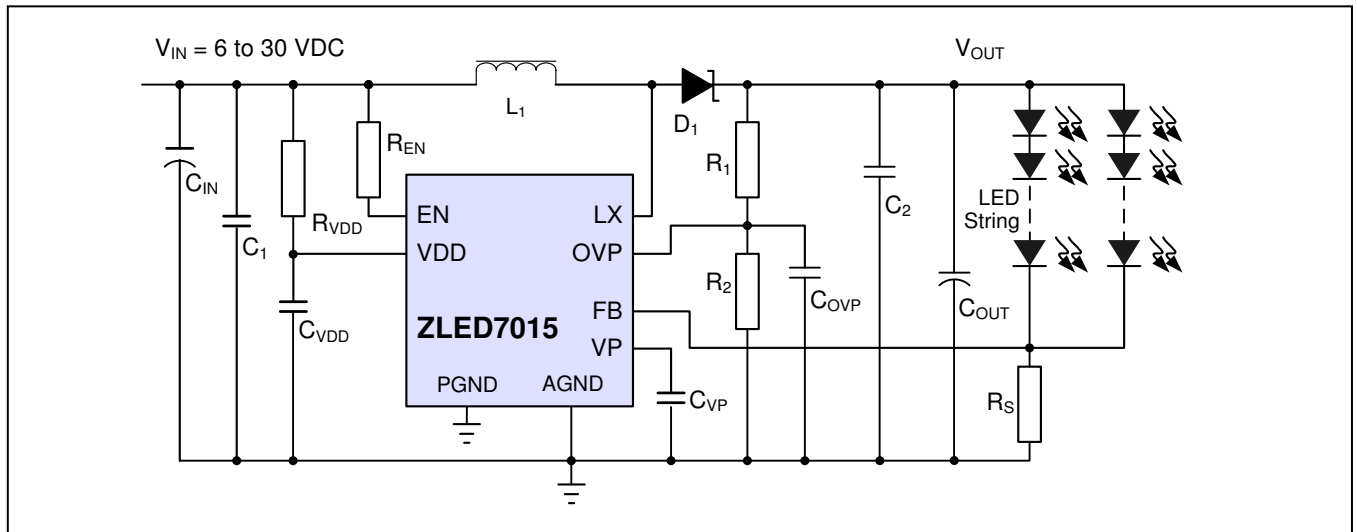
$V_{FB}$  = Internal feedback reference voltage (see Table 1.3, parameter 1.3.7)

# ZLED7015

## 1.0MHz Boost Converter with Internal 35V Switch



Figure 2.1 Typical Application Circuit

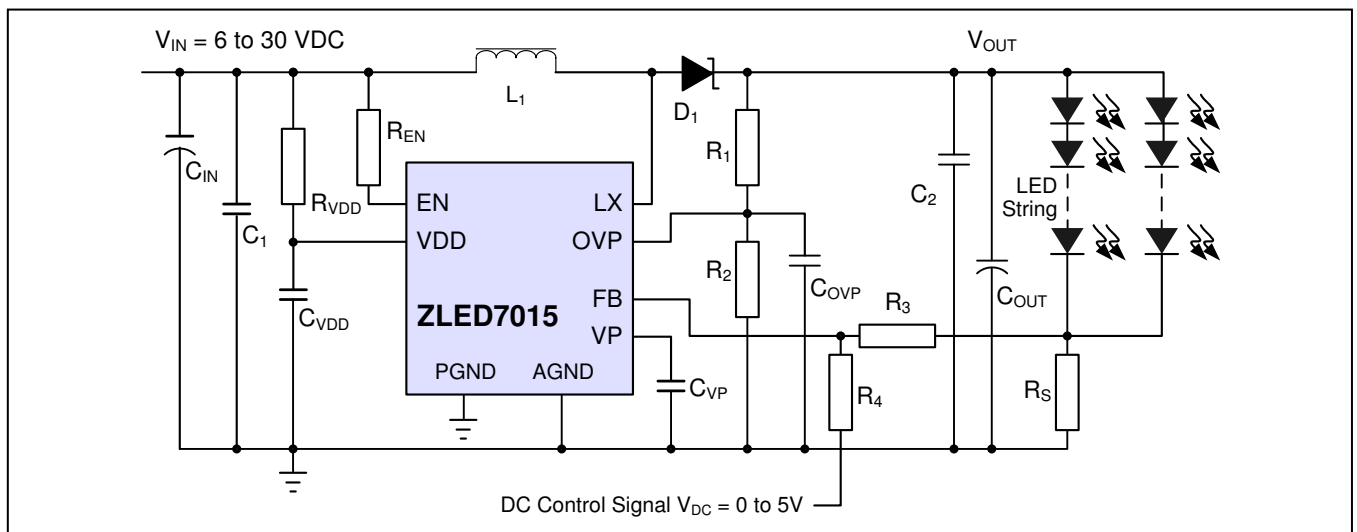


### 2.2.2 Dimming via External DC Voltage Control

The LED output current can be set below the nominal average value defined on section 2.2.1 by using an external DC voltage control signal superimposed on the FB pin as shown in the example circuit in Figure 2.2. As the DC control signal,  $V_{DC}$ , increases, the current through  $R_3$  increases with a subsequent increase in the voltage at the FB pin. This causes the ZLED7015 to compensate by reducing the output current through the LED string. Consequently, the output current is inversely proportional to the DC control voltage.

**Note:** It is important to ensure that the LED output voltage  $V_{OUT}$  remains higher than the input voltage  $V_{IN}$  in dimming applications.

Figure 2.2 Example Circuit for Controlling Output Current via an External DC Control Voltage





The output current controlled by the DC voltage on FB can be calculated using equation (2):

$$I_{OUT} = \frac{V_{FB} - \left( \frac{R_3 \times (V_{DC} - V_{FB})}{R_4} \right)}{R_S} \quad (2)$$

Where

$I_{OUT}$  = Output current through the LED(s) with a DC control voltage

$V_{FB}$  = Internal feedback reference voltage (Table 1.3, parameter 1.3.7)

$V_{DC}$  = External DC control voltage

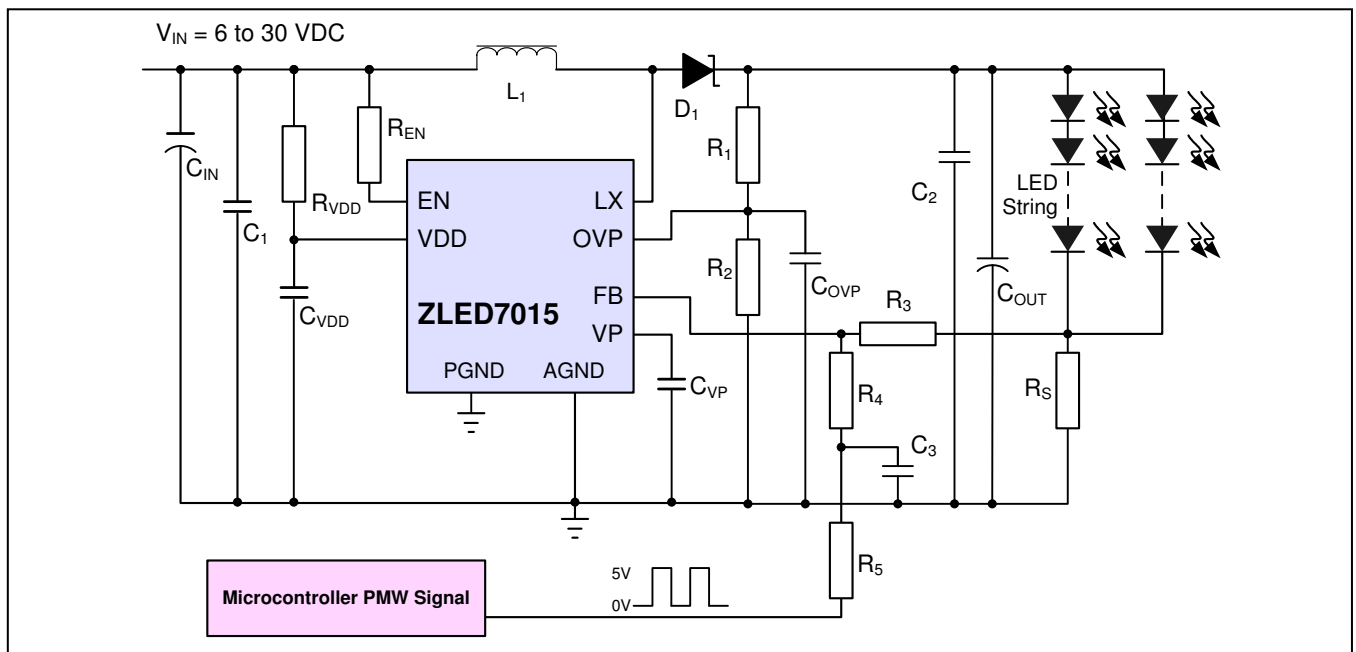
### 2.2.3 Dimming via PWM Control

An external pulse-width modulated (PWM) signal input can be used to control the LED output current by driving the output current to a value below the nominal average value defined in section 2.2.1. A microcontroller can be used to generate the PWM signal. See Figure 2.3 for an example circuit. The PWM signal is superimposed on the feedback voltage from  $R_S$  at the FB pin via the input filter  $R_5/C_3$  and  $R_4$ , which produces a DC voltage with a ripple. This method of controlling dimming is similar to the external DC voltage control described in section 2.2.2. The duty cycle of the PWM signal regulates the filtered DC voltage level, which inversely controls the LED output current level. When the duty cycle is at 100%, the output current is at the minimum. With a 0% duty cycle, the output current is at the maximum.

Recommendation: With a PWM signal of 0 to 5V, use an  $R_3$  value of 10k $\Omega$  and a PWM frequency of >2kHz to minimize the filtered PWM voltage ripple.

**Note:** It is important to ensure that the LED output voltage  $V_{OUT}$  remains higher than the input voltage  $V_{IN}$  in dimming applications.

**Figure 2.3 Example Circuit for Controlling Output Current via a PWM Control Signal**





The output current controlled by the PWM voltage on FB can be calculated using equation (3):

$$I_{OUT} = \frac{V_{FB} - \left( \frac{R_3 \times (V_{PWM} \times D_{PWM} - V_{FB})}{R_4 + R_5} \right)}{R_s} \quad (3)$$

Where

$I_{OUT}$  = Output current through the LED(s) with a PWM control voltage

$V_{FB}$  = Internal feedback reference voltage (see Table 1.3, parameter 1.3.7)

$V_{PWM}$  = External PWM control voltage

$D_{PWM}$  = Duty cycle of the PWM control signal

### 2.2.4 Microcontroller LED Control

A microcontroller can control the LED output current by providing a PWM control signal to the FB pin as described in section 2.2.3.

Depending on the application, the microcontroller can also be used to control the shutdown circuitry via the EN pin (see section 2.1) providing a fast and smooth transition to shutdown.

### 2.2.5 Constant Voltage Application

In addition to functioning as a constant-current boost converter for driving an LED string, the ZLED7015 can be configured as a constant-voltage boost converter for other applications. Figure 2.4 demonstrates a typical circuit for this application.

The output voltage controlled by the values of  $R_3$  and  $R_5$  can be calculated using equation (4):

$$V_{OUT} = V_{FB} \times \frac{(R_3 + R_5)}{R_s} \quad (4)$$

Where

$V_{OUT}$  = Output voltage to the load

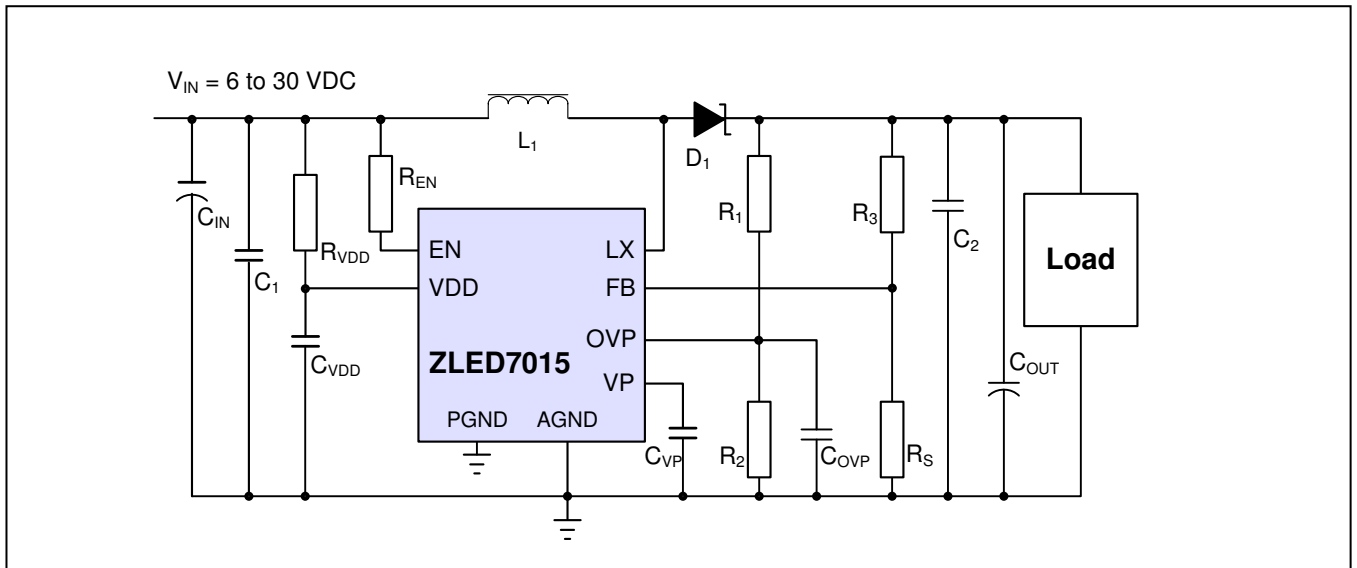
$V_{FB}$  = Internal feedback reference voltage (Table 1.3, parameter 1.3.7)

# ZLED7015

1.0MHz Boost Converter with Internal 35V Switch



**Figure 2.4** Example Circuit for Constant Voltage Source Applications





### 3 Application Circuit Design

The following sections cover selection of the external components shown in the typical application on page 2.

#### 3.1 External Component – $R_S$

Recommendation: Use precision resistors ( $\pm 1\%$  or better tolerance) for the  $R_S$  resistor to ensure accurate control of the LED current.

See section 2.2.1 for the equation for selecting the value of  $R_S$ , which sets the nominal current output.

#### 3.2 External Component – Inductor $L_1$

Designing the circuit so that the current through inductor  $L_1$  is always above 0V (i.e., continuous mode) typically gives the best performance due to improved load regulation and reduced output ripple. Select an inductor that has a saturation current and a current rating greater than the mean input current.

The inductor value selection requires trade-offs between unwanted ripple current and parasitic effects. A larger value inductor reduces inductor ripple current, resulting in less output ripple voltage; however, higher values also increase parasitic resistance, which can degrade performance. For most applications, a  $10\mu\text{H}$  inductor with a saturation current  $>2.5\text{A}$  is adequate. See section 7.4 for layout restrictions.

#### 3.3 External Components – Input Decoupling Capacitors $C_1$ and $C_{IN}$

The input capacitors  $C_1$  and  $C_{IN}$  minimize the input voltage noise and ripple. Recommendation: use a  $22\mu\text{F}$  or larger low-ESR electrolytic capacitor for  $C_{IN}$  in parallel with a  $1\mu\text{F}$  ceramic capacitor rated at greater than the input voltage plus a safety margin for  $C_1$ .

#### 3.4 External Component – Output Capacitors $C_2$ and $C_{OUT}$

The output capacitors  $C_2$  and  $C_{OUT}$  minimize the output voltage ripple. Recommendation: use a  $22\mu\text{F}$  or larger low-ESR electrolytic capacitor for  $C_{OUT}$  in parallel with a  $1\mu\text{F}$  ceramic capacitor rated at greater than the output voltage plus a safety margin for  $C_2$ .

#### 3.5 External Component – Diode $D_1$

For the diode  $D_1$ , select a high-speed, low-capacitance Schottky diode with low reverse leakage at the maximum operating voltage and temperature to ensure maximum efficiency and performance.

Important: Choose diodes with a continuous current rating higher than the maximum output load current and a peak current rating above the peak coil current. When operating above  $85^\circ\text{C}$ , the reverse leakage of the diode must be addressed because it can cause excessive power dissipation in the diode, especially when the output voltage is relatively high. Its reverse breakdown voltage must be greater than the over-voltage protection level  $V_{OVP}$  (see section 4.2).

Note: Silicon diodes have higher forward voltage and higher voltage overshoot before they start conducting, which can increase the peak voltage on the LX output. Ensure that the total voltage appearing on the LX pin, including supply ripple, is within the specified range (see Table 1.1).

#### 3.6 Additional External Components

For the VDD input, connect resistor  $R_{VDD}$  to the positive power supply and connect ceramic capacitor  $C_{VDD}$  to ground. Recommendations: use  $1\mu\text{F}$  for  $C_{VDD}$ ; use  $300\Omega$  for  $R_{VDD}$  with input voltages  $\geq 8\text{V}$ , use  $50\Omega$  for  $R_{VDD}$  with input voltages  $< 8\text{V}$ .

For the VP pin, connect a  $10\mu\text{F}$  ceramic bypass capacitor to ground ( $C_{VP}$ ).

If the EN pin is not used, connect a  $100\text{k}\Omega$  resistor to the positive power supply ( $R_{EN}$ ). Do not allow the EN pin to float.



## 4 Operating Conditions

### 4.1 Under-Voltage Lockout

The under-voltage lockout (UVLO) monitors the ZLED7015's internal regulator output voltage,  $V_P$ , to ensure correct operation of the internal circuitry. When the  $V_P$  voltage is lower than the UVLO threshold  $V_{UVLO}$ , the ZLED7015 disables the internal power switch. If the  $V_P$  voltage reaches a level higher than the UVLO threshold plus UVLO hysteresis ( $V_{UVLO} + V_{UVLO\_HYS}$ ) the UVLO turns off and the internal power switch is re-enabled. See parameters 1.3.14 and 1.3.15 in section 1.3 for the UVLO threshold and hysteresis.

### 4.2 Over-Voltage Threshold and Open-Circuit Protection

If the LED string becomes open or the FB pin is shorted to ground, the ZLED7015 would normally continually boost the output voltage to potentially damaging levels. To prevent this, the ZLED7015 includes an integrated over-voltage protection (OVP) mechanism. If the output voltage reaches the ZLED7015's OVP threshold  $V_{OVP}$ , the protection circuitry is triggered and the device automatically turns off the internal switch, stopping the boost function and protecting the device. Once the output voltage falls below the OVP threshold minus OVP threshold hysteresis ( $V_{OVP\_TH} - V_{OVP\_TH\_HYS}$ ), the device will enter soft-start mode.

The OVP threshold  $V_{OVP}$  for the ZLED7015 is selectable via the  $R_1$  and  $R_2$  resistor values determined by equation (5):

$$V_{OVP} = V_{OVP\_TH} \times \frac{(R_1 + R_2)}{R_2} \quad (5)$$

Where

$V_{OVP}$  = Over-voltage protection threshold

$V_{OVP\_TH}$  = Internal over-voltage threshold reference voltage (see Table 1.3, parameter 1.3.16)

**Important:** Care must be taken to select proper  $R_1$  and  $R_2$  values to ensure proper functioning of the ZLED7015. See specification 1.3.16 in Table 1.3 for the over-voltage protection threshold voltage. Set  $V_{OVP}$  3V higher than the normal operation output voltage.

**Important:** When setting  $V_{OVP}$ , care must be taken to ensure  $V_{OUT}$  cannot exceed 35V.

Minimize noise coupling on the OVP pin, which could interfere with proper protection, by connecting a 10nF ceramic capacitor to GND from OVP ( $C_{OVP}$ ).

### 4.3 Over-Temperature Protection

The ZLED7015 features on-chip over-temperature protection. If its internal temperature exceeds the over-temperature protection (OTP) threshold,  $T_{OTP}$ , due to high power dissipation and improper heat sinking, the internal power switch is disabled. Once the internal temperature has fallen below the OTP threshold minus the OTP threshold hysteresis ( $T_{OTP} - T_{OTP\_HYS}$ ), the ZLED7015 enters the soft-start mode (see section 2.1).

Refer to Table 1.1 for the maximum package power dissipation specifications for the ZLED7015's MSOP-10 package.



### 5 ESD/Latch-Up-Protection

All high voltage pins (1, 4, 5, 9, and 10) have an ESD protection of  $\geq \pm 2500V$  according to the Human Body Model (HBM). The ESD test follows the Human Body Model based on MIL 883-H, Method 3015.8

All low voltage pins (2, 3, 6, 7, and 8) have an ESD protection of  $\geq \pm 4000V$  according to the Human Body Model (HBM). The ESD test follows the Human Body Model based on MIL 883-H, Method 3015.8

All pins pass the latch-up test based on the JEDEC Standard No. 78B, December 2008.

### 6 Pin Configuration and Package

The ZLED7015 package is an MSOP-10, which has a thermal resistance (junction to ambient) of  $R_{\theta JA} = 60^{\circ}C/W$ .

Figure 6.1 ZLED7015 Pin Configuration—MSOP-10 Package

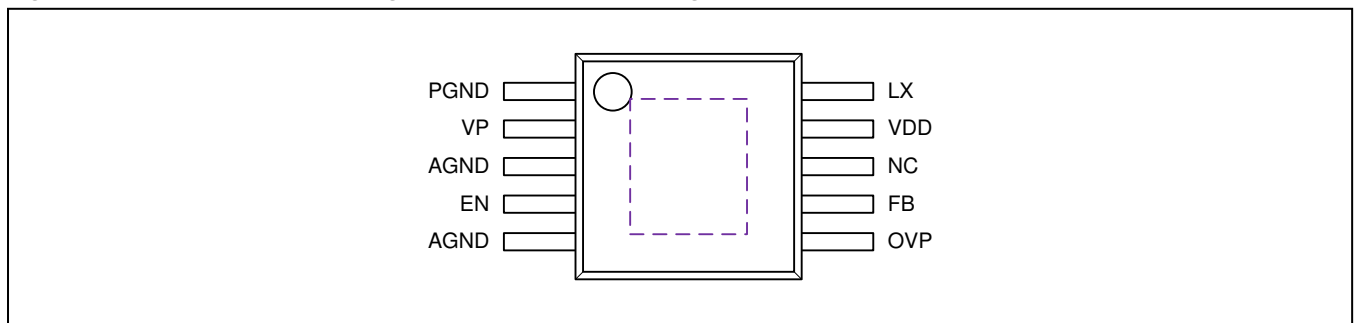


Table 6.1 Pin Description MSOP-10

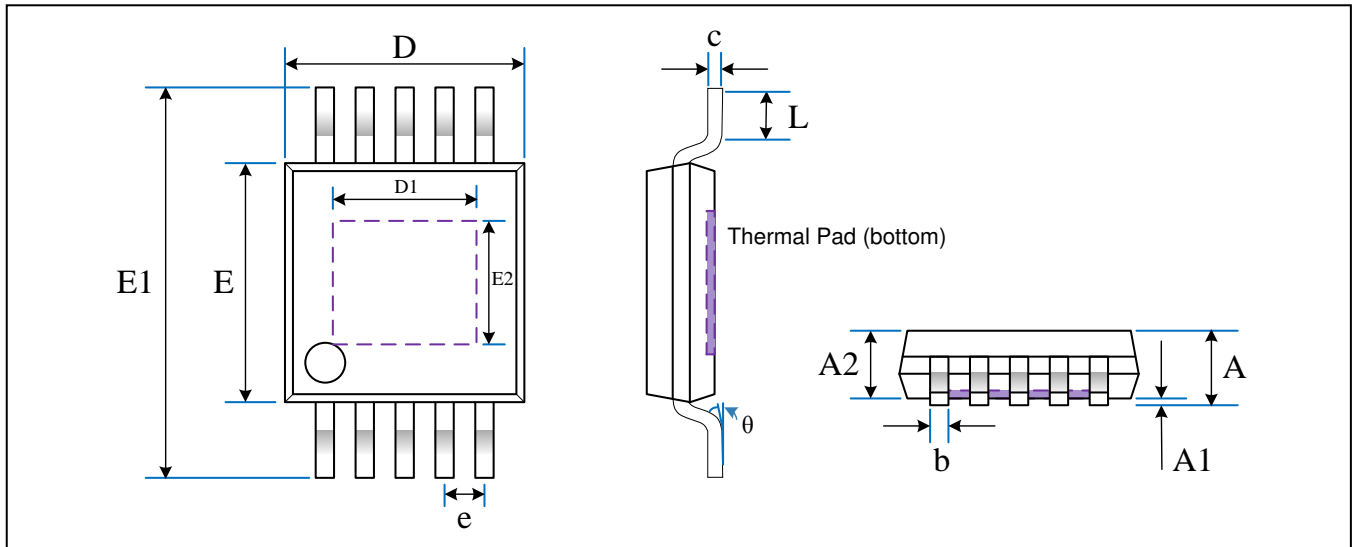
Pin Name	No.	Description
PGND	1	Power ground
VP	2	Internal 5V linear regulator output. VP is the power supply for the internal switch gate driver and the internal control circuitry. Use a 10 $\mu$ F ceramic bypass capacitor between VP and ground.
AGND	3	Analog (signal) ground.
EN	4	Enable control input. Important: Do not allow this pin to float.
AGND	5	Analog (signal) ground.
OVP	6	Over-voltage protection control input.
FB	7	Feedback voltage input. The nominal average output current is set by the value of $R_S$ connected from FB to GND – see section 2.2.1 for details. Important: Do not allow the FB pin to float.
n.c.	8	No connection
VDD	9	Supply voltage (6V to 30V)—see section 7 for layout considerations.
LX	10	Drain of the internal switch. Connect the power inductor between LX and the power supply. Connect the output rectifier $D_1$ between LX and the output circuit. See section 1.1 for output range specifications.
Thermal Pad		Connect to ground.

# ZLED7015

1.0MHz Boost Converter with Internal 35V Switch



Figure 6.2 MSOP-10 Package Dimensions for the ZLED7015



Symbol	Dimension (mm, except $\theta$ )		Symbol	Dimension (mm)	
	Min	Max		Min	Max
A	0.82	1.10	D	2.90	3.10
A1	0.02	0.15	D1	1.70	1.90
A2	0.75	0.95	e	0.50 BSC	
b	0.18	0.28	E	2.90	3.10
c	0.09	0.23	E1	4.75	5.05
			E2	1.45	1.65
$\theta$	0°	6°	L	0.40	0.80



## 7 Layout Requirements

Follow these layout guidelines to avoid circuit instability and EMI vulnerability, especially with high current or high switching frequency applications.

Important: Route traces connecting the feedback network to the FB and OVP pin away from the  $L_1$  inductor, the  $D_1$  Schottky diode, and the LX pin. These traces should be as short as possible. Shield the FB pin and feedback network with a ground plane or trace to prevent noise coupling.

### 7.1 General Considerations and Ground Traces

Make the ground traces as wide and short as possible. To prevent a signal ground shift, keep traces for the signal ground (pin 5) separate from traces for the power ground (pin 1). Connect the signal and power ground traces together at either the large ground plane or the negative terminal of  $C_{IN}$ .

Connect the grounds for other components to the signal ground.

Use wide traces for connection of the high current loop.

### 7.2 Layout Considerations for $C_1$ , $C_{IN}$ , $C_2$ and $C_{OUT}$

Place  $C_1$ ,  $C_2$  and  $C_{OUT}$  as close as possible to the ZLED7015 to minimize ripple. The  $C_{IN}$  input decoupling capacitor must be placed as close as possible to the VDD pin to minimize power supply noise, which can reduce efficiency.

### 7.3 Layout Considerations for the EN Pin

Important: Do not allow the EN pin to float. It must be terminated if it is not used.

### 7.4 Layout Considerations for the LX Pin, $L_1$ External Coil, and $D_1$ Diode

Minimize the length of circuit board traces connected to the LX pin because it is a fast switching output.

Place  $L_1$  and  $D_1$  as close as possible to the LX pin using traces that are as short and wide as possible. Avoid routing other traces crossing or in parallel with this node to minimize the noise coupling into this circuit.

### 7.5 Layout Considerations for the External Current Sense Resistor ( $R_S$ )

Any trace resistance in series with  $R_S$  must be taken into consideration when selecting its value. For the most accurate LED current control, use a trace that is as wide and short as possible for the  $R_S$  connection to ground. Connect it to the signal ground (pin 5), not the power ground (pin 1).

### 7.6 Layout Considerations for $C_{VP}$ and $C_{VDD}$

For good filtering, connect  $C_{VP}$  as close as possible to the VP pin and place  $C_{VDD}$  as close as possible to the VDD pin.

### 7.7 Layout Considerations for the Thermal Pad

To optimize heat dissipation, solder the thermal pad on the back of the MSOP-10 package to the large ground plan.

# ZLED7015

1.0MHz Boost Converter with Internal 35V Switch



The Analog Mixed Signal Company



## 8 Glossary of Terms

Term	Definition
LDO	Low Dropout Regulator
OTP	Over-Temperature Protection
OVP	Over-Voltage Protection
UVL	Under-Voltage Lockout

## 9 Ordering Information

Product Sales Code	Description	Package
ZLED7015-ZI1R	ZLED7015 – 1MHz Boost Converter with Internal 35V Switch	MSOP-10 (Tape & Reel)
ZLED7015KIT-E1	ZLED7015-E1 Evaluation Board, 1 ZLED-PCB10, and 5 ZLED7015 ICs	Kit

## 10 Document Revision History

Revision	Date	Description
1.00	December 20, 2011	First Issue.

Sales and Further Information					<a href="http://www.zmdi.com">www.zmdi.com</a>	<a href="mailto:LED_Drivers@zmdi.com">LED_Drivers@zmdi.com</a>
<b>Zentrum Mikroelektronik Dresden AG</b> Grenzstrasse 28 01109 Dresden Germany  Phone +49.351.8822.7.533 Fax +49.351.8822.8.7533	<b>ZMD America, Inc.</b> 275 South 5th Avenue Pocatello, ID 83201 USA  Phone +1.208.478.7200 Fax +1.208.478.7200	<b>Zentrum Mikroelektronik Dresden AG, Japan Office</b> 2nd Floor, Shinbashi Tokyu Bldg. 4-21-3, Shinbashi, Minato-ku Tokyo, 105-0004 Japan  Phone +81.3.6895.7410 Fax +81.3.6895.7301	<b>ZMD FAR EAST, Ltd.</b> 3F, No. 51, Sec. 2, Keelung Road 11052 Taipei Taiwan  Phone +886.2.2377.8189 Fax +886.2.2377.8199	<b>Zentrum Mikroelektronik Dresden AG, Korean Office</b> POSCO Centre Building West Tower, 11th Floor 892 Daechi, 4-Dong, Kangnam-Gu Seoul, 135-777 Korea  Phone +82.2.559.0660 Fax +82.2.559.0700		
<b>DISCLAIMER:</b> This information applies to a product under development. Its characteristics and specifications are subject to change without notice. Zentrum Mikroelektronik Dresden AG (ZMD AG) assumes no obligation regarding future manufacture unless otherwise agreed to in writing. The information furnished hereby is believed to be true and accurate. However, under no circumstances shall ZMD AG be liable to any customer, licensee, or any other third party for any special, indirect, incidental, or consequential damages of any kind or nature whatsoever arising out of or in any way related to the furnishing, performance, or use of this technical data. ZMD AG hereby expressly disclaims any liability of ZMD AG to any customer, licensee or any other third party, and any such customer, licensee and any other third party hereby waives any liability of ZMD AG for any damages in connection with or arising out of the furnishing, performance or use of this technical data, whether based on contract, warranty, tort (including negligence), strict liability, or otherwise.						

<b>Data Sheet</b> December 20, 2011	© 2011 Zentrum Mikroelektronik Dresden AG — Rev. 1.00 All rights reserved. The material contained herein may not be reproduced, adapted, merged, translated, stored, or used without the prior written consent of the copyright owner. The information furnished in this publication is subject to changes without notice.	22 of 22
--	---	----------