

Data Sheet

Rev. 1.20 / June 2013

ZSSC3154

Automotive Sensor Signal Conditioner with Dual Analog Output



Automotive ICs



Adaptable and Rugged

ZSSC3154

Automotive Sensor Signal Conditioner with Dual Analog Output

ZMDI[®]

The Analog Mixed Signal Company



Brief Description

The ZSSC3154 is an integrated circuit for highly accurate amplification and sensor-specific correction of a bridge sensor signal. Up to two temperature sensors can also be read in parallel.

The circuitry provides different configurations of the analog outputs to show two measurement results simultaneously. This also allows generating a complementary bridge sensor signal, which is often a requirement in safety-relevant applications.

The ZSSC3154 can measure and process two external temperature sensors to compensate the temperature drift of the bridge sensor signal and to output a separate temperature signal.

An integrated calibration microcontroller with an on-chip EEPROM performs the digital compensation of the sensor offset, the sensitivity, the temperature drift, and the nonlinearity of a sensor signal.

The one-pass digital end-of-line calibration combined with the integrated broken-chip detection supports automatic and highly efficient mass production.

Features

- Differential bridge sensor input
- Half-bridge sensor or temperature sensor input
- Digital compensation of offset, gain, nonlinearity, and temperature dependency
- Two analog outputs; behavior programmable by EEPROM configuration
- Sequential analog output mode provides two measurement values at one output pin
- On-chip diagnostic and safety features including sensor connection diagnostic and broken-chip detection
- 2 EEPROM words for arbitrary user data
- Multiple configurable output options

Benefits

- Bridge sensor signal validation for safety applications via two antivalent analog outputs or via half-bridge sensor measurement output
- Simultaneous measurement of sensor signals, including temperature signal for compensation and for temperature output
- Efficient use of non-calibrated elements for bridge sensors and temperature sensors without external trimming components
- Single-pass end-of-line calibration algorithm minimizes production costs
- Excellent EMC/ESD robustness and AEC-Q100 qualification

Available Support

- Evaluation Kit
- Application Notes
- Calculation Tools

Physical Characteristics

- Supply voltage: 4.5 to 5.5V
- Maximum supply voltage: 7.7V
- Input span: 1.8 to 267mV/V
- ADC resolution: 14 bit
- Output resolution: > 12 bit from 10% to 90%
- Operating temperature range: -40 °C to 125 °C
- Package: QFN32 5x5mm or die

ZSSC3154 Basic Circuit

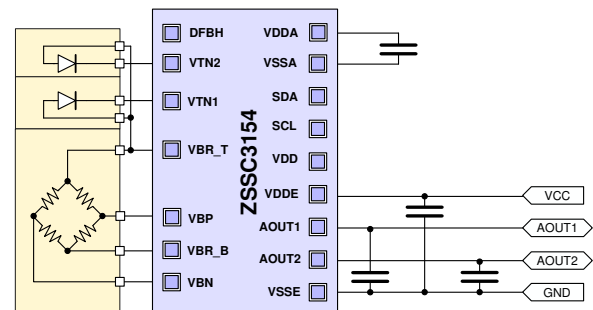

For more information, contact ZMDI via SSC@zmdi.com.

ZSSC3154

Automotive Sensor Signal Conditioner with Dual Analog Output



The Analog Mixed Signal Company



ZSSC3154 Block Diagram

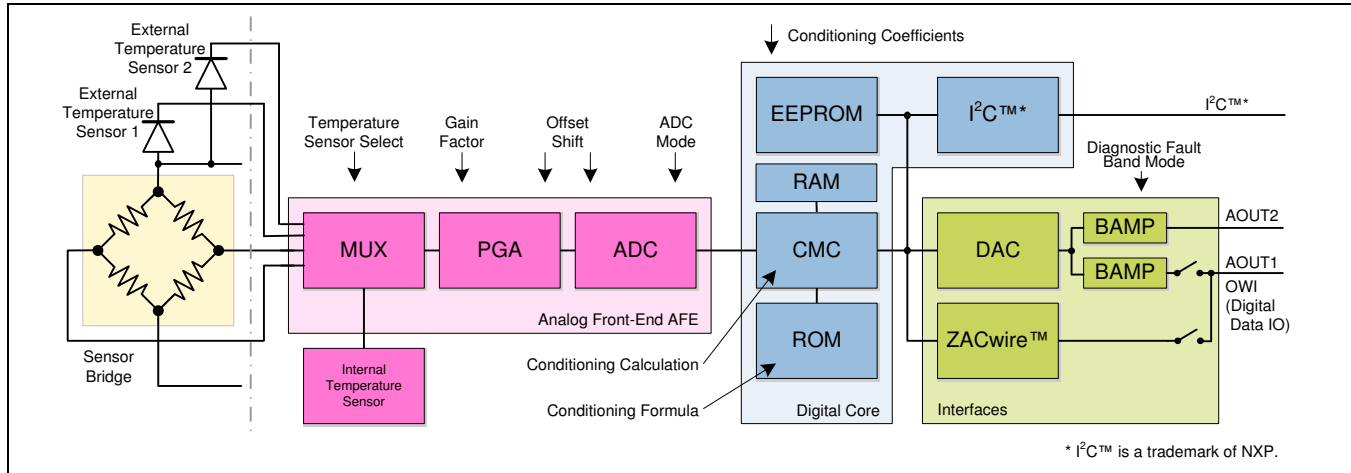

Ordering Information *(See section 7 in the data sheet for additional options.)*

Product Sales Code	Description	Package
ZSSC3154BA1D	ZSSC3154 Die - Temperature Range -40 to 125 °C	Waffle pack
ZSSC3154BA2R	ZSSC3154 QFN32 5x5mm - Temperature Range -40 to 125 °C	Reel
ZSSC3154KIT	ZSSC3154 SSC Evaluation Kit: Communication Board, SSC Board, Sensor Replacement, Software, Documentation, 5 QFN32 5x5mm Samples	Kit

Sales and Further Information		www.zmdi.com	SSC@zmdi.com
Zentrum Mikroelektronik Dresden AG Global Headquarters Grenzstrasse 28 01109 Dresden, Germany Central Office: Phone +49.351.8822.0 Fax +49.351.8822.600	ZMD America, Inc. 1525 McCarthy Blvd., #212 Milpitas, CA 95035-7453 USA USA Phone +855.275.9634 Phone +408.883.6310 Fax +408.883.6358	Zentrum Mikroelektronik Dresden AG, Japan Office 2nd Floor, Shinbashi Tokyu Bldg. 4-21-3, Shinbashi, Minato-ku Tokyo, 105-0004 Japan Phone +81.3.6895.7410 Fax +81.3.6895.7301	ZMD FAR EAST, Ltd. 3F, No. 51, Sec. 2, Keelung Road 11052 Taipei Taiwan Phone +886.2.2377.8189 Fax +886.2.2377.8199
Zentrum Mikroelektronik Dresden AG, Korea Office U-space 1 Building 11th Floor, Unit JA-1102 670 Sampyeong-dong Bundang-gu, Seongnam-si Gyeonggi-do, 463-400 Korea Phone +82.31.950.7679 Fax +82.504.841.3026	European Technical Support Phone +49.351.8822.7.772 Fax +49.351.8822.87.772		
European Sales (Stuttgart) Phone +49.711.674517.55 Fax +49.711.674517.87955	DISCLAIMER: This information applies to a product under development. Its characteristics and specifications are subject to change without notice. Zentrum Mikroelektronik Dresden AG (ZMD AG) assumes no obligation regarding future manufacture unless otherwise agreed to in writing. The information furnished hereby is believed to be true and accurate. However, under no circumstances shall ZMD AG be liable to any customer, licensee, or any other third party for any special, indirect, incidental, or consequential damages of any kind or nature whatsoever arising out of or in any way related to the furnishing, performance, or use of this technical data. ZMD AG hereby expressly disclaims any liability of ZMD AG to any customer, licensee or any other third party, and any such customer, licensee and any other third party hereby waives any liability of ZMD AG for any damages in connection with or arising out of the furnishing, performance or use of this technical data, whether based on contract, warranty, tort (including negligence), strict liability, or otherwise.		

ZSSC3154

Automotive Sensor Signal Conditioner with Dual Analog Output



The Analog Mixed Signal Company



Contents

1	Electrical Characteristics	6
1.1	Absolute Maximum Ratings	6
1.2	Operating Conditions	6
1.3	Electrical Parameters	7
1.3.1	Supply Current and Internal Supply Voltages	7
1.3.2	Analog Front-End Characteristics	7
1.3.3	Temperature Measurement	8
1.3.4	Sensor Diagnostic Tasks	8
1.3.5	A/D Conversion	9
1.3.6	D/A Conversion and Analog Outputs	9
1.3.7	System Response	10
1.4	Interface Characteristics and EEPROM	11
1.4.1	I2C™ Interface	11
1.4.2	ZACwire™ One Wire Interface	11
1.4.3	EEPROM	11
2	Circuit Description	12
2.1	Signal Flow	12
2.2	Application Modes	13
2.3	System Control	14
2.3.1	Main System Tasks	14
2.3.2	General Working Modes	14
2.4	Normal Operation Mode	14
2.4.1	Startup Phase	14
2.4.2	Measurement Cycle	15
2.4.3	Conditioning Calculation	15
2.5	Bridge Sensor Measurement	16
2.6	Temperature Measurement	16
2.7	Half-Bridge Sensor Measurement	16
2.8	Analog Front End	17
2.8.1	Programmable Gain Amplifier	17
2.8.2	Offset Compensation	18
2.8.3	Analog-to-Digital Converter	19

ZSSC3154

Automotive Sensor Signal Conditioner with Dual Analog Output



The Analog Mixed Signal Company



2.9	Signal Outputs	19
2.9.1	Analog Output	19
2.9.2	Sequential Analog Output	20
2.9.3	Digital Output	20
2.10	Serial Digital Interfaces.....	20
2.11	Failsafe Features	21
2.12	Overvoltage and Short Circuit Protection	21
3	Application Circuits and External Components	22
3.1	Application Circuit Examples	22
3.2	External Components	23
4	ESD Protection and EMC Specification	23
5	Pin Configuration and Package.....	24
6	Reliability and RoHS Conformity	26
7	Ordering Information	26
8	Related Documents.....	26
9	Glossary	27
10	Document Revision History	28

List of Figures

Figure 2.1	Block Diagram of the ZSSC3154.....	12
Figure 2.2	Example of Measurement Cycle with Bridge Sensor Signal and Temperature Measurement	15
Figure 2.3	Sequential Analog Output—Example Sequence if the DFBH Pin is Unconnected	20
Figure 3.1	Application Circuit with Two Analog Outputs and Diagnostic Fault Band Level Low	22
Figure 3.2	Application Circuit with Two Analog Outputs and Diagnostic Fault Band Level High	22
Figure 5.1	Pin Map and Pad Position of the ZSSC3154.....	25

List of Tables

Table 1.1	Absolute Maximum Ratings	6
Table 1.2	Operating Conditions	6
Table 1.3	Electrical Parameters.....	7
Table 1.4	Interface Characteristics and EEPROM	11
Table 2.1	Adjustable Gains and Resulting Sensor Signal Spans and Common Mode Ranges	17
Table 2.2	Extended Analog Offset Compensation Ranges (XZC)	18
Table 2.3	ADC Resolution versus Output Resolution and Sample Rate.....	19
Table 3.1	Dimensioning of External Components for the Application Examples	23
Table 5.1	Pin Configuration	24



1 Electrical Characteristics

1.1 Absolute Maximum Ratings

The absolute maximum ratings are stress ratings only. The ZSSC3154 might not function or be operable above the recommended operating conditions. Stresses exceeding the absolute maximum ratings might also damage the device. In addition, extended exposure to stresses above the recommended operating conditions might affect device reliability. ZMDI does not recommend designing to the “Absolute Maximum Ratings.”

Parameters apply in operating temperature range and without time limitations.

Table 1.1 Absolute Maximum Ratings

No.	Parameter	Symbol	Conditions	Min	Max	Unit
1.1.1	Supply voltage ¹⁾	VDDE	To VSSE	-0.3	7.7	V
1.1.2	Voltage at pins AOUT1 and AOUT2 ¹⁾	V _{AOUT1} , V _{AOUT2}	To VSSE	-0.3	7.7	V
1.1.3	Analog supply voltage ¹⁾	VDDA	To VSSA	-0.3	6.5	V
1.1.4	Digital supply voltage ¹⁾	VDD	To VSSA	-0.3	6.5	V
1.1.5	Voltage at all analog and digital pins ¹⁾	V _{AIO} , V _{DIO}	To VSSA	-0.3	VDDA +0.3	V
1.1.6	Storage temperature	T _{STG}		-40	130	°C
1.1.7	Extended storage temperature	T _{STGE}	t < 10h	-40	150	°C

¹⁾ Refer to ZSSC3154 Application Note – Power Management for a description of the protection features.

1.2 Operating Conditions

Table 1.2 Operating Conditions

No.	Parameter	Symbol	Conditions	Min	Typ	Max	Unit
1.2.1	Supply voltage ¹⁾	VDDE	To VSSE	4.5	5	5.5	V
1.2.2	Ambient temperature	T _{AMB}	EEPROM programming cycles are limited (refer to section 1.4.3)	-40		125	°C
1.2.3	Bridge resistance ^{2) 3)}	R _{BR}		1		10	kΩ

¹⁾ Refer to ZSSC3154 Application Note – Power Management for detailed specifications.
²⁾ Symmetric behavior and identical electrical properties (especially the low pass characteristic) of both sensor inputs are required. Unsymmetrical conditions of the sensor and/or external components connected to the sensor input pins can generate a failure in signal operation.
³⁾ No measurement in mass production; parameter is guaranteed by design and/or quality observation.

ZSSC3154

Automotive Sensor Signal Conditioner with Dual Analog Output

ZMDI[®]

The Analog Mixed Signal Company



1.3 Electrical Parameters

All parameter values are valid under the operating conditions specified in section 1.2 (special definitions excluded). All voltages are referenced to VSSA.

Note: See important notes at the end of Table 1.3.

Table 1.3 *Electrical Parameters*

No.	Parameter	Symbol	Conditions	Min	Typ	Max	Unit
1.3.1 Supply Current and Internal Supply Voltages							
1.3.1.1	Supply current	I_S	Excluding bridge supply current and excluding output current at pins AOUT1 and AOUT2; oscillator adjusted (typical $f_{OSC} = 2.6\text{MHz}$)			10	mA
1.3.1.2	Supply voltage sensor bridge (internally at VDDA and VSSA)	V_{VBR}	$V_{VBR} = V_{VBR_T} - V_{VBR_B}$ $R_{BR} \geq 1\text{k}\Omega$ (see 1.2.3) V_{VBR_T} is the voltage at the VBR_T pin and V_{VBR_B} is the voltage at VBR_B pin	VDDA – 0.3V		VDDA	
1.3.2 Analog Front-End Characteristics							
1.3.2.1	Input span	V_{IN_SPAN}	Analog gain: 2.8 to 420; EMC robust for $V_{IN_SPAN} \geq 6\text{mV/V}$	1		267	mV/V
1.3.2.2	Analog offset compensation range	OC	Depends on gain adjustment (refer to section 2.8.2)			3.88	V_{IN_SPAN}
1.3.2.3	Parasitic differential input offset current ¹⁾	$I_{IN_OFF_85^\circ\text{C}}$	$T_{AMB} = -25^\circ\text{C}$ to 85°C	-4		4	nA
		$I_{IN_OFF_125^\circ\text{C}}$	$T_{AMB} = -40^\circ\text{C}$ to 125°C	-10		-10	nA
1.3.2.4	Common mode input range	V_{IN_CM}	Depends on gain adjustment; XZC off (refer to section 2.8.1); V_{VBR} according to 1.3.1.2	0.29		0.65	V_{VBR}
1.3.2.5	Input capacitance	C_{IN}	Capacitance at pins VBP and VBN to VSSA		10	12	nF

ZSSC3154

Automotive Sensor Signal Conditioner with Dual Analog Output



The Analog Mixed Signal Company



No.	Parameter	Symbol	Conditions	Min	Typ	Max	Unit
1.3.3 Temperature Measurement							
(Refer to section 2.4.3)							
1.3.3.1	Internal temperature diode sensitivity	ST_{TSI}	Raw values, without conditioning calculation	26		38	LSB ₁₄ /K
1.3.3.2	External temperature diode channel gain	A_{TSED}	Sensor at pins VTN1 or VTN2	-18		-12	LSB ₁₄ /mV
1.3.3.3	External temperature diode bias current	I_{TSED}	Sensor at pins VTN1 or VTN2	10	20	40	μA
1.3.3.4	External temperature diode input range ¹⁾	V_{TSED}	Related to V_{VBR_T} which is the voltage at the VBR_T pin; sensor at pins VTN1 or VTN2	0.2		1.0	V
1.3.3.5	External temperature resistor channel gain	A_{TSER}	At VDDE = 5V; sensor at pins VTN1 or VTN2	-13		-9	LSB ₁₄ /mV
1.3.3.6	External temperature resistor input range ¹⁾	V_{TSER}	Related to V_{VBR_T} which is the voltage at the VBR_T pin; sensor at pins VTN1 or VTN2	0.3		1.4	V
1.3.4 Sensor Diagnostic Tasks							
1.3.4.1	Sensor connection loss detection threshold	R_{SCC_TH}		20		100	kΩ
1.3.4.2	Maximum input capacitance for sensor connection check with sensor aging check enabled	$C_{IN_SCC/SAC}$			1	1.2	nF
1.3.4.3	Maximum input capacitance for sensor connection check with sensor short check enabled	$C_{IN_SCC/SSC}$	If input capacitance is greater than 1nF the sensor connection check high-capacitor mode must be enabled.		10	12	nF
1.3.4.4	Sensor input short detection threshold	R_{SSC_TH}		50		800	Ω

ZSSC3154

Automotive Sensor Signal Conditioner with Dual Analog Output



The Analog Mixed Signal Company



No.	Parameter	Symbol	Conditions	Min	Typ	Max	Unit
1.3.5 A/D Conversion (Refer to section 2.8.3)							
1.3.5.1	ADC resolution ¹⁾	r_{ADC}				14	Bit
1.3.5.2	DNL ¹⁾	DNL_{ADC}	$f_{OSC} = 2.6\text{MHz}$; best fit; complete AFE; V_{ADC_IN} according to 1.3.5.4			0.95	LSB
1.3.5.3	INL	INL_{ADC}	$f_{OSC} = 2.6\text{MHz}$; best fit; complete AFE; V_{ADC_IN} according to 1.3.5.4		3	8	LSB
1.3.5.4	ADC input range	V_{ADC_IN}	V_{VBR} according to 1.3.1.2	0.1		0.9	V_{VBR}
1.3.6 D/A Conversion and Analog Outputs (Pins AOUT1 and AOUT2)							
1.3.6.1	DAC resolution	r_{DAC}	Analog output; $V_{OUT} = 10\%$ to 90% of V_{DAC} ; $V_{DAC} = V_{VDDE} - V_{VSSE}$		12		Bit
1.3.6.2	Output current sink and source	$I_{OUT_SRC/SINK}$	Analog output; $V_{OUT} = 10\%$ to 90% of V_{DAC} ; $V_{DAC} = V_{VDDE} - V_{VSSE}$			1.3	mA
1.3.6.3	Short circuit current	I_{OUT_SHORT}	AOUT1 or AOUT2 to V_{DDE}/V_{SSE}	-25		25	mA
1.3.6.4	Output signal range	V_{OUT_RANGE}	Ratiometric to $V_{DAC} = V_{VDDE} - V_{VSSE}$	0.046		0.954	V_{DAC}
1.3.6.5	Output slew rate ¹⁾	SR_{OUT}	$C_{LOAD} \leq 60\text{nF}$	0.1			$V/\mu\text{s}$
1.3.6.6	Output resistance in diagnostic mode	R_{OUT_DIAG}	Diagnostic fault band: $V_{DFBL} < 4\%$ of V_{DAC} if the DFBH pin is unconnected; $V_{DFBH} > 96\%$ of V_{DAC} if the DFBH pin is connected to V_{SSA} ; V_{DFBL} is the low diagnostic level and V_{DFBH} is the high diagnostic level for indicating faults			150	Ω
1.3.6.7	Load capacitance ¹⁾	C_{LOAD}	$C3 + C_{LOAD_AOUT1}$ and $C4 + C_{LOAD_AOUT2}$ (refer to section 3)			60	nF

ZSSC3154

Automotive Sensor Signal Conditioner with Dual Analog Output



The Analog Mixed Signal Company



No.	Parameter	Symbol	Conditions	Min	Typ	Max	Unit
1.3.6.8	DNL	DNL _{OUT}		-0.95		0.95	LSB
1.3.6.9	INL	INL _{OUT}	Best fit, r _{DAC} = 12-Bit	-8		8	LSB
1.3.6.10	Output leakage current at 125°C	I _{OUT_LEAK}	In case of power or ground loss	-25		25	μA
1.3.6.11	Internal pull-up current at pin DFBH to VDDA ¹⁾	I _{DFBH_PULLUP}	For diagnostic output LOW at AOUT1 and AOUT2, do not connect the DFBH pin. For diagnostic output HIGH at AOUT1 and AOUT2, connect the DFBH pin to VSSA.		50		μA
1.3.7 System Response							
1.3.7.1	Startup time ¹⁾	t _{STARTUP}	Time to first valid output after power-on; f _{OSC} = 2.6MHz; ROM check disabled			20	ms
1.3.7.2	Response time ¹⁾	t _{RESPONSE}	100% input step; f _{OSC} = 2.6MHz			1	ms
1.3.7.3	Bandwidth ¹⁾		In comparison to analog sensor signal conditioners		1		kHz
1.3.7.4	Ratiometricity error	RE	Maximum error for VDDE = 5V to 4.5V or to 5.5V			1000	ppm
1.3.7.5	Overall failure ²⁾ AFE + ADC Deviation from ideal line including INL, gain, offset, and temperature impacts; no sensor caused effects	F _{FALL_85°C}	T _{AMB} = -20°C to 85°C		0.5		% FSO ³⁾
		F _{FALL_125°C}	T _{AMB} = -40°C to 125°C f _{OSC} = 2.6MHz, XZC off, related to digital value		1.0		% FSO
<p>1) No measurement in mass production, parameter is guaranteed by design and/or quality observation.</p> <p>2) If XZC is active, an additional overall failure of maximum 25ppm/K for XZC = 31. Failure decreases linearly for XZC < 31.</p> <p>3) FSO = Full Scale Output.</p>							

ZSSC3154

Automotive Sensor Signal Conditioner with Dual Analog Output



The Analog Mixed Signal Company



1.4 Interface Characteristics and EEPROM

Table 1.4 Interface Characteristics and EEPROM

No.	Parameter	Symbol	Conditions	Min	Typ	Max	Unit
1.4.1 I²C™* Interface							
(Refer to ZSSC3154 Functional Description for timing details.)							
1.4.1.1	I ² C™ voltage level HIGH ¹⁾	V _{I2C_HIGH}		0.8			VDDA
1.4.1.2	I ² C™ voltage level LOW ¹⁾	V _{I2C_LOW}				0.2	VDDA
1.4.1.3	Slave output level LOW ¹⁾	V _{I2C_LOW_OUT}	Open drain, I _{OL} < 2mA			0.15	VDDA
1.4.1.4	SDA load capacitance ¹⁾	C _{I2C_SDA}				400	pF
1.4.1.5	SCL clock frequency ¹⁾	f _{I2C}	f _{OSC} ≥ 2MHz			400	kHz
1.4.1.6	Internal pull-up resistor ¹⁾	R _{I2C_PULLUP}		25		100	kΩ
1.4.2 ZACwire™ One Wire Interface							
(OWI at pin AOUT1)							
1.4.2.1	OWI voltage level HIGH ¹⁾	V _{OWI_IN_H}		0.8			VDDA
1.4.2.2	OWI voltage level LOW ¹⁾	V _{OWI_IN_L}				0.2	VDDA
1.4.2.3	Slave output level LOW ¹⁾	V _{OWI_OUT_L}	Open drain, I _{OL} < 4mA			0.15	VDDA
1.4.2.4	Start window ¹⁾	t _{OWI_STARTWIN}	f _{OSC} = 2.6MHz			30	ms
1.4.3 EEPROM							
1.4.3.1	Ambient temperature for EEPROM programming	T _{AMB_EEP}		-40		125	°C
1.4.3.2	Write cycles ¹⁾	n _{EEP_WRI_85°C}	T _{AMB_EEP} ≤ 85°C			1000	
		n _{EEP_WRI_125°C}	T _{AMB_EEP} ≤ 125°C			100	
1.4.3.3	Read cycles ^{1) 2)}	n _{EEP_READ}	T _{AMB} ≤ 125°C			8 x 10 ⁸	
1.4.3.4	Data retention ¹⁾	t _{EEP_RETENTION}	Temperature Profile: ³⁾ 100000h at 55°C + 30000h at 125°C			15	a
1.4.3.5	Programming time ¹⁾	t _{EEP_WRI}	Per written word		12		ms
<p>1) No measurement in mass production; parameter is guaranteed by design and/or quality observation.</p> <p>2) Valid for the dice. Note: additional package and temperature range causes restrictions.</p> <p>3) Over lifetime and valid for the dice. Use the ZMDI Temperature Profile Calculation Sheet for temperature stress calculation. Note that the package causes additional restrictions.</p>							

* I²C™ is a trademark of NXP.

ZSSC3154

Automotive Sensor Signal Conditioner with Dual Analog Output

ZMDI®

The Analog Mixed Signal Company



2 Circuit Description

2.1 Signal Flow

The ZSSC3154 signal path consists of the analog front-end (AFE), the digital signal processing unit, two analog output stages, the one-wire interface (OWI) and an overvoltage protection circuitry. Based on a differential structure, the bridge inputs VBP and VBN are handled by two signal lines, each with a dynamic range symmetrical to the common mode potential (analog ground equal to $VDDA/2$). Therefore, it is possible to amplify positive and negative input signals within the common mode range of the signal input. The input signals are selected by the input multiplexer.

Figure 2.1 Block Diagram of the ZSSC3154

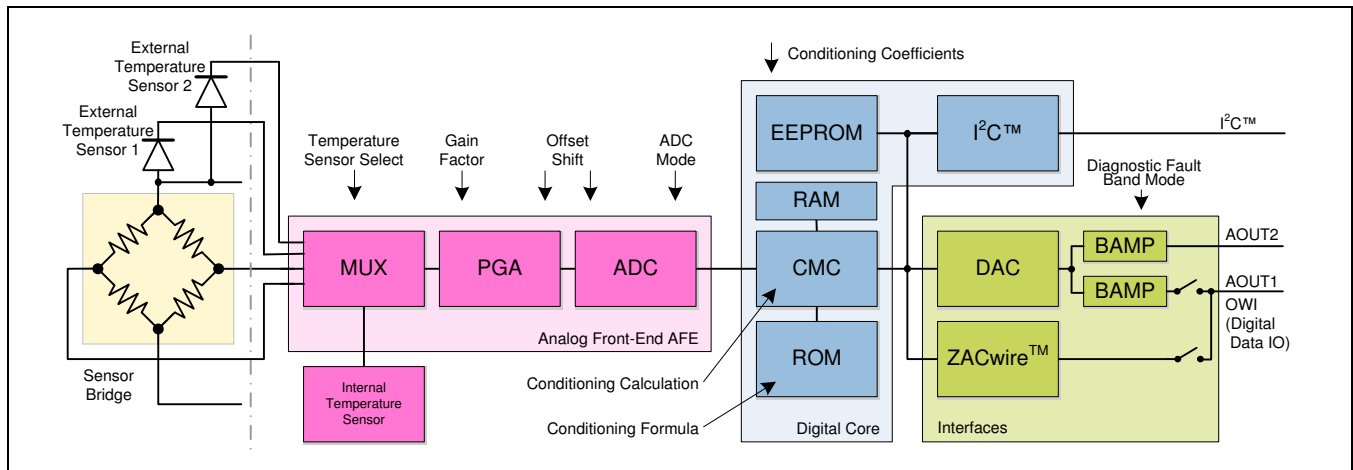

PGA	Programmable Gain Amplifier
MUX	Multiplexer
ADC	Analog-to-Digital Converter
CMC	Calibration Microcontroller
ROM	Read-Only Memory for Correction Formula and Algorithm
RAM	Volatile Memory for Configuration and Conditioning Coefficients
EEPROM	Non-volatile Memory for Configuration and Conditioning Coefficients
DAC	Digital-to-Analog Converter
BAMP	Output Buffer Amplifier
I ² C™	I ² C™ Digital Interface
ZACwire™	Digital One-Wire Interface



The multiplexer (MUX) transmits the signals from either the bridge sensor or from the selected temperature sensor to the analog-to-digital converter (ADC) in a defined sequence. The temperature sensors can either be external diodes, external thermistors (RTD), or an internal diode selected by EEPROM configuration. The differential signal from the bridge sensors is pre-amplified by the programmable gain amplifier (PGA). The ADC converts these signals into digital values.

The digital signal correction is processed in the calibration microcontroller (CMC) using a ROM-resident correction formula and sensor-specific coefficients stored in the EEPROM during calibration. The configuration data and the correction parameters can be programmed into the EEPROM by digital one-wire communication at the main output pin or by digital communication via the I²C™ interface. During the calibration procedure the digital interface can provide measurement values as well.

The conditioned bridge sensor signal is always output as a continuous analog signal at the main output pin. Depending on the programmed configuration, there are several output modes for the second analog output pin; e.g., output the inverse bridge sensor signal, output the conditioned temperature signal, or output the half-bridge sensor signal.

2.2 Application Modes

For each application, a configuration set must be established by programming the on-chip EEPROM for the following modes:

- Sensor channel
 - Input range: Select the gain adjustment of the analog front-end (AFE) with respect to the maximum sensor signal span and the zero point of the A/D conversion.
 - Analog sensor offset compensation (XZC): If required, this compensates large sensor offsets; e.g., if the sensor offset voltage is near to or larger than the sensor span.
 - Resolution/response time: Configure the A/D converter resolution. These settings influence the sampling rate and the signal integration time, and therefore the noise immunity.
- Temperature
 - Temperature measurement for the calibration: Select the internal or external temperature sensor for the compensation of temperature-related bridge sensor signal deviations.
 - Temperature measurement for the temperature output: Select the internal or external temperature sensor for the temperature measurement.
- Output
 - Output signals: Assign the measured and conditioned signals to the second analog output; e.g., inverse bridge sensor signal, temperature signal, or half-bridge sensor signal.
 - Output mode: Select the output mode for the second analog output; e.g., continuous signal or sequential analog output.



2.3 System Control

2.3.1 Main System Tasks

The calibration microcontroller (CMC) is the central system control unit and supports the following tasks and features:

- Manage the startup sequence
- Control the measurement cycle regarding to the EEPROM-stored configuration data
- Process the signal conditioning calculation (16-bit calculation for the measured signals using the ROM-resident signal conditioning formulas and the EEPROM-stored conditioning coefficients)
- Assign the conditioned output values to the analog outputs and control the output behavior
- Process the communication requests received via the digital interfaces
- Perform failsafe tasks and indicate detected errors by setting analog outputs to the diagnostic fault band

2.3.2 General Working Modes

The ZSSC3154 supports three different working modes:

- Normal Operation Mode (NOM) – for continuous processing of the signal conditioning
- Command Mode (CM) – for configuration and calibration and for access to all internal registers
- Diagnostic Mode (DM) – for failure messages

2.4 Normal Operation Mode

A configured and calibrated ZSSC3154 starts the Normal Operation Mode (NOM) immediately after power-on if there is no communication request within a startup window (refer to the *ZSSC3154 Functional Description* for details). It consists of a startup phase, the measurement cycle, the conditioning calculation, and the analog output for the sensor signals.

2.4.1 Startup Phase

After power-on, the startup phase is processed, which includes

- Settling of the internal supply voltages including the reset of the circuitry
- System start and configuration, EEPROM readout, and signature check
- ROM check, if enabled
- Processing the measurement cycle start routine including all measurements to provide the configured output signals
- One-wire communication window

If an error is detected during the startup phase, the Diagnostic Mode (DM) is activated and the analog output at the AOUT1 and AOUT2 pins remains in the diagnostic fault band range.

ZSSC3154

Automotive Sensor Signal Conditioner with Dual Analog Output



After the startup phase, the continuously running measurement and sensor signal conditioning cycle is started, and the analog or digital output of the conditioned sensor signals is activated.

2.4.2 Measurement Cycle

The measurement cycle is controlled by the CMC. Depending on EEPROM settings, the multiplexer (MUX) selects the following input signals in a defined sequence:

- Differential bridge sensor signal
- Conditioning temperature for bridge sensor signal conditioning calculation
- Temperature sensor signal
- Single-ended half-bridge sensor signal measured against an internal reference voltage
- Internal offset of the analog front end (auto-zero compensation)
- Diagnostic signals

The cycle diagram in Figure 2.2 shows the basic structure of the measurement cycle. After power-on, the startup routine is processed, which performs all required measurements to expedite acquiring an initial valid conditioned sensor output. After the startup routine, the normal measurement cycle runs.

Figure 2.2 Example of Measurement Cycle with Bridge Sensor Signal and Temperature Measurement

(For detailed descriptions of various possible cycle configurations, refer to the *ZSSC3154 Functional Description*.)

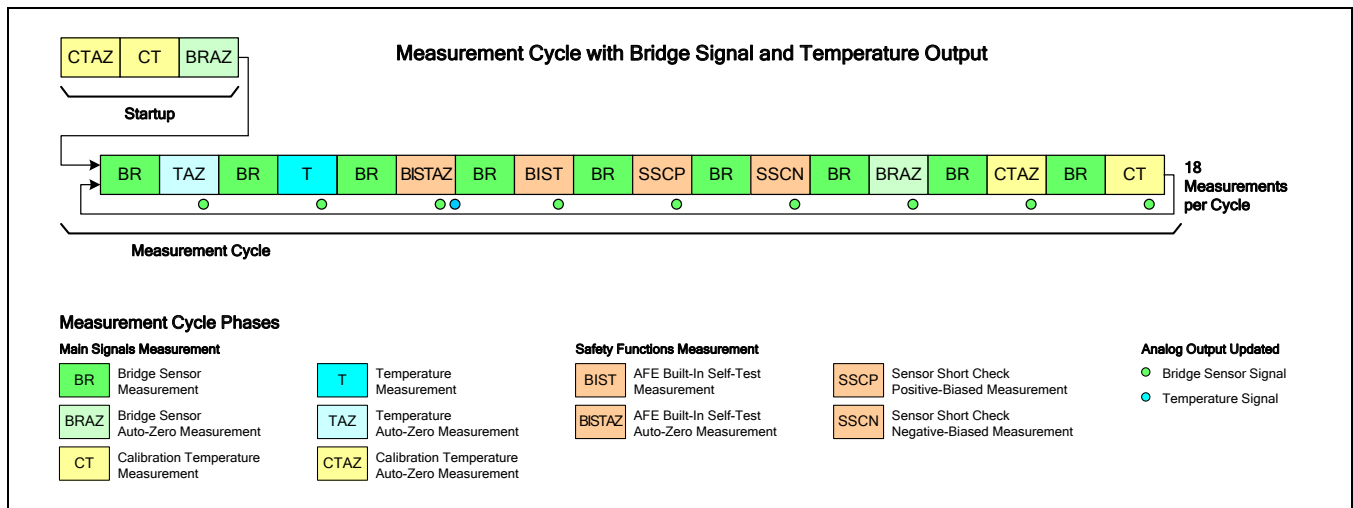

2.4.3 Conditioning Calculation

The digitalized value for the bridge signal and, if selected, for the temperature or the half-bridge signal are processed with the conditioning formulas to remove offset and temperature dependency and to compensate nonlinearity. The result is a non-negative 15-bit value in the range [0; 1).



2.5 Bridge Sensor Measurement

The ZSSC3154's main task is measuring a differential bridge sensor signal. The signal path is ratiometric and fully differential. The ratiometric reference voltage V_{REF} is equal $(V_{BR_T} - V_{BR_B})$. The internal offset of the analog front-end is eliminated by an auto-zero compensation.

The bridge sensor signal value is processed by a conditioning calculation to correct the temperature-dependent gain and to compensate the temperature-dependent offset and the nonlinearity up to 3rd order. The conditioning coefficients are stored in the EEPROM. For a detailed description of the bridge signal conditioning formula refer to the *ZSSC3154 Functional Description*.

2.6 Temperature Measurement

The ZSSC3154 supports different methods for acquiring temperature data needed for the conditioning of the sensor signal as well as for a separate temperature measurement:

- an internal pn-junction temperature sensor,
- an external pn-junction temperature sensor connected to the sensor top potential (pin VBR_T), or
- an external resistive half-bridge temperature sensor connected at the top with 1:10 resistance ratio.

Recommend resistive sensors are Pt1000, Pt10000, and Cu or Ni based positive-temperature-coefficient resistive temperature devices (PTC RTDs); e.g., KTY series.

The internal offset of the analog-front end is eliminated by an auto-zero compensation.

The temperature value is processed by a conditioning calculation to correct the gain and to compensate the offset and the 2nd order nonlinearity. The conditioning coefficients are stored in the EEPROM. For a detailed description of the temperature conditioning formula, refer to the *ZSSC3154 Functional Description*.

2.7 Half-Bridge Sensor Measurement

The ZSSC3154 supports measuring a half-bridge sensor signal referenced to an internal reference potential. The signal path is ratiometric and fully differential. The ratiometric reference voltage V_{REF} is equal $(V_{VBR_T} - V_{VBR_B})$.

The half-bridge sensor signal value is processed by a conditioning calculation to correct the temperature-dependent gain and to compensate the temperature-dependent offset and the 2nd order nonlinearity. The conditioning coefficients are stored in the EEPROM. For a detailed description of the half-bridge signal conditioning formula, refer to the *ZSSC3154 Functional Description*.

ZSSC3154

Automotive Sensor Signal Conditioner with Dual Analog Output

ZMDI[®]

The Analog Mixed Signal Company



2.8 Analog Front End

The analog front-end (AFE) consists of the multiplexer (MUX), the programmable gain amplifier (PGA), and the analog-to-digital converter (ADC).

2.8.1 Programmable Gain Amplifier

Table 2.1 shows the adjustable gains, the corresponding sensor signal input spans, and the common mode range limits.

Table 2.1 Adjustable Gains and Resulting Sensor Signal Spans and Common Mode Ranges

PGA Gain a_{IN}	Maximum Input Span V_{IN_SPAN} [mV/V] ¹⁾	Input Common Mode Range V_{IN_CM} [% VDDA] ²⁾	
		XZC = Off	XZC = On
420	1.8	29 to 65	45 to 55
280	2.7	29 to 65	45 to 55
210	3.6	29 to 65	45 to 55
140	5.4	29 to 65	45 to 55
105	7.1	29 to 65	45 to 55
70	10.7	29 to 65	45 to 55
52.5	14.3	29 to 65	45 to 55
35	21.4	29 to 65	45 to 55
26.3	28.5	29 to 65	45 to 55
14	53.75	29 to 65	45 to 55
9.3	80	29 to 65	45 to 55
7	107	29 to 65	45 to 55
2.8	267	32 to 57	Not applicable

1) Recommended maximum internal signal range is 75% of supply voltage.
Span is calculated by the following formula: $V_{IN_SPAN} = 0.75 (V_{VBR_T} - V_{VBR_B}) / a_{IN}$.

2) Refer to section 2.8.2 for an explanation of the analog offset compensation.

Recommendation: To achieve the best stability and linearity performance of the AFE, operate the PGA in a voltage range within 10% to 90% of the ratiometric reference voltage $V_{REF} = (V_{VBR_T} - V_{VBR_B})$. The gain must be selected to guarantee this constraint for the entire operating temperature range of the application and for the specified sensor bridge tolerances.

ZSSC3154

Automotive Sensor Signal Conditioner with Dual Analog Output

ZMDI[®]

The Analog Mixed Signal Company



2.8.2 Offset Compensation

The ZSSC3154 supports two methods for sensor offset compensation:

- Digital offset correction is processed during the signal conditioning calculation by the calibration micro-controller (CMC).
- Extended analog offset compensation (XZC) is achieved by adding a compensation voltage into the analog signal path. This removes large offsets up to 300% of signal span and prevents overdriving the analog signal path.

Table 2.2 *Extended Analog Offset Compensation Ranges (XZC)*

PGA Gain a_{IN}	Maximum Input Span V_{IN_SPAN} [mV/V]	Offset Shift / XZC Step [% V_{IN_SPAN}]	Maximum Offset Shift [mV/V]	Maximum Offset Shift (XZC = ± 31) [% V_{IN_SP}]
420	1.8	12.5	7.8	388
280	2.7	7.6	7.1	237
210	3.6	12.5	15.5	388
140	5.4	7.6	14.2	237
105	7.1	12.5	31	388
70	10.7	7.6	28	237
52.5	14.3	12.5	62	388
35	21.4	7.6	57	237
26.3	28.5	5.2	52	161
14	53.6	12.5	233	388
10	80	7.6	207	237
7	107	5.2	194	161
2.8	267	0.83	78	26



2.8.3 Analog-to-Digital Converter

The analog-to-digital converter is implemented using the full differential switched-capacitor technique. The A/D resolution is 14-bit. The ADC operates in the second order configuration. The conversion is largely insensitive to short-term and long-term instabilities of the clock frequency. The ADC must be configured for the following features:

- Adjustable A/D conversion time and integration phase length
- Adjustable A/D conversion input voltage range

Table 2.3 ADC Resolution versus Output Resolution and Sample Rate

ADC Resolution r_{ADC}	ADC Resolution Integration Phase	Bridge Sensor Signal Sample Rate $f_{osc} = 2.6\text{MHz}$	Averaged Bandwidth $f_{osc} = 2.6\text{MHz}$
14-bit	10-bit	0.60kHz	225Hz
	9-bit	1.13kHz	425Hz
	8-bit	2.03kHz	765Hz
	7-bit	2.54kHz	955Hz

2.9 Signal Outputs

2.9.1 Analog Output

ZSSC3154 provides two analog outputs at the AOUT1 and AOUT2 pins. The analog output behavior and the assignment of the several conditioned sensor signals to the analog outputs are configurable:

- Conditioned bridge sensor signal is always assigned to and continuously output at the AOUT1 pin.
- Conditioned temperature signal can be assigned to the analog output at the AOUT2 pin.
- Conditioned half-bridge signal can be assigned to the analog output at the AOUT2 pin.
- A function of the conditioned bridge sensor signal can be assigned to the analog output at the AOUT2 pin.
- A sequential analog output mode can be assigned to the analog output at the AOUT2 pin. The sequence of output signals includes the diagnostic fault band HIGH and LOW level, the conditioned temperature or the half-bridge signal, and a function of the conditioned bridge sensor signal (refer to section 2.9.2).
- Both analog outputs support low-pass filtering of the assigned conditioned sensor signals.
- Both analog outputs can support diagnostic procedures of the application by providing a power-on diagnostic output waveform.

For a detailed description of analog output modes and their configuration, refer to the *ZSSC3154 Functional Description*.



2.9.2 Sequential Analog Output

The sequential analog output mode allows the analog output of two conditioned sensor signals at the AOUT2 pin. The sequence of output signals includes both the low and high diagnostic fault band levels (DFB Low and DFB High, respectively) for synchronization and for a repeated verification of diagnostic levels. This is followed by output of the conditioned temperature or half-bridge signal to provide the second signal. The last transmission in the sequence is a function of the conditioned bridge sensor signal for verification of the analog output at the AOUT1 pin.

Figure 2.3 Sequential Analog Output—Example Sequence if the DFBH Pin is Unconnected

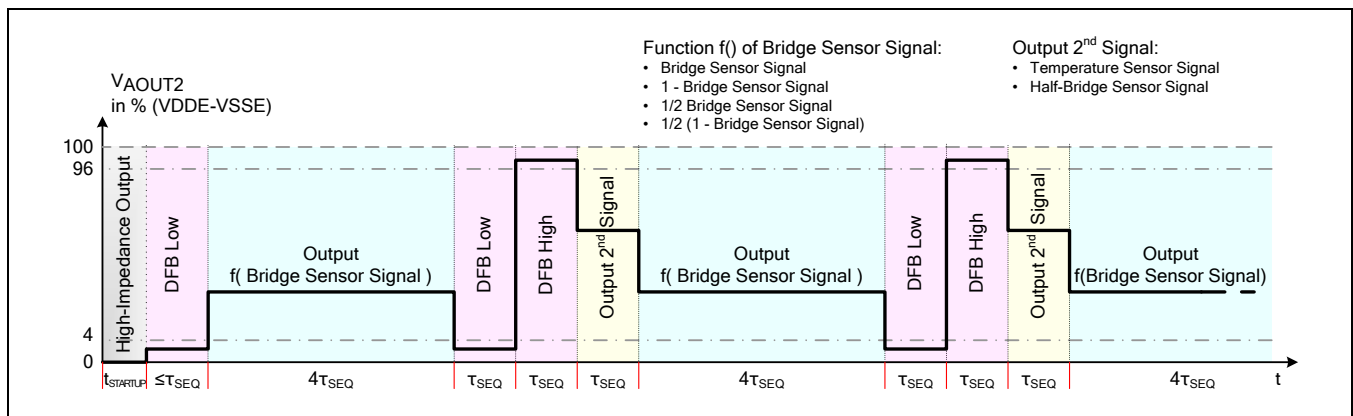

2.9.3 Digital Output

The ZSSC3154 contains a serial digital I²C™ interface that supports digital readout of the conditioned sensor signals with a resolution of 13 bits as described in section 2.10.

2.10 Serial Digital Interfaces

The ZSSC3154 contains both a serial digital I²C™ interface and a ZACwire™ interface for one-wire communication (OWI). The digital interfaces allow configuration and calibration of the sensor module. OWI communication can be used to perform an end-of-line calibration via the analog output pin AOUT1 of a completely assembled sensor module. The I²C™ interface provides the readout of the conditioned sensor signal data during normal operation mode.

For a detailed description of the digital serial interfaces and the communication protocols, refer to the ZSSC3154 *Functional Description*.



2.11 Failsafe Features

ZSSC3154 provides various failsafe tasks to control the proper function of the device and the connected sensors:

- Observation of sensors: bridge sensor aging, connection, and short check; temperature sensor check
- Observation of analog front-end (AFE): AFE built-in self-test; AFE overdrive control
- Observation of digital control unit: oscillator-fail detection; watchdog; arithmetic check
- Observation of memory content: EEPROM and ROM signatures, RAM and registers parity checks
- Observation of chip: supply power and ground loss, broken-chip check

For a detailed description of failsafe tasks and their configuration, refer to *ZSSC3154 Functional Description*.

When a failure is detected, the Diagnostic Mode (DM) is activated. The AOUT1 and AOUT2 analog outputs are set to the diagnostic fault band (DFB). The DFB output level must be selected by the wiring of the DFBH pin. If the DFBH pin is open, the outputs are switched to the diagnostic fault band level LOW. If the DFBH pin is connected to VSSA, the outputs are switched to the diagnostic fault band level HIGH. The selected DFB mode should match the connected load resistances at the analog outputs to reduce power loss if the diagnostic mode is activated.

2.12 Overvoltage and Short Circuit Protection

The ZSSC3154 is designed for a 5V ($\pm 10\%$) supply provided by an electronic control unit (ECU). Internal sub-assemblies are supplied and protected by integrated voltage regulators and limiters up to a supply voltage of 7.7V. The two analog output stages are protected by current limiters against short circuits to an external supply or ground. These functions are described in detail in *ZSSC3154 Application Note – Power Management*.

ZSSC3154 protection features are guaranteed without time limit when the device is operated in the application circuits shown in section 3.



3 Application Circuits and External Components

3.1 Application Circuit Examples

Figure 3.1 Application Circuit with Two Analog Outputs and Diagnostic Fault Band Level Low

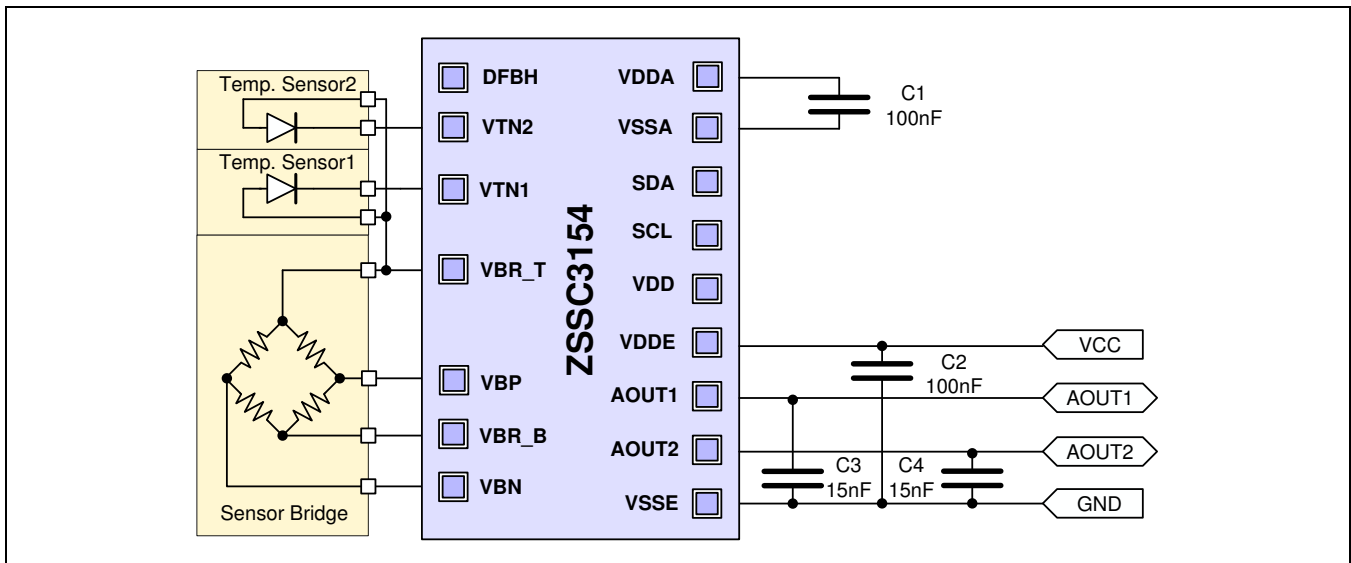
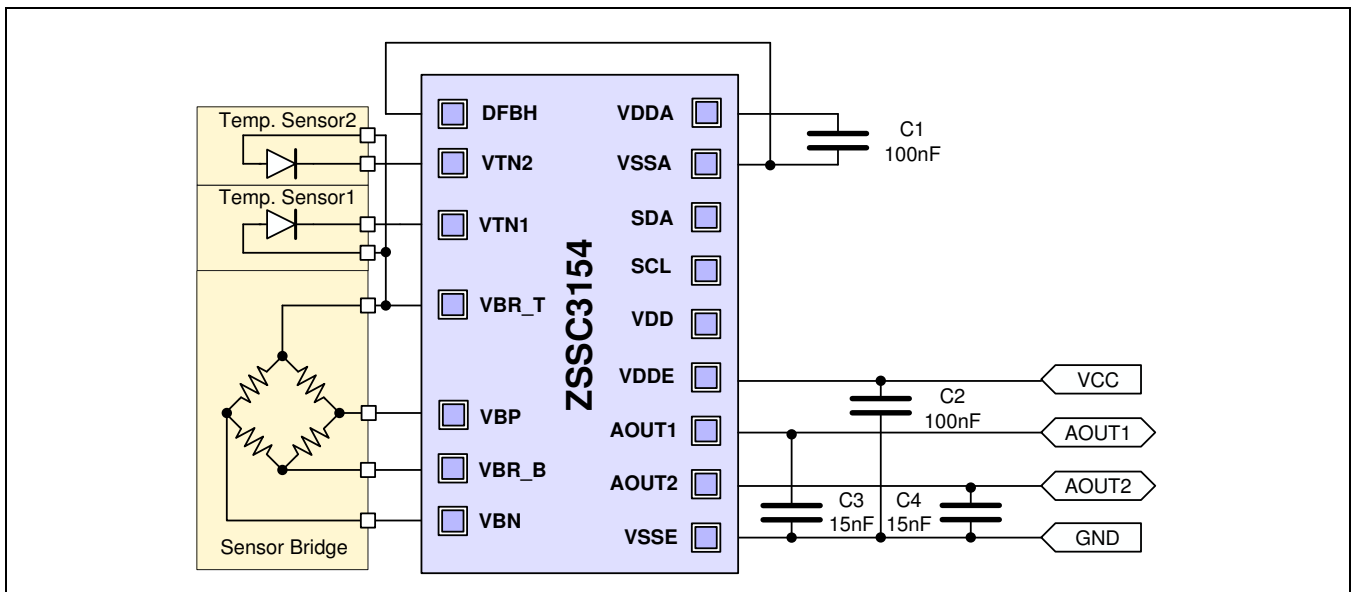

Figure 3.2 Application Circuit with Two Analog Outputs and Diagnostic Fault Band Level High





3.2 External Components

For the application circuit examples, refer to section 3.1.

Table 3.1 *Dimensioning of External Components for the Application Examples*

No.	Component	Symbol	Condition	Min	Typical	Max	Unit
3.2.1	Capacitor	C1	$V_{\max} \geq 10V$		100		nF
3.2.2	Capacitor	C2	$V_{\max} \geq 16V$		100		nF
3.2.3	Capacitor	C3	$V_{\max} \geq 16V$		15		nF
3.2.4	Capacitor	C4	$V_{\max} \geq 16V$		15		nF

The capacitor values are examples and must be adapted to the requirements of the application, in particular to the EMC requirements.

4 ESD Protection and EMC Specification

All pins have an ESD protection of >2000V according to the Human Body Model (HBM). The VDDE, VSSE, AOUT1 and AOUT2 pins have an additional ESD protection of >4000V (HBM).

The level of ESD protection has been tested with devices in QFN32 5x5 packages during the product qualification. The ESD test follows the Human Body Model with 1.5kOhm/100pF based on MIL883, Method 3015.7.

The EMC performance regarding external disturbances as well as EMC emission is documented in the *ZSSC3154 Application Note – Power Management*.

ZSSC3154

Automotive Sensor Signal Conditioner with Dual Analog Output

ZMDI[®]

The Analog Mixed Signal Company



5 Pin Configuration and Package

The ZSSC3154 is available in a QFN32 (5mm x 5mm) green package.

Table 5.1 Pin Configuration

Pin No Die	Pin No QFN32 5x5	Pin Name	Description	Notes
1	1	VDDA	Positive Analog Supply Voltage	Internal analog power supply
2	2	VSSA	Negative Analog Supply Voltage	Internal analog ground
3	3	SDA	I ² C Clock	Analog input, internal pull-up
4	4	SCL	I ² C Data I/O	Analog I/O, internal pull-up
6	5	VDD	Positive Digital Supply Voltage	Internal digital power supply
7	10	VDDE	Positive External Supply Voltage	Power supply, protected up to 7.7V
8	12	AOUT2	Analog Output 2	Analog I/O, protected up to 7.7V
9	14	VSSE	External Ground	Ground
10	16	AOUT1	Analog Output 1	Analog I/O, protected up to 7.7V
11	21	DFBH	Diagnostic Fault Band Mode Select	Analog Input, internal pull-up
12	22	VTN2	External Temperature Sensor 2	Analog I/O
13	23	VBN	Negative Bridge Sensor Input	Analog input
14	24	VBR_B	Negative Bridge Supply Voltage (Bottom)	Analog I/O
15	25	VBP	Positive Bridge Sensor Input	Analog input
16	26	VBR_T	Positive Bridge Supply Voltage (Top)	Analog I/O
17	27	VTN1	External Temperature Sensor 1	Analog I/O

ZSSC3154

Automotive Sensor Signal Conditioner with Dual Analog Output



The Analog Mixed Signal Company



Figure 5.1 Pin Map and Pad Position of the ZSSC3154

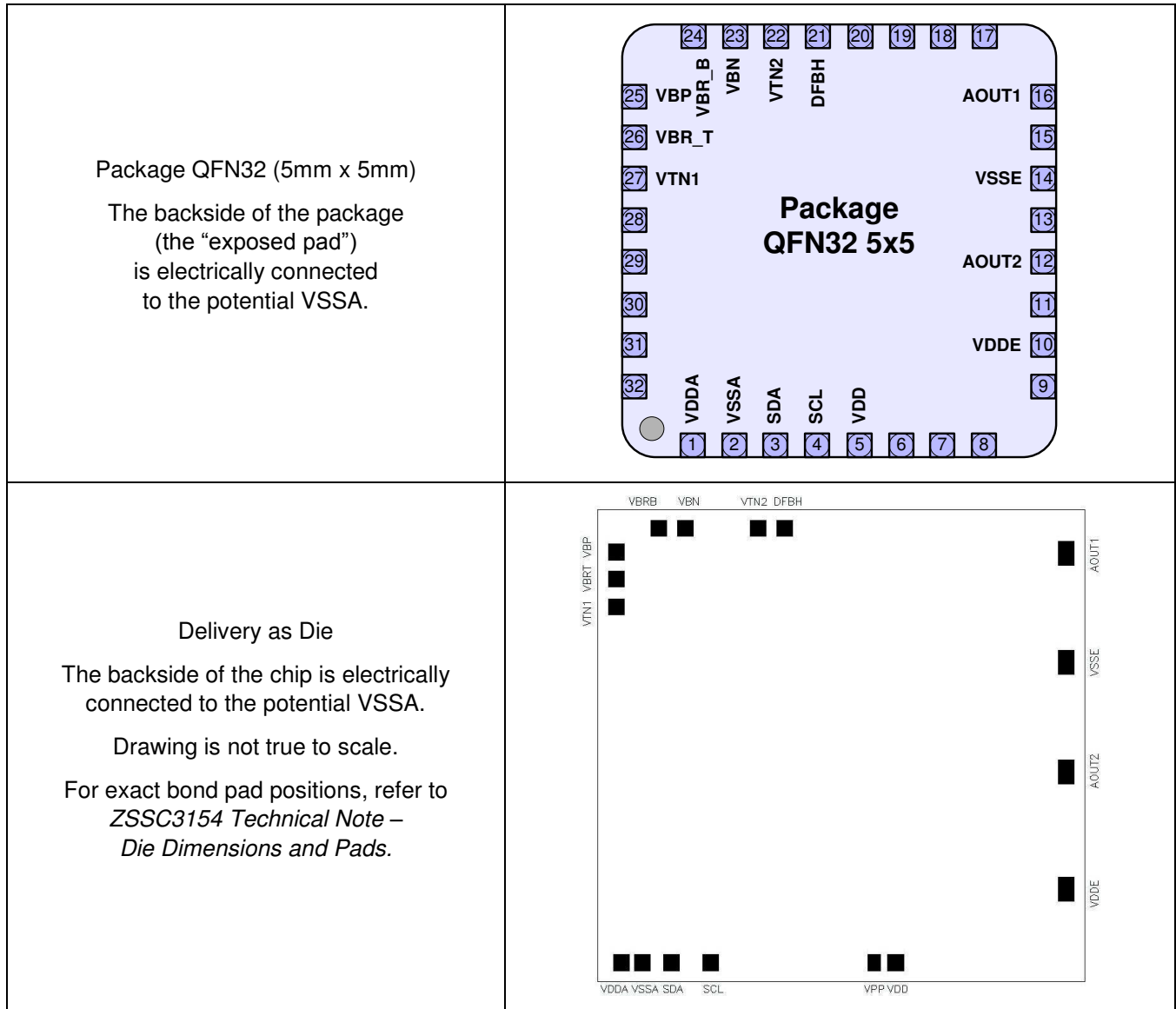

ZSSC3154

Automotive Sensor Signal Conditioner with Dual Analog Output



The Analog Mixed Signal Company



6 Reliability and RoHS Conformity

The ZSSC3154 is qualified according to the AEC-Q100 standard, operating temperature grade 0.

The IC complies with the RoHS directive and does not contain hazardous substances.

The complete RoHS declaration update can be downloaded at www.zmdi.com/quality.

7 Ordering Information

Product Sales Code	Description	Package
ZSSC3154BA1B	ZSSC3154 Die - Temperature Range -40 to 125°C	Wafer
ZSSC3154BA1C	ZSSC3154 Die - Temperature Range -40 to 125°C	Sawn on frame
ZSSC3154BA1D	ZSSC3154 Die - Temperature Range -40 to 125°C	Waffle pack
ZSSC3154BA2R	ZSSC3154 QFN32 5x5 - Temperature Range -40 to 125°C	Reel
ZSSC3154BA2V	ZSSC3154 QFN32 5x5 - Temperature Range -40 to 125°C	Tray
ZSSC3154KIT	ZSSC3154 SSC Evaluation Kit: Communication Board, SSC Board, Sensor Replacement, Software, Documentation, 5 QFN32 5x5 Samples	Kit

8 Related Documents

Note: X_xy refers to the latest version of the document.

Document	File Name
ZSSC3154 Functional Description	ZSSC3154_FunctionalDescription_Rev_X_xy.pdf
ZSSC3154 Application Note – Power Management	ZSSC3154_PowerManagement_Rev_X_xy.pdf
ZSSC3154 Technical Note – Die Dimensions and Pads	ZSSC3154_DicePads_Rev_X_xy.pdf

Visit ZMDI's website www.zmdi.com or contact your nearest sales office for the latest version of these documents.



9 Glossary

Term	Description
ADC	Analog-to-Digital Converter
AEC	Automotive Electronics Council
AFE	Analog Front-End
AOUT	Analog Output
BAMP	Buffer Amplifier
BR	Bridge Sensor
CM	Command Mode
CMC	Calibration Microcontroller
CMOS	Complementary Metal Oxide Semiconductor
DAC	Digital-to-Analog Converter
DFB	Diagnostic Fault Band Mode
DM	Diagnostic Mode
DNL	Differential Nonlinearity
EEPROM	Electrically Erasable Programmable Read Only Memory
EMC	Electromagnetic Compatibility
ESD	Electrostatic Discharge
FSO	Full Scale Output
I/O	Input/Output
I ² C [™]	Inter-Integrated Circuit, serial two-wire data bus, trademark of NXP
INL	Integral Nonlinearity
LSB	Least Significant Bit
MSB	Most Significant Bit
MUX	Multiplexer
NOM	Normal Operation Mode
PGA	Programmable Gain Amplifier
PTC	Positive-Temperature Coefficient
RAM	Random-Access Memory
RISC	Reduced Instruction Set Computer
ROM	Read Only Memory
RTD	Resistance Temperature Device

ZSSC3154

Automotive Sensor Signal Conditioner with Dual Analog Output



The Analog Mixed Signal Company



Term	Description
SAC	Sensor Aging Check
SCC	Sensor Connection Check
SSC	Sensor Short Check
XZC	Extended Zero Compensation, analog offset compensation

10 Document Revision History

Revision	Date	Description
1.00	June 8, 2012	First release.
1.10	June 14, 2012	Specification of input capacitance added (see 1.3.2.5, 1.3.4.2, 1.3.4.3). Minor edits.
1.20	June 18, 2013	Update for description of external resistive half-bridge temperature sensor and addition of recommended resistive sensors for temperature measurement in section 2.6. Update for contact information and images for cover and headers.

Sales and Further Information		www.zmdi.com	SSC@zmdi.com
Zentrum Mikroelektronik Dresden AG Global Headquarters Grenzstrasse 28 01109 Dresden, Germany Central Office: Phone +49.351.8822.0 Fax +49.351.8822.600	ZMD America, Inc. 1525 McCarthy Blvd., #212 Milpitas, CA 95035-7453 USA USA Phone +855.275.9634 Phone +408.883.6310 Fax +408.883.6358	Zentrum Mikroelektronik Dresden AG, Japan Office 2nd Floor, Shinbashi Tokyu Bldg. 4-21-3, Shinbashi, Minato-ku Tokyo, 105-0004 Japan Phone +81.3.6895.7410 Fax +81.3.6895.7301	ZMD FAR EAST, Ltd. 3F, No. 51, Sec. 2, Keelung Road 11052 Taipei Taiwan Phone +886.2.2377.8189 Fax +886.2.2377.8199
Zentrum Mikroelektronik Dresden AG, Korea Office U-space 1 Building 11th Floor, Unit JA-1102 670 Sampyeong-dong Bundang-gu, Seongnam-si Gyeonggi-do, 463-400 Korea Phone +82.31.950.7679 Fax +82.504.841.3026	European Technical Support Phone +49.351.8822.7.772 Fax +49.351.8822.87.772		
European Sales (Stuttgart) Phone +49.711.674517.55 Fax +49.711.674517.87955	DISCLAIMER: This information applies to a product under development. Its characteristics and specifications are subject to change without notice. Zentrum Mikroelektronik Dresden AG (ZMD AG) assumes no obligation regarding future manufacture unless otherwise agreed to in writing. The information furnished hereby is believed to be true and accurate. However, under no circumstances shall ZMD AG be liable to any customer, licensee, or any other third party for any special, indirect, incidental, or consequential damages of any kind or nature whatsoever arising out of or in any way related to the furnishing, performance, or use of this technical data. ZMD AG hereby expressly disclaims any liability of ZMD AG to any customer, licensee or any other third party, and any such customer, licensee and any other third party hereby waives any liability of ZMD AG for any damages in connection with or arising out of the furnishing, performance or use of this technical data, whether based on contract, warranty, tort (including negligence), strict liability, or otherwise.		