

# Data Sheet

Rev. 1.00 /February 2013

# ZSPM4523

High-Efficiency Solar PV MPPT Regulator for  
Super Capacitor Systems



*Power and Precision*



# ZSPM4523

High-Efficiency Solar PV MPPT Regulator for Super Cap Systems

**ZMDI**<sup>®</sup>

The Analog Mixed Signal Company



## Brief Description

The ZSPM4523 is a DC/DC synchronous switching super capacitor charger with fully integrated power switches, internal compensation, and full fault protection. It uses a temperature-independent photovoltaic maximum power point tracking (MPPT) calculator to optimize power output from the source during Full-Charge Mode. Its 1MHz switching frequency allows using small filter components, which results in smaller board space and reduced bill-of-material costs.

In Full-Charge Mode, the duty cycle is controlled by the MPPT function. Once the termination voltage is reached, the regulator operates in Constant Voltage Mode. When the regulator is disabled (the EN pin is low), the device draws 10 $\mu$ A (typical) quiescent current from V<sub>OUT</sub>.

The ZSPM4523 integrates a wide range of protection circuitry, including input supply under-voltage lockout, output over-voltage protection, current limiting, and thermal shutdown.

The ZSPM4523 includes supervisory reporting via the NFLT (Inverted Fault) open-drain output to interface other components in the system. Device programming is achieved by the I<sup>2</sup>C<sup>™</sup>\* interface through the SCL and SDA pins.

## Benefits

- Up to 1.5A continuous output current
- High efficiency – up to 92% at typical load

## Features

- Temperature-independent MPPT regulation
- V<sub>OUT</sub> reverse-current blocking
- Programmable temperature-compensated termination voltage: 2.48 to 2.74 V  $\pm$  1%
- User programmable maximum charge current: 50mA to 1500mA
- Input supply under-voltage lockout
- Full protection for V<sub>OUT</sub> over-voltage
- I<sup>2</sup>C<sup>™</sup> program interface with EEPROM registers
- Charge status indication

## Related ZMDI Smart Power Products

- ZSPM4521 High-Efficiency Charger for Li-Ion Batteries with MPPT Regulator
- ZSPM4551 High-Efficiency Charger for Li-Ion Batteries
- ZSPM4121 Ultra-low Power Under-Voltage Switch
- ZSPM4141 Ultra-Low-Power Linear Regulator

## Available Support

- Evaluation Kit
- Support Documentation

## Physical Characteristics

- Wide input voltage range: 3.2V to 7.2V
- Junction operating temperature -40 $^{\circ}$ C to 125 $^{\circ}$ C
- Packaged in a 16-pin PQFN (4mm x 4mm)

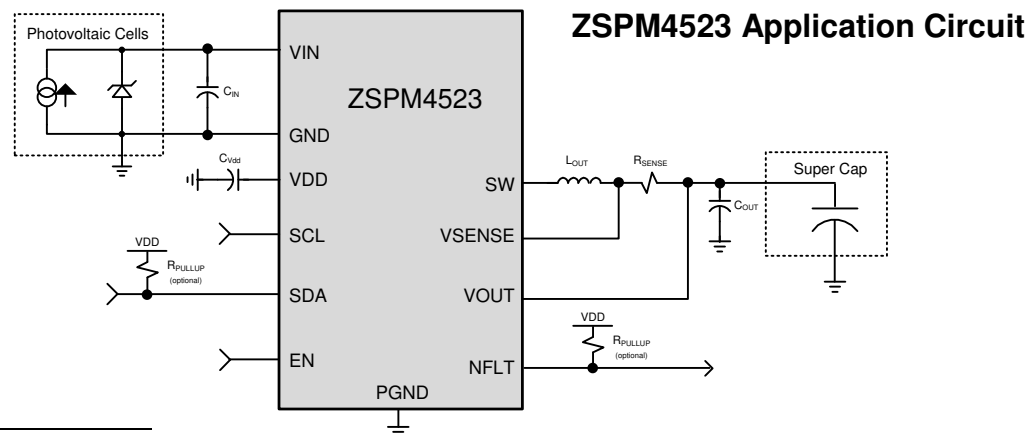

\* I<sup>2</sup>C<sup>™</sup> is a trademark of NXP.

For more information, contact ZMDI via [analog@zmdi.com](mailto:analog@zmdi.com).

# ZSPM4523

High-Efficiency Solar PV MPPT Regulator for Super Cap Systems



The Analog Mixed Signal Company



## ZSPM4523 Block Diagram

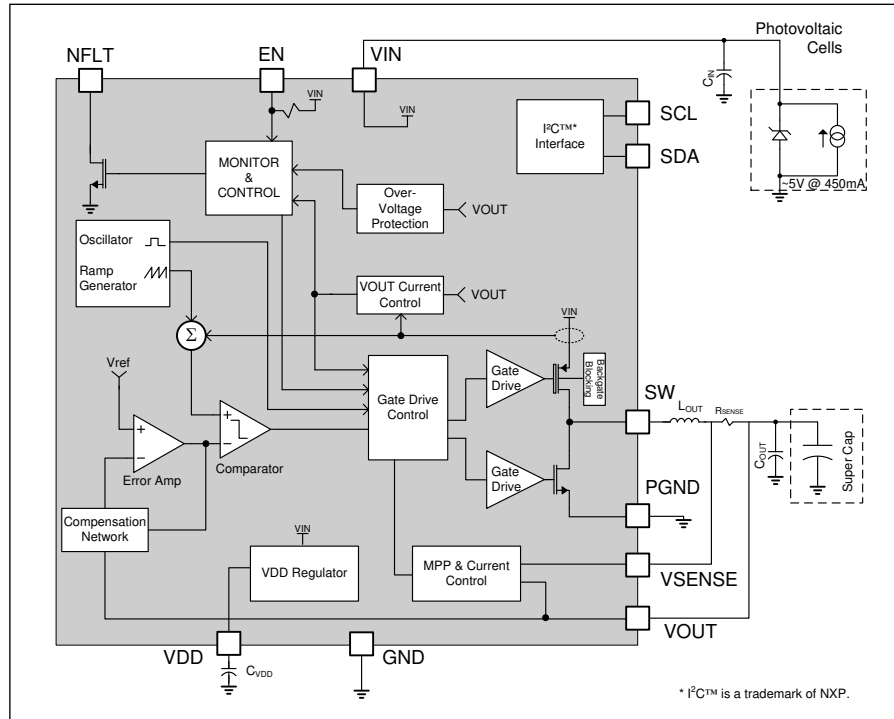

### Typical Applications

- Portable solar chargers
- Off-grid systems
- Wireless sensor networks

## Ordering Information

Ordering Code	Description	Package
ZSPM4523AA1W	ZSPM4523 High-Efficiency Regulator for Super Cap Systems	16-pin PQFN / 7" Reel (1000 parts)
ZSPM4523AA1R	ZSPM4523 High-Efficiency Regulator for Super Cap Systems	16-pin PQFN / 13" Reel (3300 parts)
ZSPM4523KIT	ZSPM4523 Evaluation Kit	

## Sales and Further Information

[www.zmdi.com](http://www.zmdi.com)

[Analog@zmdi.com](mailto:Analog@zmdi.com)

<b>Zentrum Mikroelektronik Dresden AG</b> Grenzstrasse 28 01109 Dresden Germany  Phone +49.351.8822.7.776 Fax +49.351.8822.8.7776	<b>ZMD America, Inc.</b> 1525 McCarthy Blvd., #212 Milpitas, CA 95035-7453 USA  Phone +855.275.9634 (USA) Phone +408.883.6310 Fax +408.883.6358	<b>Zentrum Mikroelektronik Dresden AG, Japan Office</b> 2nd Floor, Shinbashi Tokyu Bldg. 4-21-3, Shinbashi, Minato-ku Tokyo, 105-0004 Japan  Phone +81.3.6895.7410 Fax +81.3.6895.7301	<b>ZMD Far East, Ltd.</b> 3F, No. 51, Sec. 2, Keelung Road 11052 Taipei Taiwan  Phone +886.2.2377.8189 Fax +886.2.2377.8199	<b>Zentrum Mikroelektronik Dresden AG, Korea Office</b> U-space 1 Building 11th Floor, Unit JA-1102 670 Sampyeong-dong Bundang-gu, Seongnam-si Gyeonggi-do, 463-400 Korea  Phone +82.31.950.7679 Fax +82.504.841.3026
---	--	---	--	--

**DISCLAIMER:** This information applies to a product under development. Its characteristics and specifications are subject to change without notice. Zentrum Mikroelektronik Dresden AG (ZMD AG) assumes no obligation regarding future manufacture unless otherwise agreed to in writing. The information furnished hereby is believed to be true and accurate. However, under no circumstances shall ZMD AG be liable to any customer, licensee, or any other third party for any special, indirect, incidental, or consequential damages of any kind or nature whatsoever arising out of or in any way related to the furnishing, performance, or use of this technical data. ZMD AG hereby expressly disclaims any liability of ZMD AG to any customer, licensee or any other third party, and any such customer, licensee and any other third party hereby waives any liability of ZMD AG for any damages in connection with or arising out of the furnishing, performance or use of this technical data, whether based on contract, warranty, tort (including negligence), strict liability, or otherwise.

# ZSPM4523

High-Efficiency Solar PV MPPT Regulator for Super Cap Systems



## Contents

1	ZSPM4523 Characteristics.....	6
1.1.	Absolute Maximum Ratings.....	6
1.2.	Thermal Characteristics.....	6
1.3.	Recommended Operating Conditions.....	7
1.4.	Electrical Characteristics.....	7
1.5.	I <sup>2</sup> C™ Interface Timing Requirements.....	10
2	Functional Description.....	11
2.1.	Internal Protection Features.....	12
2.1.1.	VIN Under-Voltage Lockout.....	12
2.1.2.	Internal Current Limit.....	12
2.1.3.	Thermal Shutdown.....	12
2.1.4.	VOU Over-Voltage Protection.....	12
3	Serial Interface.....	13
3.1.	I <sup>2</sup> C™ Subaddress Definition.....	13
3.2.	I <sup>2</sup> C™ Bus Operation.....	13
3.3.	Status and Configuration Registers.....	15
4	Application Circuits.....	18
4.1.	Typical Application Circuits.....	18
4.2.	Selection of External Components.....	18
4.2.1.	C <sub>OUT</sub> Output Capacitor.....	18
4.2.2.	L <sub>OUT</sub> Output Inductor.....	18
4.2.3.	C <sub>IN</sub> Bypass Capacitor for Input from Photovoltaic Source.....	18
4.2.4.	C <sub>VDD</sub> Bypass Capacitor for VDD Internal Reference Voltage Output.....	18
4.2.5.	R <sub>SENSE</sub> Output Sensing Resistor.....	19
4.2.6.	Pull-up Resistors.....	19
5	Pin Configuration and Package.....	19
5.1.	ZSPM4523 Package Dimensions.....	19
5.2.	Pin Assignments.....	20
5.3.	Pin Description.....	20
5.4.	Package Markings.....	21
6	Layout Recommendations.....	22
6.1.	Multi-Layer PCB Layout.....	22
6.2.	Single-Layer PCB Layout.....	23
7	Ordering Information.....	24
8	Related Documents.....	24
9	Document Revision History.....	25

# ZSPM4523

High-Efficiency Solar PV MPPT Regulator for Super Cap Systems



## List of Figures

Figure 2.1	ZSPM4523 Block Diagram .....	11
Figure 3.1	Subaddress in I <sup>2</sup> C™ Transmission .....	13
Figure 3.2	I <sup>2</sup> C™ STOP/START Protocol .....	14
Figure 3.3	I <sup>2</sup> C™ Data Transmission Timing .....	14
Figure 4.1	Application Circuit .....	18
Figure 5.1	PQFN-16 Package Dimensions .....	19
Figure 5.2	ZSPM4523 Pin Assignments for 16-Pin 4mm x4mm PQFN .....	20
Figure 6.1	Package and PCB Land Configuration for Multi-Layer PCB .....	22
Figure 6.2	JEDEC Standard FR4 Multi-Layer Board – Cross-Sectional View .....	22
Figure 6.3	Conducting Heat Away from the Die using an Exposed Pad Package .....	23
Figure 6.4	Application Using a Single-Layer PCB .....	24

## List of Tables

Table 1.1	Absolute Maximum Ratings .....	6
Table 1.2	Thermal Characteristics .....	6
Table 1.3	Recommended Operating Conditions .....	7
Table 1.4	Electrical Characteristics .....	7
Table 1.5	I <sup>2</sup> C™ Interface Timing Characteristics .....	10
Table 3.1	Register Description (Device Address = 48 <sub>HEX</sub> ) .....	15
Table 3.2	STATUS Register—Address 00 <sub>HEX</sub> .....	15
Table 3.3	Configuration Register CONFIG1—Address 02 <sub>HEX</sub> .....	16
Table 3.4	Configuration Register CONFIG3—Address 04 <sub>HEX</sub> .....	16
Table 3.5	Enable Configuration Register CONFIG_ENABLE—Address 11 <sub>HEX</sub> .....	17
Table 3.6	EEPROM Control Register EEPROM_CTRL—Address 12 <sub>HEX</sub> .....	17
Table 5.1	ZSPM4523 Pin Description .....	20

# ZSPM4523

High-Efficiency Solar PV MPPT Regulator for Super Cap Systems

**ZMDI**<sup>®</sup>

The Analog Mixed Signal Company



## 1 ZSPM4523 Characteristics

Important: Stresses beyond those listed under “Absolute Maximum Ratings” (section 1.1) might cause permanent damage to the device. These are stress ratings only, and functional operation of the device at these or any other conditions beyond those indicated under “Thermal Characteristics” (section 1.2) and “Recommended Operating Conditions” (section 1.3) is not implied. Exposure to absolute–maximum–rated conditions for extended periods might affect device reliability.

### 1.1. Absolute Maximum Ratings

Over operating free–air temperature range unless otherwise noted.

**Table 1.1 Absolute Maximum Ratings**

Parameter	Value <sup>1)</sup>	Unit
VIN, EN, NFLT, SCL, SDA, VOUT, VSENSE	-0.3 to 8	V
SW	-1 to 8.8	V
VDD	-0.3 to 3.6	V
Operating Junction Temperature Range, T <sub>J</sub>	-40 to 125	°C
Storage Temperature Range, T <sub>STOR</sub>	-65 to 150	°C
Electrostatic Discharge – Human Body Model <sup>2)</sup>	+/-2k	V
Electrostatic Discharge – Machine Model <sup>2)</sup>	+/-200	V
Lead Temperature (soldering, 10 seconds)	260	°C

1) All voltage values are with respect to network ground terminal.  
2) ESD testing is performed according to the respective JESD22 JEDEC standard.

### 1.2. Thermal Characteristics

**Table 1.2 Thermal Characteristics**

Parameter	Symbol	Value	Unit
Thermal Resistance Junction to Air <sup>1)</sup>	$\theta_{JA}$	50	°C/W

1) Assumes 4x4mm QFN-16 in 1 in<sup>2</sup> area of 2 oz. copper and 25 °C ambient temperature.

# ZSPM4523

High-Efficiency Solar PV MPPT Regulator for Super Cap Systems



## 1.3. Recommended Operating Conditions

**Table 1.3 Recommended Operating Conditions**

Parameter	Symbol	Min	Typ	Max	Unit
Photovoltaic Input Operating Voltage	$V_{IN}$	3.2	5.3	7.2	V
Sense Resistor	$R_{SENSE}$		50		m $\Omega$
Output Filter Inductor Typical Value <sup>1)</sup>	$L_{OUT}$		4.7		$\mu$ H
Output Filter Capacitor Typical Value <sup>2)</sup>	$C_{OUT}$		4.7		$\mu$ F
Output Filter Capacitor ESR	$C_{OUT-ESR}$			100	m $\Omega$
Input Supply Bypass Capacitor Typical Value <sup>3)</sup>	$C_{IN}$	3.3	10		$\mu$ F
VDD Supply Bypass Capacitor Value <sup>2)</sup>	$C_{VDD}$	70	100	130	nF
Operating Free Air Temperature	$T_A$	-40		85	$^{\circ}$ C
Operating Junction Temperature	$T_J$	-40		125	$^{\circ}$ C

1) For best performance, use an inductor with a saturation current rating higher than the maximum  $V_{OUT}$  load requirement plus the inductor current ripple.

2) For best performance, use a low ESR ceramic capacitor.

3) For best performance, use a low ESR ceramic capacitor. If  $C_{IN}$  is not a low ESR ceramic capacitor, add a 0.1 $\mu$ F ceramic capacitor in parallel to  $C_{IN}$ .

## 1.4. Electrical Characteristics

Electrical Characteristics,  $T_J = -40^{\circ}\text{C}$  to  $125^{\circ}\text{C}$ ,  $V_{IN} = 5.3\text{V}$  (unless otherwise noted).

**Table 1.4 Electrical Characteristics**

Parameter	Symbol	Condition	Min	Typ	Max	Unit
<b>VIN Supply Voltage</b>						
Photovoltaic Voltage Input	$V_{IN}$		3.2	5.3	7.2	V
Quiescent Current Normal Mode	$I_{CC-NORM}$	$I_{LOAD} = 0\text{A}$ , $EN \geq 2.2\text{V}$ (HIGH)		3		mA
Quiescent Current Disabled Mode	$I_{CC-DISABLE}$	$EN = 0\text{V}$		10	50	$\mu$ A
<b>VOU Leakage</b>						
Leakage Current From Output	$I_{OUT-LEAK}$	$EN = 0\text{V}$ , $V_{OUT} = 2.7\text{V}$			10	$\mu$ A
Reverse Current	$I_{OUT-BACK}$	$V_{OUT} > V_{IN}$ , $V_{OUT} = 2.7\text{V}$			10	$\mu$ A

# ZSPM4523

High-Efficiency Solar PV MPPT Regulator for Super Cap Systems

**ZMDI**<sup>®</sup>

The Analog Mixed Signal Company



Parameter	Symbol	Condition	Min	Typ	Max	Unit
<b>VIN Under-Voltage Lockout</b>						
Input Supply Under Voltage Threshold	$V_{IN-UV}$	$V_{IN}$ increasing		3.15		V
Input Supply Under Voltage Threshold Hysteresis	$V_{IN-UV-HYST}$		100	200		mV
<b>OSC</b>						
Oscillator Frequency	$f_{OSC}$		0.9	1	1.1	MHz
<b>NFLT Open Drain Output</b>						
High-Level Output Leakage	$I_{OH-NFLT}$	$V_{NFLT} = 5.3V$		0.1		$\mu A$
Low-Level Output Voltage	$V_{OL-NFLT}$	$I_{NFLT} = -1mA$			0.4	V
<b>EN/SCL/SDA Input Voltage Thresholds</b>						
High Level Input Voltage	$V_{IH}$		2.2			V
Low Level Input Voltage	$V_{IL}$				0.8	V
Input Hysteresis – EN, SCL, SCA Pins	$V_{HYST}$			200		mV
Input Leakage – EN Pin	$I_{IN-EN}$	$V_{EN}=VIN$		0.1		$\mu A$
		$V_{EN}=0V$		-2.0		$\mu A$
Input Leakage – SCL Pin	$I_{IN-SCL}$	$V_{SCL}=VIN$		55		$\mu A$
		$V_{SCL}=0V$		-0.1		$\mu A$
Input Leakage – SDA Pin	$I_{IN-SDA}$	$V_{SDA}=VIN$		0.1		$\mu A$
		$V_{SDA}=0V$		-0.1		$\mu A$
Low-Level Output Voltage	$V_{OL-SDA}$	$I_{SDA} = -1mA$			0.4	V
<b>Thermal Shutdown</b>						
Thermal Shutdown Junction Temperature	$T_{SD}$		150	170		$^{\circ}C$
TSD Hysteresis	$T_{SD-HYST}$			10		$^{\circ}C$

# ZSPM4523

High-Efficiency Solar PV MPPT Regulator for Super Cap Systems

**ZMDI**<sup>®</sup>

The Analog Mixed Signal Company



Parameter	Symbol	Condition	Min	Typ	Max	Unit
<b>Charging Regulator with <math>L_{OUT}=4.7\mu\text{H}</math> and <math>C_{OUT}=4.7\mu\text{F}</math></b>						
Output Current Limit in Full Charge Mode	$I_{OUT-FC}$	$I_{OUT}$ is user programmable; see Table 3.4.	$I_{OUT} - 5\%$	$I_{OUT}$	$I_{OUT} + 5\%$	A
Termination Voltage	$V_{OUT}$	$V_{OUT}$ is user-programmable; see Table 3.3.	$V_{OUT} - 1\%$	$V_{OUT}$	$V_{OUT} + 1\%$	V
Full Charge Timer	$t_{FC}$		200		1400	min
High-Side (HS) Switch On Resistance	$R_{DSON}$	$I_{SW} = -1\text{A}, T_J=25^\circ\text{C}$		250		$\text{m}\Omega$
Low-Side (LS) Switch On Resistance		$I_{SW} = 1\text{A}, T_J=25^\circ\text{C}$		150		$\text{m}\Omega$
Output Current	$I_{OUT}$				1.5	A
Over-Current Detect	$I_{OCD}$	HS switch current		2.5		A
$V_{OUT}$ Over-Voltage Threshold	$V_{OUT-OV}$		101% $V_{OUT}$	102% $V_{OUT}$	103% $V_{OUT}$	
$V_{OUT}$ Over-Voltage Hysteresis	$V_{OUT-OV-HYS}$		0.2% $V_{OUT}$	0.4% $V_{OUT}$	0.6% $V_{OUT}$	
Maximum Duty Cycle	$DUTY_{MAX}$			98		%

# ZSPM4523

High-Efficiency Solar PV MPPT Regulator for Super Cap Systems

**ZMDI**<sup>®</sup>

The Analog Mixed Signal Company



## 1.5. I<sup>2</sup>C™ Interface Timing Requirements

Electrical characteristics  $T_J = -40^\circ\text{C}$  to  $125^\circ\text{C}$ ,  $V_{IN} = 5.3\text{V}$ . See Figure 3.3 for an illustration of the timing specifications given in Table 1.5.

**Table 1.5** I<sup>2</sup>C™ Interface Timing Characteristics

Parameter	Symbol	Standard Mode		Fast Mode <sup>1)</sup>		Unit
		Min	Max	Min	Max	
I <sup>2</sup> C™ Clock Frequency	$f_{scl}$	0	100	0	400	kHz
I <sup>2</sup> C™ Clock High Time	$t_{sch}$	4		0.6		$\mu\text{s}$
I <sup>2</sup> C™ Clock Low Time	$t_{scl}$	4.7		1.3		$\mu\text{s}$
I <sup>2</sup> C™ Tolerable Spike Time <sup>2)</sup>	$t_{sp}$	0	50	0	50	ns
I <sup>2</sup> C™ Serial Data Setup Time	$t_{sds}$	250		100		ns
I <sup>2</sup> C™ Serial Data Hold Time	$t_{sdh}$	0		0		$\mu\text{s}$
I <sup>2</sup> C™ Input Rise Time <sup>2)</sup>	$t_{icr}$		1000		300	ns
I <sup>2</sup> C™ Input Fall Time <sup>2)</sup>	$t_{icf}$		300		300	ns
I <sup>2</sup> C™ Output Fall Time; 10pF to 400pF Bus <sup>2)</sup>	$t_{ocf}$		300		300	ns
I <sup>2</sup> C™ Bus Free Time Between Stop and Start	$t_{buf}$	4.7		1.3		$\mu\text{s}$
I <sup>2</sup> C™ Start or Repeated Start Condition Setup Time	$t_{sts}$	4.7		0.6		$\mu\text{s}$
I <sup>2</sup> C™ Start or Repeated Start Condition Hold Time	$t_{sth}$	4		0.6		$\mu\text{s}$
I <sup>2</sup> C™ Stop Condition Setup Time <sup>2)</sup>	$t_{sps}$	4		0.6		$\mu\text{s}$

1) The I<sup>2</sup>C™ interface will operate in either standard or fast mode.  
2) Parameter not tested in production.

# ZSPM4523

High-Efficiency Solar PV MPPT Regulator for Super Cap Systems



The Analog Mixed Signal Company



## 2 Functional Description

The ZSPM4523 is a fully-integrated super capacitor charger IC based on a highly-efficient switching topology. It includes a maximum power point tracking (MPPT) function to optimize its input voltage to extract the maximum possible power from a photovoltaic cell. It includes configurability for termination voltage and charge current. A 1MHz internal switching frequency facilitates low-cost LC filter combinations.

When enabled, the ZSPM4523 will provide the maximum power available from a photovoltaic cell (Full-Charge Mode) until the output voltage reaches its termination point. At that point, it will begin to regulate voltage (Constant Voltage Mode). It will do so until a fault is detected, it is disabled, or the output voltage drops below the termination point.

Figure 2.1 ZSPM4523 Block Diagram

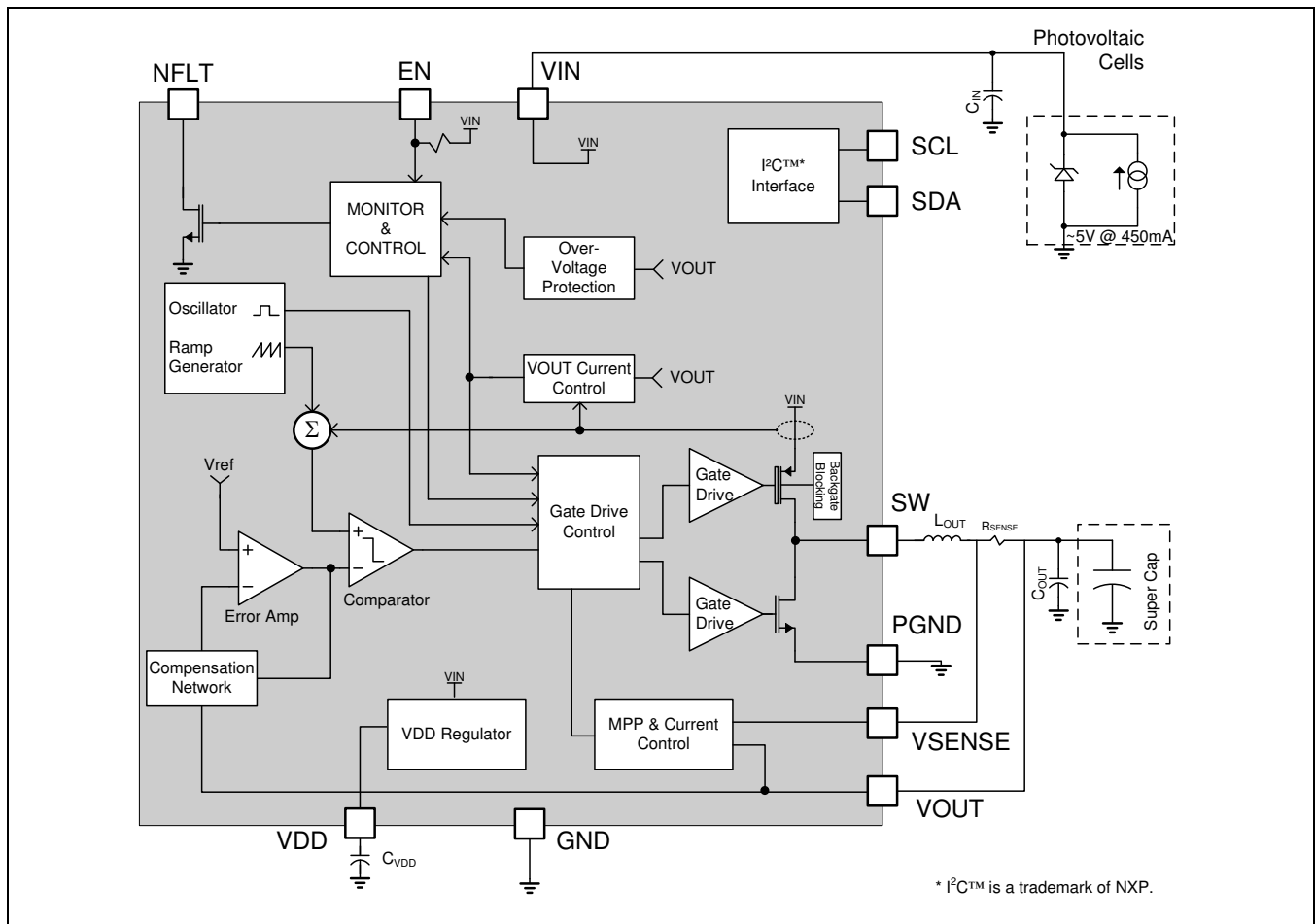

# ZSPM4523

High-Efficiency Solar PV MPPT Regulator for Super Cap Systems

**ZMDI**<sup>®</sup>

The Analog Mixed Signal Company



## 2.1. Internal Protection Features

### 2.1.1. VIN Under-Voltage Lockout

The device is held in the off state until the EN pin voltage is HIGH ( $\geq 2.2V$ ) and VIN rises to 3.15V (typical). There is a 200mV (typical) hysteresis on this input, which requires the input to fall below 2.95V (typical) before the device will disable.

### 2.1.2. Internal Current Limit

The current through the  $L_{OUT}$  inductor is sensed on a cycle-by-cycle basis, and if the current limit ( $I_{OCD}$ , see section 1.4) is reached, it will abbreviate the cycle. Current limit is always active when the regulator is enabled.

### 2.1.3. Thermal Shutdown

If the junction temperature of the ZSPM4523 exceeds 170°C (typical), the SW output will tri-state to protect the device from damage. The NFLT and all other protection circuitry will stay active to inform the system of the failure mode. Once the device cools to 160°C (typical), the device will attempt to start up again. If the device reaches 170°C, the shutdown/restart sequence will repeat.

### 2.1.4. VOUT Over-Voltage Protection

The ZSPM4523 has an output protection circuit designed to shut down the charging profile if the output voltage is greater than the termination voltage. The termination voltage can be selected by user programming, so the protection threshold is set to 2% above the termination voltage. Shutting down the charging profile puts the ZSPM4523 in a fault condition.

# ZSPM4523

High-Efficiency Solar PV MPPT Regulator for Super Cap Systems

**ZMDI**<sup>®</sup>

The Analog Mixed Signal Company



## 3 Serial Interface

The ZSPM4523 features an I<sup>2</sup>C™ slave interface that offers advanced control and diagnostic features. It supports standard and fast mode data rates and auto-sequencing, and it is compliant to I<sup>2</sup>C™ standard version 3.0.

I<sup>2</sup>C™ operation offers configuration control for termination voltages, charge currents, and charge timeouts. This configurability allows optimum charging conditions. I<sup>2</sup>C™ operation also offers fault and warning indicators. Whenever a fault is detected, the associated status bit in the STATUS register is set and the NFLT pin is pulled low. If a warning is detected, the associated status bit in the STATUS register is set, but the NFLT pin is not pulled low. (See Table 3.2.) Reading of the STATUS register resets the fault and warning status bits, and the NFLT pin is released after all fault status bits have been reset.

### 3.1. I<sup>2</sup>C™ Subaddress Definition

Figure 3.1 Subaddress in I<sup>2</sup>C™ Transmission

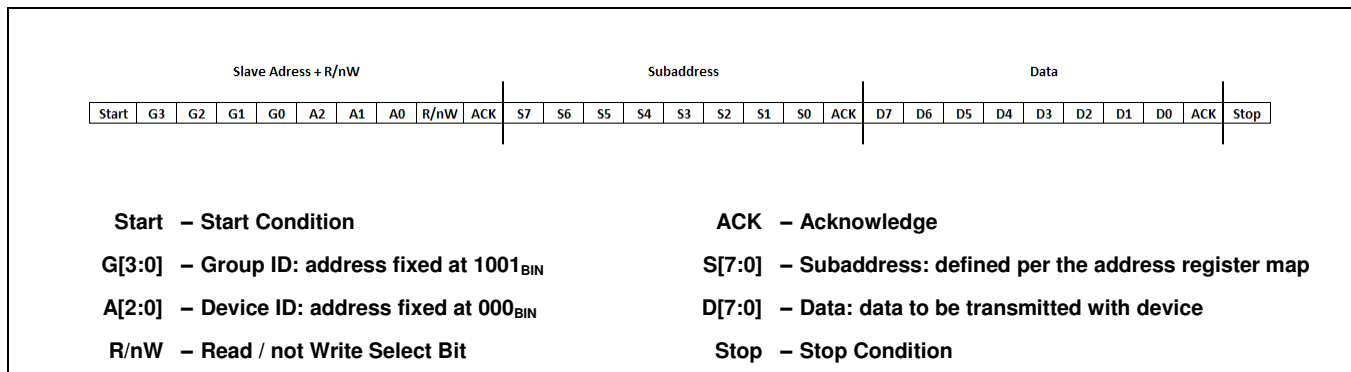

### 3.2. I<sup>2</sup>C™ Bus Operation

The ZSPM4523's I<sup>2</sup>C™ bus is a two-wire serial interface; the two lines are serial clock (SCL) and serial data (SDA) (see Figure 3.2). SDA must be connected to a positive supply (e.g., the VDD pin) through an external pull-up resistor. The devices communicating on this bus can drive the SDA line low or release it to high impedance. To ensure proper operation, setup, and hold times must be met. The device that initiates the I<sup>2</sup>C™ transaction becomes the master of the bus.

Communication is initiated by the master sending a START condition, which is a high-to-low transition on SDA while the SCL line is high. After the START condition, the device address byte is sent, most significant bit (MSB) first, including the data direction bit (read = 1; write = 0). After receiving the valid address byte, the device responds with an acknowledge (ACK). An ACK is a low on SDA during the high of the ACK-related clock pulse. On the I<sup>2</sup>C™ bus, during each clock pulse only one data bit is transferred. The data on the SDA line must remain stable during the high pulse of the clock period, as changes in the data line at this time are interpreted as START or STOP control commands. A low-to-high transition on SDA while the SCL input is high indicates a STOP condition and is sent by the master (see Figure 3.2).

# ZSPM4523

High-Efficiency Solar PV MPPT Regulator for Super Cap Systems



The Analog Mixed Signal Company



Any number of data bytes can be transferred from the transmitter to receiver between the START and the STOP conditions. Each byte of eight bits is followed by one ACK bit from the receiver. The SDA line must be released by the transmitter before the receiver can send an ACK bit. The receiver that acknowledges must pull down the SDA line during the ACK clock pulse, so that the SDA line is stable low during the high pulse of the ACK-related clock period. When a slave receiver is addressed, it must generate an ACK after each byte is received. Similarly, the master must generate an ACK after each byte that it receives from the slave transmitter. An end of data is signaled by the master receiver to the slave transmitter by not generating an acknowledge after the last byte has been clocked out of the slave. This is done by the master receiver by holding the SDA line high. The transmitter must then release the data line to enable the master to generate a STOP condition.

See section 1.5 for the timing for the periods labeled in Figure 3.3.

**Figure 3.2**  $I^2C^{\text{TM}}$  STOP/START Protocol

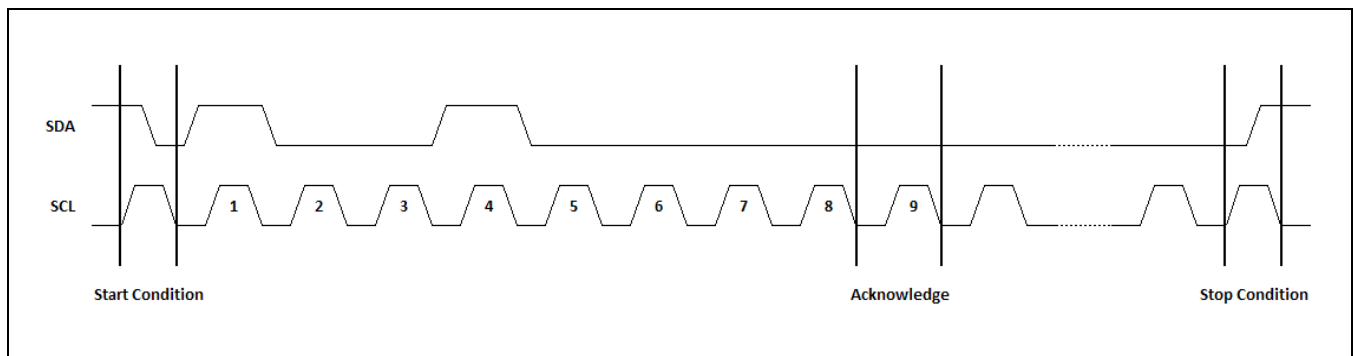

**Figure 3.3**  $I^2C^{\text{TM}}$  Data Transmission Timing

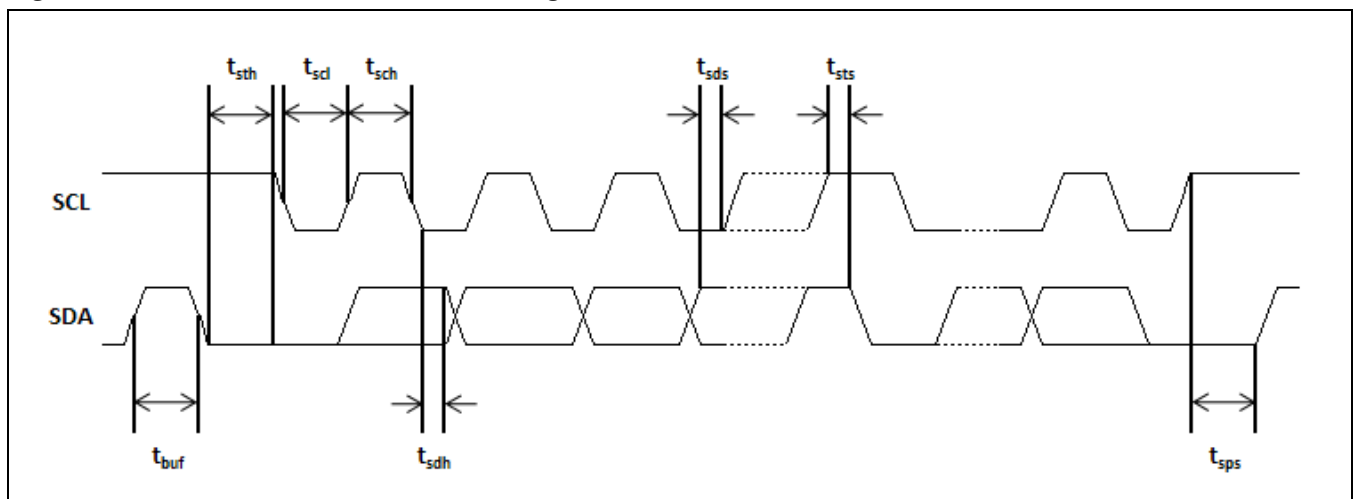

# ZSPM4523

High-Efficiency Solar PV MPPT Regulator for Super Cap Systems



## 3.3. Status and Configuration Registers

**Table 3.1 Register Description (Device Address = 48<sub>HEX</sub>)**

Register	Address (HEX)	Name	Default (HEX)	Description
0	00	STATUS	00	Status bit register.
1	N/A	N/A	N/A	Register not implemented.
2	02	CONFIG1 <sup>1)</sup>	EEPROM	Configuration register.
3	N/A	N/A	N/A	Register not implemented.
4	04	CONFIG3 <sup>1)</sup>	EEPROM	Configuration register.
5-16	N/A	N/A	N/A	Registers not implemented.
17	11	CONFIG_ENABLE	00	Enable configuration register access.
18	12	EEPROM_CTRL <sup>1)</sup>	00	EEPROM control register.

1) CONFIGx and EEPROM\_CTRL registers are only accessible when CONFIG\_ENABLE register is written with the EN\_CFG bit set to 1 (see Table 3.5).

**Table 3.2 STATUS Register—Address 00<sub>HEX</sub>**

Note: All of the STATUS register bits are READ-only.

Data Bit	D7	D6	D5	D4	D3	D2	D1	D0
Field Name	VOUT_OV	Not Used	Not Used	Not Used	TSD	Not Used	VIN_UV	Not Used
Field Name	Bit Definition					Indication <sup>1)</sup>		
VOUT_OV	VOUT Over-Voltage					Fault		
TSD	Thermal Shutdown					Warning		
VIN_UV	VIN Under-Voltage					Warning		

1) Faults cause the NFLT pin to be pulled low. Warnings do not cause the NFLT pin to be pulled low. All status bits are cleared after register read access. NFLT pin will go high impedance (open drain output) after the status register has been read and all status bits have been reset.

# ZSPM4523

High-Efficiency Solar PV MPPT Regulator for Super Cap Systems

**ZMDI**<sup>®</sup>

The Analog Mixed Signal Company



**Table 3.3 Configuration Register CONFIG1—Address 02<sub>HEX</sub>**

Note: All of the CONFIG1 register bits are READ/WRITE.

Data Bit	D7	D6	D5	D4	D3	D2	D1	D0
Field Name	Not Used		V_TERM [2:0]			Not Used		
Field Name	Bit Definition							
V_TERM [2:0]	Voltage Termination (V <sub>OUT</sub> ) Configuration: 000 – 2.48V 001 – 2.54V 010 – 2.60V 011 – 2.66V 100 – 2.68V 101 – 2.72V 110 – 2.74V 111 – (Factory use only)							

**Table 3.4 Configuration Register CONFIG3—Address 04<sub>HEX</sub>**

Note: All of the CONFIG3 register bits are READ/WRITE.

Data Bit	D7	D6	D5	D4	D3	D2	D1	D0
Field Name	MAX_CHRG_CURR [3:0]				Not Used			
Field Name	Bit Definition							
MAX_CHRG_CURR [3:0]	Maximum Charge Current (I <sub>OUT</sub> ) Configuration: 0000 – 50mA                      1000 – 800mA 0001 – 100mA                    1001 – 900mA 0010 – 200mA                   1010 – 1000mA 0011 – 300mA                   1011 – 1100mA 0100 – 400mA                   1100 – 1200mA 0101 – 500mA                   1101 – 1300mA 0110 – 600mA                   1110 – 1400mA 0111 – 700mA                   1111 – 1500mA							

# ZSPM4523

High-Efficiency Solar PV MPPT Regulator for Super Cap Systems

**ZMDI**<sup>®</sup>

The Analog Mixed Signal Company



**Table 3.5 Enable Configuration Register CONFIG\_ENABLE—Address 11<sub>HEX</sub>**

Note: The reset value for all of the CONFIG\_ENABLE register bits is 0.

Data Bit	D7	D6	D5	D4	D3	D2	D1	D0
Field Name	Not Used	Not Used	Not Used	Not Used	Not Used	Not Used	Not Used	EN_CFG
READ/WRITE	R	R	R	R	R	R	R	R/W
Field Name	Bit Definition							
EN_CFG	Enable Access Control Bit for Configuration Registers 02 and 04: 0 – Disable access 1 – Enable access							

**Table 3.6 EEPROM Control Register EEPROM\_CTRL—Address 12<sub>HEX</sub>**

Note: The reset value for all of the EEPROM\_CTRL register bits is 0.

Data Bit	D7	D6	D5	D4	D3	D2	D1	D0
Field Name	Not Used	Not Used	Not Used	Not Used	Not Used	Not Used	Not Used	EE_PROG
READ/WRITE	R	R	R	R	R	R	R	R/W
Field Name	Bit Definition							
EE_PROG <sup>1)</sup>	EEPROM Program Control Bit for Configuration Registers 02 and 04: 0 – Disable EEPROM programming 1 – Enable EEPROM programming with data from configuration registers 2 and 4							
1) EE_PROG Note: Inputs VIN and EN must be present for 200ms.								

# ZSPM4523

High-Efficiency Solar PV MPPT Regulator for Super Cap Systems



## 4 Application Circuits

### 4.1. Typical Application Circuits

Figure 4.1 Application Circuit

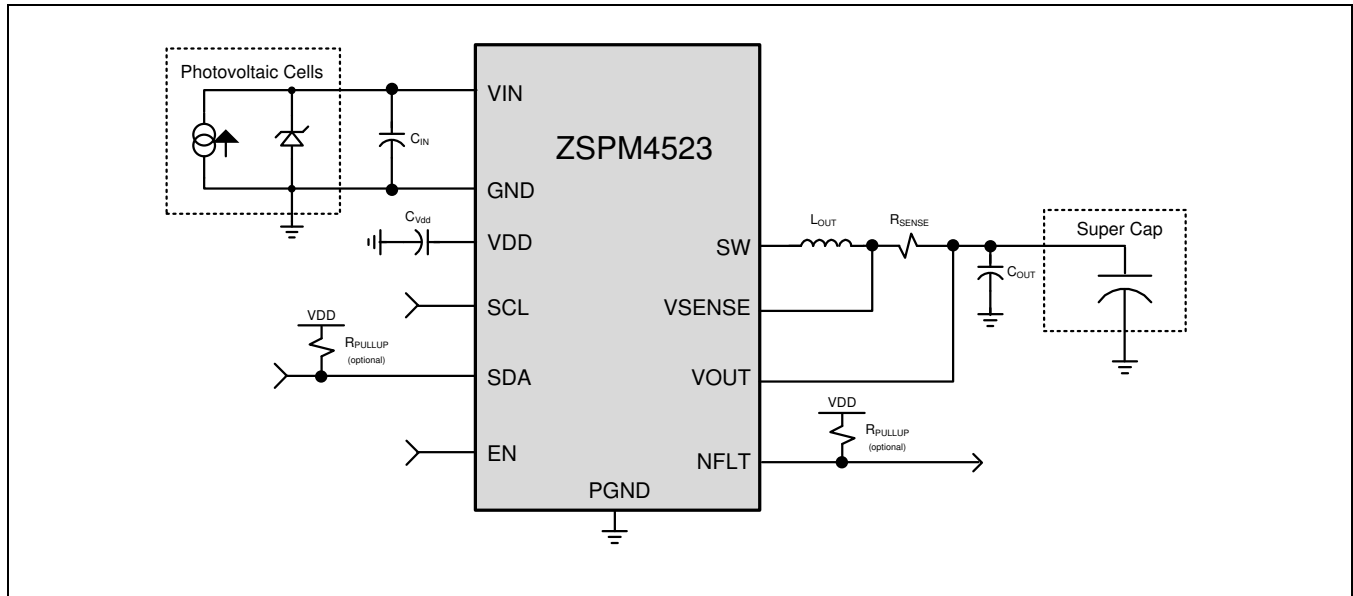

### 4.2. Selection of External Components

Note that the internal compensation is optimized for a  $4.7\mu\text{F}$  output capacitor ( $C_{OUT}$ ) and a  $4.7\mu\text{H}$  output inductor ( $L_{OUT}$ ). Table 1.3 provides recommended ranges for most of the following components.

#### 4.2.1. $C_{OUT}$ Output Capacitor

To keep the output ripple low, a low ESR (less than  $35\text{m}\Omega$ ) ceramic capacitor is recommended for the  $4.7\mu\text{F}$  output filter capacitor. The ESR should not exceed  $100\text{m}\Omega$ .

#### 4.2.2. $L_{OUT}$ Output Inductor

For best performance, an inductor with a saturation current rating higher than the maximum  $V_{OUT}$  load requirement plus the inductor current ripple should be used for the  $4.7\mu\text{H}$  output filter inductor.

#### 4.2.3. $C_{IN}$ Bypass Capacitor for Input from Photovoltaic Source

For best performance, a low ESR ceramic capacitor should be used for the  $10\mu\text{F}$  input supply bypass capacitor. If it is not a low ESR ceramic capacitor, a  $0.1\mu\text{F}$  ceramic capacitor should be added in parallel to  $C_{IN}$ .

#### 4.2.4. $C_{VDD}$ Bypass Capacitor for VDD Internal Reference Voltage Output

For best performance, a low ESR ceramic capacitor should be used for the  $100\text{nF}$  bypass capacitor from the VDD pin to ground.

# ZSPM4523

High-Efficiency Solar PV MPPT Regulator for Super Cap Systems



The Analog Mixed Signal Company



## 4.2.5. $R_{SENSE}$ Output Sensing Resistor

The typical value for the output sensing resistor is 50m $\Omega$ .

## 4.2.6. Pull-up Resistors

For proper function of the I<sup>2</sup>C™ interface, the SDA pin must be connected to a positive supply (e.g., the VDD pin) through an external pull-up resistor.

For proper function of the fault-warning signal on the NFLT pin, it must be connected to a positive supply (VDD) through an external pull-up resistor.

## 5 Pin Configuration and Package

### 5.1. ZSPM4523 Package Dimensions

Figure 5.1 PQFN-16 Package Dimensions

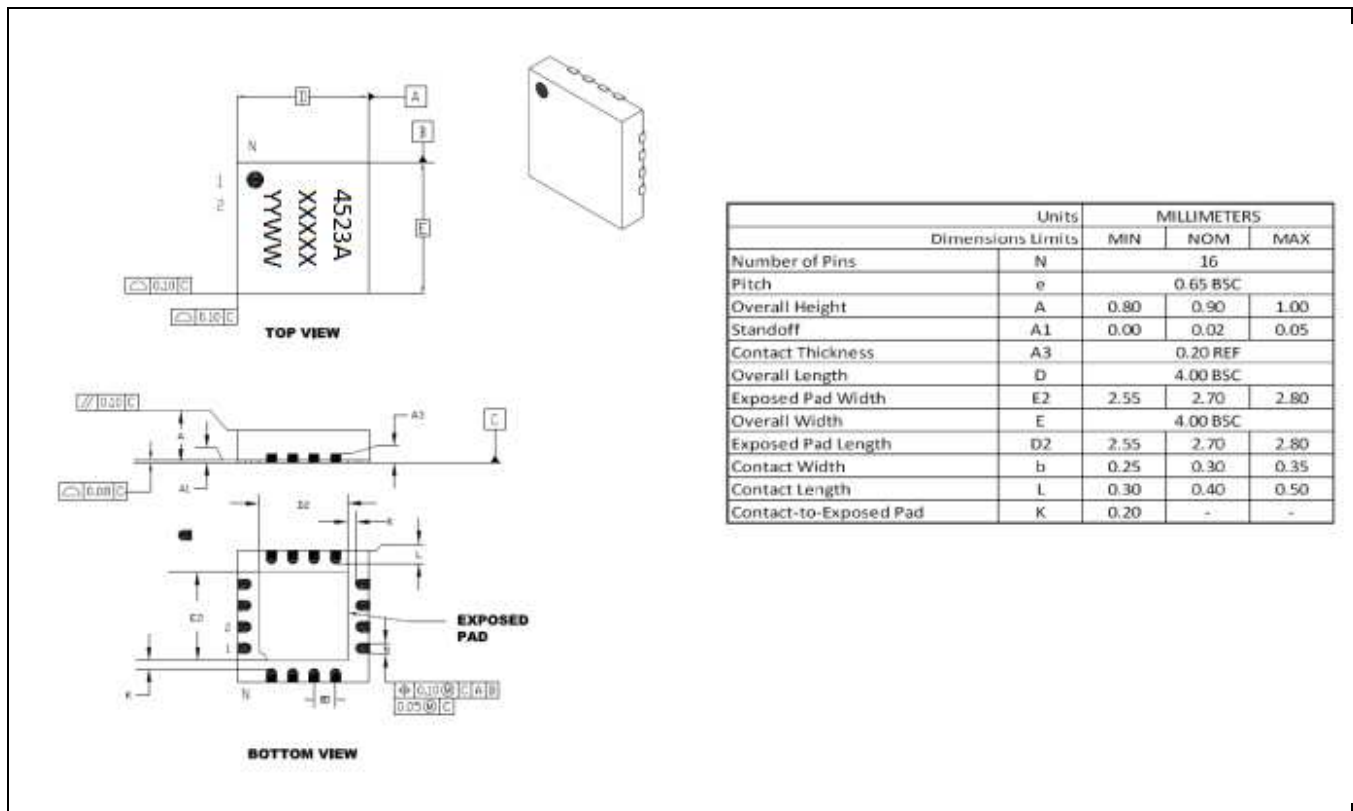

# ZSPM4523

High-Efficiency Solar PV MPPT Regulator for Super Cap Systems

**ZMDI**<sup>®</sup>

The Analog Mixed Signal Company



## 5.2. Pin Assignments

**Figure 5.2 ZSPM4523 Pin Assignments for 16-Pin 4mm x4mm PQFN**

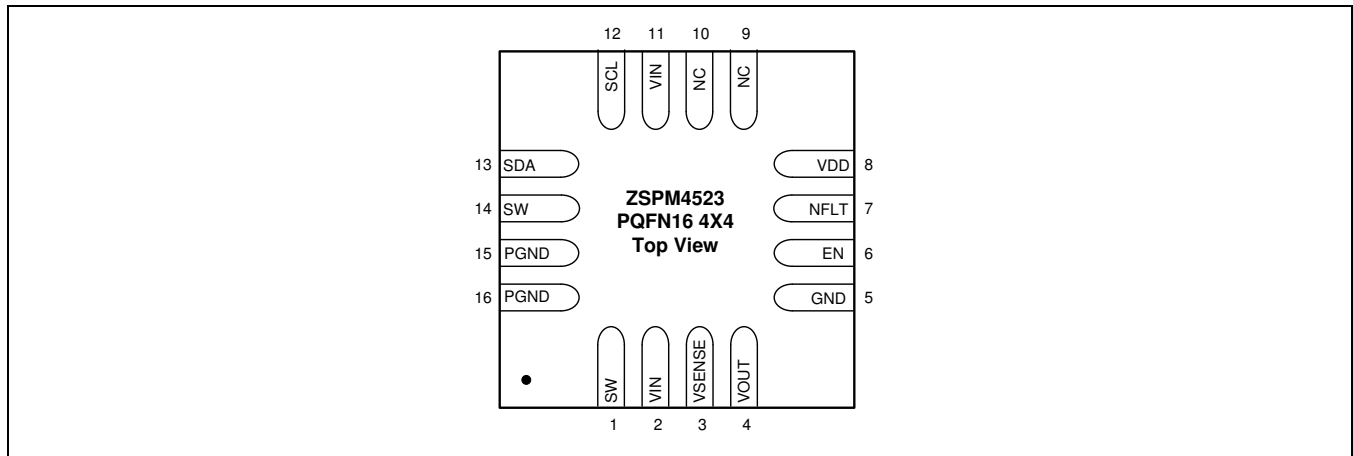

## 5.3. Pin Description

**Table 5.1 ZSPM4523 Pin Description**

Pin #	Name	Function	Description
1	SW	Switching Voltage Node	Connected to 4.7 $\mu$ H (typical) inductor L <sub>OUT</sub> . Also connect to additional SW pin 14.
2	VIN	Photovoltaic Input Voltage	Input voltage for the photovoltaic cell. Also connect to C <sub>IN</sub> . Also connect to additional VIN pin 11.
3	VSENSE	Current Sense Positive Input	Positive input for the MPPT current loop. Connect to the R <sub>SENSE</sub> resistor to V <sub>OUT</sub> and the L <sub>OUT</sub> inductor to SW.
4	VOUT	Super Cap Voltage	Regulator feedback input. Connect to the R <sub>SENSE</sub> resistor to VSENSE and the C <sub>OUT</sub> capacitor to ground across the load.
5	GND	GND	Primary ground for the majority of the device except the low-side power FET.
6	EN	Enable Input	When EN is high ( $\geq 2.2$ V), the device is enabled. Ground the pin to disable the device. Includes internal pull-up.
7	NFLT	Inverted Fault	Open-drain output.
8	VDD	Internal 3.3V Supply Output	Connect to a 100nF capacitor to GND.
9	NC	Unused	Ground this pin for applications.
10	NC	Unused	Ground this pin for applications.
11	VIN	Photovoltaic Input Voltage	Additional VIN pin for input voltage from the photovoltaic cell; connect to VIN pin 2.

# ZSPM4523

High-Efficiency Solar PV MPPT Regulator for Super Cap Systems

**ZMDI**<sup>®</sup>

The Analog Mixed Signal Company



Pin #	Name	Function	Description
12	SCL	Clock Input	I <sup>2</sup> C™ clock input.
13	SDA	Data Input/Output	I <sup>2</sup> C™ data (open-drain output).
14	SW	Switching Voltage Node	Additional SW pin; connect to SW pin 1.
15	PGND	Power GND	GND supply for internal low-side FET/integrated diode. Also connect to additional PGND pin 16.
16	PGND	Power GND	GND supply for internal low-side FET/integrated diode. Also connect to additional PGND pin 15.

## 5.4. Package Markings

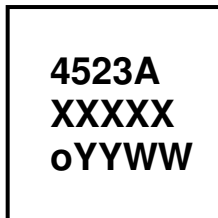

XXXXX: Lot Number (last five digits)  
O: Pin 1 mark  
YY: Year  
WW: Work Week



## 6 Layout Recommendations

To maximize the efficiency of this package for application on a single layer or multi-layer PCB, certain guidelines must be followed when laying out this part on the PCB.

### 6.1. Multi-Layer PCB Layout

The following are guidelines for mounting the exposed pad ZSPM4523 on a multi-Layer PCB with ground a plane. In a multi-layer board application, the thermal vias are the primary method of heat transfer from the package thermal pad to the internal ground plane. The efficiency of this method depends on several factors, including die area, number of thermal vias, and thickness of copper, etc.

**Figure 6.1 Package and PCB Land Configuration for Multi-Layer PCB**

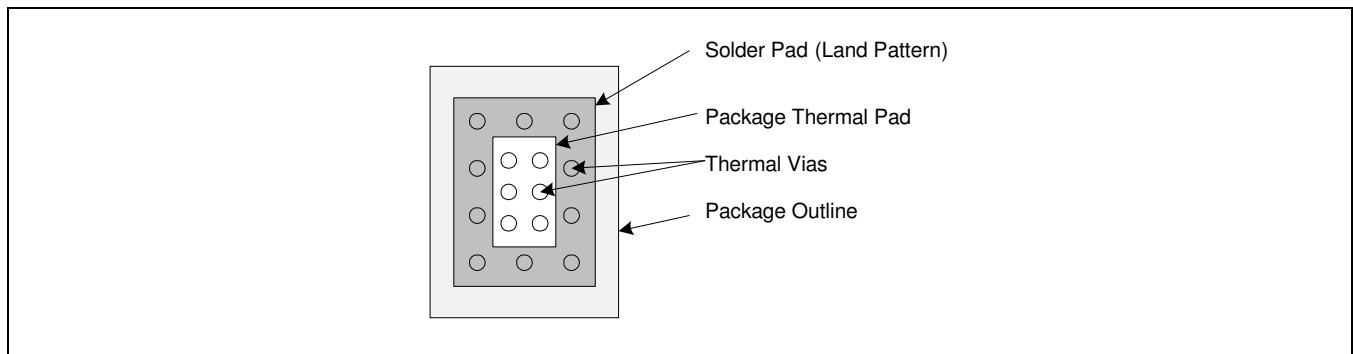

**Figure 6.2 JEDEC Standard FR4 Multi-Layer Board – Cross-Sectional View**

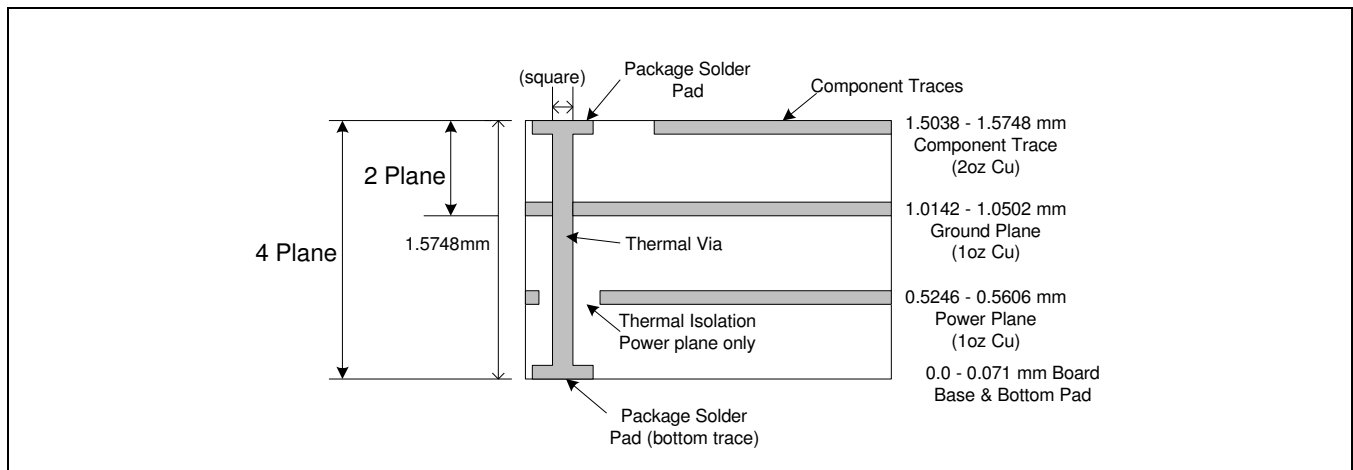

# ZSPM4523

High-Efficiency Solar PV MPPT Regulator for Super Cap Systems

**ZMDI**<sup>®</sup>

The Analog Mixed Signal Company



Figure 6.3 is a representation of how the heat can be conducted away from the die using an exposed pad package. Each application will have different requirements and limitations, and therefore the user should use sufficient copper to dissipate the power in the system. The output current rating for the linear regulators might need to be de-rated for higher ambient temperatures. The de-rated value will depend on calculated worst case power dissipation and the thermal management implementation in the application.

**Figure 6.3 Conducting Heat Away from the Die using an Exposed Pad Package**

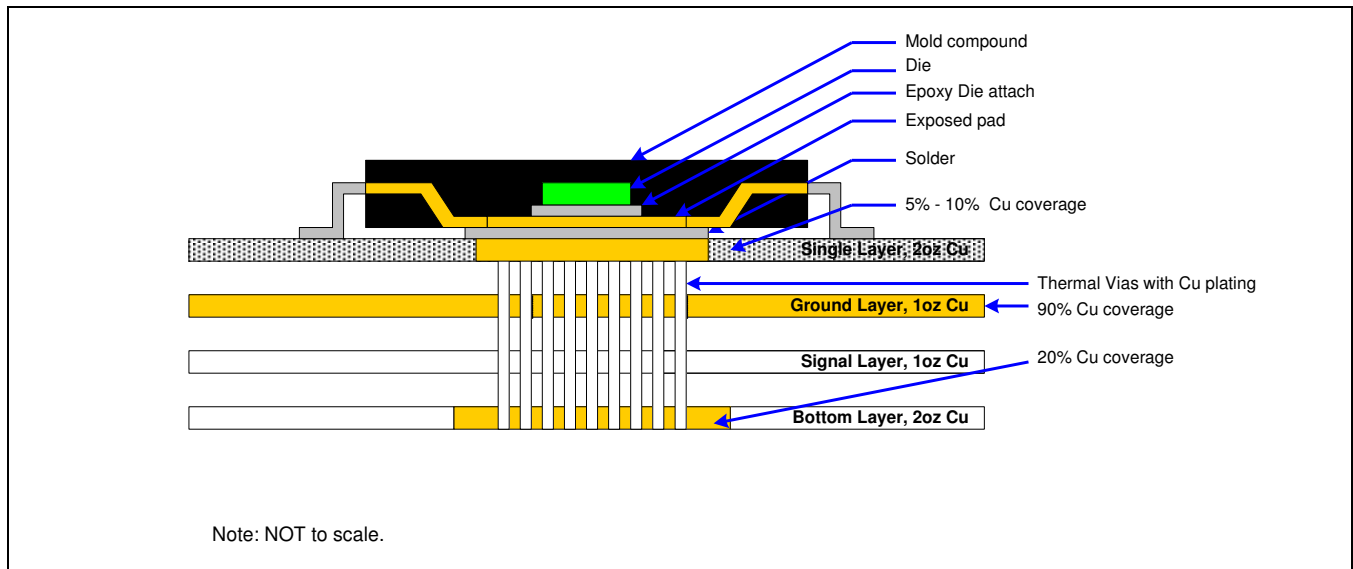

## 6.2. Single-Layer PCB Layout

Layout recommendations for a single-layer PCB: Utilize as much copper area for power management as possible. In a single-layer board application, the thermal pad is attached to a heat spreader (copper areas) by using a low thermal impedance attachment method (solder paste or thermal conductive epoxy).

In both of the methods mentioned above, it is advisable to use as much copper trace as possible to dissipate the heat.

# ZSPM4523

High-Efficiency Solar PV MPPT Regulator for Super Cap Systems

**ZMDI**<sup>®</sup>

The Analog Mixed Signal Company



**Figure 6.4 Application Using a Single-Layer PCB**

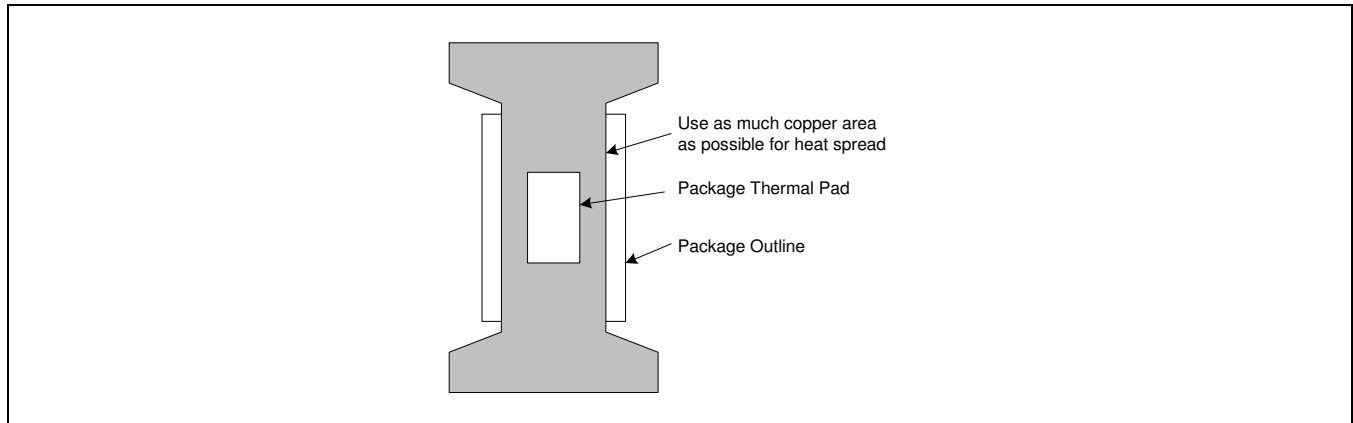

**Important:** If the attachment method is NOT implemented correctly, the functionality of the product is NOT guaranteed. Power dissipation capability will be adversely affected if the device is incorrectly mounted onto the circuit board.

## 7 Ordering Information

Ordering Code	Description	Package
ZSPM4523AA1W	ZSPM4523 High-Efficiency Regulator for Super Capacitor Systems	16-pin PQFN / 7" Reel (1000 parts)
ZSPM4523AA1R	ZSPM4523 High-Efficiency Regulator for Super Capacitor Systems	16-pin PQFN / 13" Reel (3300 parts)
ZSPM4523KIT	ZSPM4523 Evaluation Kit	

## 8 Related Documents

Document	File Name
ZSPM4523 Feature Sheet	ZSPM4523_Feature_Sheet_revX_xy.pdf
ZSPM4523 Evaluation Kit Description	ZSPM4523_Eval_Kit_Description_revX_xy.pdf
ZSPM4523 Application Note – Solar Powered Battery Management and Charging Solutions	ZSPM4523_App_Note_Solar-Batt-Charging_revX_xy.pdf

Visit ZMDI's website [www.zmdi.com](http://www.zmdi.com) or contact your nearest sales office for the latest version of these documents.

# ZSPM4523

High-Efficiency Solar PV MPPT Regulator for Super Cap Systems

**ZMDI**<sup>®</sup>

The Analog Mixed Signal Company



## 9 Document Revision History

Revision	Date	Description
1.00	February 14, 2013	First release

### Sales and Further Information

[www.zmdi.com](http://www.zmdi.com)

[Analog@zmdi.com](mailto:Analog@zmdi.com)

<b>Zentrum Mikroelektronik Dresden AG</b> Grenzstrasse 28 01109 Dresden Germany  Phone +49.351.8822.7.776 Fax +49.351.8822.8.7776	<b>ZMD America, Inc.</b> 1525 McCarthy Blvd., #212 Milpitas, CA 95035-7453 USA  Phone +855.275.9634 (USA) Phone +408.883.6310 Fax +408.883.6358	<b>Zentrum Mikroelektronik Dresden AG, Japan Office</b> 2nd Floor, Shinbashi Tokyu Bldg. 4-21-3, Shinbashi, Minato-ku Tokyo, 105-0004 Japan  Phone +81.3.6895.7410 Fax +81.3.6895.7301	<b>ZMD Far East, Ltd.</b> 3F, No. 51, Sec. 2, Keelung Road 11052 Taipei Taiwan  Phone +886.2.2377.8189 Fax +886.2.2377.8199	<b>Zentrum Mikroelektronik Dresden AG, Korea Office</b> U-space 1 Building 11th Floor, Unit JA-1102 670 Sampyeong-dong Bundang-gu, Seongnam-si Gyeonggi-do, 463-400 Korea  Phone +82.31.950.7679 Fax +82.504.841.3026
---	--	---	--	--

**DISCLAIMER:** This information applies to a product under development. Its characteristics and specifications are subject to change without notice. Zentrum Mikroelektronik Dresden AG (ZMD AG) assumes no obligation regarding future manufacture unless otherwise agreed to in writing. The information furnished hereby is believed to be true and accurate. However, under no circumstances shall ZMD AG be liable to any customer, licensee, or any other third party for any special, indirect, incidental, or consequential damages of any kind or nature whatsoever arising out of or in any way related to the furnishing, performance, or use of this technical data. ZMD AG hereby expressly disclaims any liability of ZMD AG to any customer, licensee or any other third party, and any such customer, licensee and any other third party hereby waives any liability of ZMD AG for any damages in connection with or arising out of the furnishing, performance or use of this technical data, whether based on contract, warranty, tort (including negligence), strict liability, or otherwise.

Data Sheet  
February 14, 2013

© 2013 Zentrum Mikroelektronik Dresden AG — Rev. 1.00  
All rights reserved. The material contained herein may not be reproduced, adapted, merged, translated, stored, or used without the prior written consent of the copyright owner. The information furnished in this publication is subject to changes without notice.

25 of 25