

Data Sheet

Rev. 2.00 / January 2013

ZSPM4141

Ultra-Low-Power Linear Regulator with
Minimal Quiescent Current Technology



Power and Precision



ZSPM4141

Ultra-Low-Power Linear Regulator w/ Minimal Quiescent Current Technology

ZMDI[®]

The Analog Mixed Signal Company



Brief Description

The ZSPM4141 is an ultra-low-power linear regulator optimized for minimal quiescent current losses via advanced, proprietary technology. It can improve energy efficiency and reduce heat due to power dissipation because it draws low nA-level quiescent current for light loads, yet it can regulate current loads as high as 200mA. The linear regulated output voltage is factory-configured to an option from 1.2V to 4.2V in 100mV steps. The ZSPM4141 also provides over-current protection.

Features

- Low operating voltage range: 2.5V to 5.5V
- Power-Down Mode for 100pA quiescent current
- Over-current protection: 250mA
- Output voltage options of 1.2V to 4.2V in 100mV steps (programmed at manufacturing)

Benefits

- Ultra-low 100pA quiescent current in power down mode
- Best-in-class quiescent current of 20nA at $I_{LOAD}=0$
- 0.5% DC line regulation (typical)
- Extends battery life
- Enables power harvesting applications
- High level of integration minimizes board space

Related ZMDI Smart Power Products

- ZSPM4121 Under-Voltage Load Switch for Smart Battery Management

Available Support

- ZSPM4141W12KIT Evaluation Kit
- Support Documentation

Physical Characteristics

- Package: 8-pin DFN (2mm x2mm)

Typical ZSPM4141 Application Circuits

ZSPM4141 Basic (Fixed Output) Application

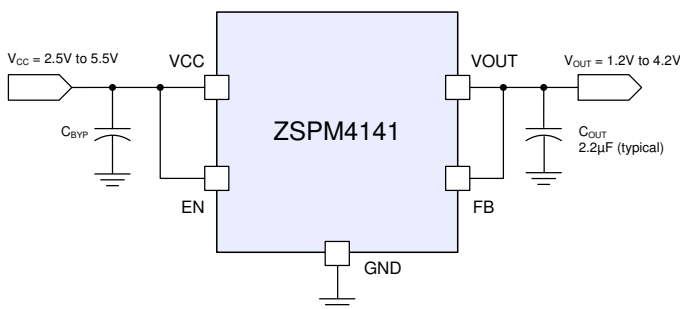

ZSPM4141A1W12 Variable VOUT via Resistor Divider

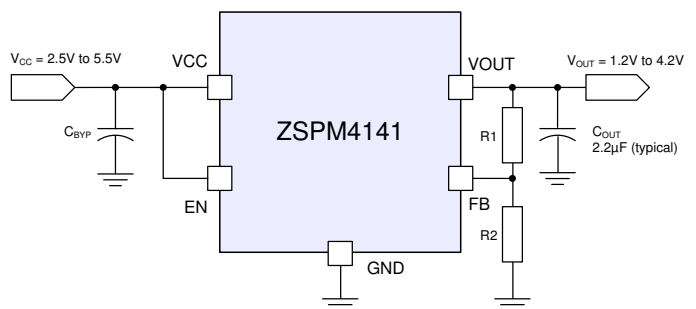

For more information, contact ZMDI via Analog@zmdi.com.

ZSPM4141

Ultra-Low-Power Linear Regulator w/ Minimal Quiescent Current Technology



The Analog Mixed Signal Company



ZSPM4141 Block Diagram

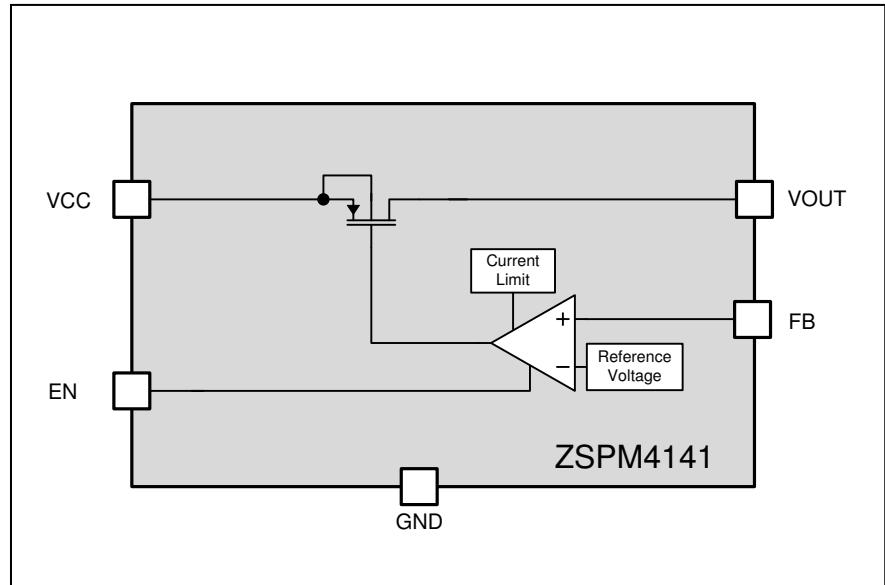

Typical Applications

- Portable Electronics
- Industrial
- Medical
- Smart Cards
- RFID
- Energy-Harvesting Systems

Ordering Information

Ordering Code*	Description	Package
ZSPM4141A1W12	ZSPM4141 Ultra-Low Power Line Regulator —V _{OUT} factory set to 1.2V	8-pin DFN / Reel
ZSPM4141A1W18	ZSPM4141 Ultra-Low Power Line Regulator —V _{OUT} factory set to 1.8V	8-pin DFN / Reel
ZSPM4141A1W25	ZSPM4141 Ultra-Low Power Line Regulator —V _{OUT} factory set to 2.5V	8-pin DFN / Reel
ZSPM4141A1W30	ZSPM4141 Ultra-Low Power Line Regulator —V _{OUT} factory set to 3.0V	8-pin DFN / Reel
ZSPM4141A1W31	ZSPM4141 Ultra-Low Power Line Regulator —V _{OUT} factory set to 3.1V	8-pin DFN / Reel
ZSPM4141A1W33	ZSPM4141 Ultra-Low Power Line Regulator —V _{OUT} factory set to 3.3V	8-pin DFN / Reel
ZSPM4141A1W42	ZSPM4141 Ultra-Low Power Line Regulator —V _{OUT} factory set to 4.2V	8-pin DFN / Reel
ZSPM4141W12KIT	ZSPM4141 Evaluation Kit w/Vout adjusting resistors (default 1.2 Vout)	

* W for 7" reel with 2500 parts. Custom V_{OUT} values are also available: 1.2V to 4.2V (typical) in 100mV increments.

Sales and Further Information

www.zmdi.com

Analog@zmdi.com

Zentrum Mikroelektronik Dresden AG Grenzstrasse 28 01109 Dresden Germany Phone +49.351.8822.7.776 Fax +49.351.8822.8.7776	ZMD America, Inc. 1525 McCarthy Blvd., #212 Milpitas, CA 95035-7453 USA Phone +855.275.9634 (USA) Phone +408.883.6310 Fax +408.883.6358	Zentrum Mikroelektronik Dresden AG, Japan Office 2nd Floor, Shinbashi Tokyu Bldg. 4-21-3, Shinbashi, Minato-ku Tokyo, 105-0004 Japan Phone +81.3.6895.7410 Fax +81.3.6895.7301	ZMD Far East, Ltd. 3F, No. 51, Sec. 2, Keelung Road 11052 Taipei Taiwan Phone +886.2.2377.8189 Fax +886.2.2377.8199	Zentrum Mikroelektronik Dresden AG, Korea Office U-space 1 Building 11th Floor, Unit JA-1102 670 Sampyeong-dong Bundang-gu, Seongnam-si Gyeonggi-do, 463-400 Korea Phone +82.31.950.7679 Fax +82.504.841.3026
---	--	---	--	--

DISCLAIMER: This information applies to a product under development. Its characteristics and specifications are subject to change without notice. Zentrum Mikroelektronik Dresden AG (ZMD AG) assumes no obligation regarding future manufacture unless otherwise agreed to in writing. The information furnished hereby is believed to be true and accurate. However, under no circumstances shall ZMD AG be liable to any customer, licensee, or any other third party for any special, indirect, incidental, or consequential damages of any kind or nature whatsoever arising out of or in any way related to the furnishing, performance, or use of this technical data. ZMD AG hereby expressly disclaims any liability of ZMD AG to any customer, licensee or any other third party, and any such customer, licensee and any other third party hereby waives any liability of ZMD AG for any damages in connection with or arising out of the furnishing, performance or use of this technical data, whether based on contract, warranty, tort (including negligence), strict liability, or otherwise.

ZSPM4141

Ultra-Low-Power Linear Regulator w/ Minimal Quiescent Current Technology



The Analog Mixed Signal Company



Contents

1	ZSPM4141 Characteristics.....	6
1.1.	Absolute Maximum Ratings.....	6
1.2.	Thermal Characteristics.....	6
1.3.	Recommended Operating Conditions	7
1.4.	Electrical Characteristics	7
2	Typical Performance Characteristics	8
3	Description of Circuit	10
4	Application Circuits.....	11
4.1.	Selection of External Components	11
4.1.1.	Output Bypass Capacitor C_{OUT}	11
4.1.2.	Input Bypass Capacitor C_{BYP}	11
4.1.3.	Output Voltage Adjustment Resistors R1 and R2.....	11
4.2.	Typical Application Circuit	12
5	Pin Configuration and Package.....	13
5.1.	ZSPM4141 Package Dimensions and Marking Diagram	13
5.2.	Pin Assignments.....	14
6	Layout and Soldering Requirements	15
6.1.	Recommended Landing Pattern for PCBs	15
6.2.	Multi-Layer PCB Layout.....	16
6.3.	Single-Layer PCB Layout	17
7	Ordering Information	18
8	Related Documents.....	18
9	Document Revision History	19

List of Figures

Figure 2.1	I_{QQ} Performance vs. V_{CC}	8
Figure 2.2	I_{QQ} Performance vs. Temperature	8
Figure 2.3	I_{QQ} Performance vs. Load Current.....	8
Figure 2.4	I_{QQ} Performance vs. Load Current in %.....	8
Figure 2.5	Line Regulation Performance	8
Figure 2.6	V_{OUT} Performance vs. Temperature.....	8
Figure 2.7	Dropout Voltage When V_{OUT} Drops By 3%.....	9
Figure 2.8	Load Regulation Performance	9
Figure 2.9	Load Step Response— $I_{OUT} = 0$ to 30mA	9
Figure 2.10	Load Step Response— $I_{OUT} = 30$ mA to 0	9
Figure 2.11	Load Step Response— $I_{OUT} = 1$ mA to 30mA.....	9
Figure 2.12	Line Step Response	9
Figure 2.13	Output Enable Timing	10
Figure 3.1	ZSPM4141 Block Diagram	10

ZSPM4141

Ultra-Low-Power Linear Regulator w/ Minimal Quiescent Current Technology

ZMDI[®]

The Analog Mixed Signal Company



Figure 4.1	Basic ZSPM4141 Application Circuit—Fixed Output.....	12
Figure 4.2	ZSPM4141A1W12 Application Circuit—Variable Output	12
Figure 5.1	ZSPM4141 Package Drawing.....	13
Figure 5.2	ZSPM4141 Pin Assignments (top view)	14
Figure 6.1	Recommended Landing Pattern for 8-Pin DFN.....	15
Figure 6.2	Package and PCB Land Configuration for Multi-Layer PCB	16
Figure 6.3	JEDEC Standard FR4 Multi-Layer Board – Cross-Sectional View.....	16
Figure 6.4	Conducting Heat Away from the Die using an Exposed Pad Package	17
Figure 6.5	Application Using a Single-Layer PCB	17

List of Tables

Table 1.1	Absolute Maximum Ratings	6
Table 1.2	Thermal Characteristics for 8-pin DFN (2x2) Package.....	6
Table 1.3	Recommended Operating Conditions	7
Table 1.4	Electrical Characteristics	7
Table 4.1	Output Voltage Adjustment Resistors and Resulting I_{OQ} Increase	11
Table 5.1	Pin Description, 8-Pin DFN (2mmx2mm)	14

ZSPM4141

Ultra-Low-Power Linear Regulator w/ Minimal Quiescent Current Technology

ZMDI[®]

The Analog Mixed Signal Company



1 ZSPM4141 Characteristics

Important: Stresses beyond those listed under “Absolute Maximum Ratings” (section 1.1) may cause permanent damage to the device. These are stress ratings only. Functional operation of the device at these or any other conditions beyond those indicated under “Recommended Operating Conditions” (section 1.3) is not implied. Exposure to absolute–maximum–rated conditions for extended periods could affect device reliability.

1.1. Absolute Maximum Ratings

Over operating free–air temperature range unless otherwise noted. All voltage values are with respect to network ground terminal.

Table 1.1 Absolute Maximum Ratings

Parameter	Symbol	Value	Unit
Maximum input/output on VCC, VOUT, EN, and FB pins		-0.3 to 6.0	V
Electrostatic Discharge – Human Body Model, according to the respective JESD22 JEDEC standard		2	kV
Electrostatic Discharge – Charged Device Model, according to the respective JESD22-C101 JEDEC standard		500	V
Operating Junction Temperature Range	T_J	-20 to 85	°C
Storage Temperature Range	T_{stg}	-65 to 150	°C
Lead Temperature (soldering, 10 seconds)		260	°C

1.2. Thermal Characteristics

Table 1.2 Thermal Characteristics for 8-pin DFN (2x2) Package

θ_{JA} (°C/W) ¹⁾	θ_{JC} (°C/W) ²⁾
73.1	10.7
1) This assumes a FR4 board only. 2) This assumes a 1oz. copper JEDEC standard board with thermal vias. See section 6.1 for more information.	

ZSPM4141

Ultra-Low-Power Linear Regulator w/ Minimal Quiescent Current Technology



The Analog Mixed Signal Company



1.3. Recommended Operating Conditions

Table 1.3 Recommended Operating Conditions

Parameter	Symbol	Min	Typ	Max	Unit
Unregulated Supply Input at VCC pin	V _{CC}	2.5		5.5	V
Enable Input (EN pin)	V _{EN}	0		5.0	V
Typical Regulated Supply Output Voltage	V _{OUT}	1.2		4.2	V
Operating Ambient Temperature ¹⁾	T _A	-20		55	°C
Operating Junction Temperature	T _J	-20		85	°C

1) Operating ambient temperature is only intended as a guideline. The operating junction temperature requirements must not be exceeded.

1.4. Electrical Characteristics

Electrical characteristics, V_{CC} = 2.5V to 5V (unless otherwise noted). Minimum and maximum characteristics tested at T_J = 25°C.

Table 1.4 Electrical Characteristics

Parameter	Symbol	Condition	Min	Typ	Max	Unit
Input Supply Voltage	V _{CC}		2.5		5.5	V
Input Low Logic Level	V _{IL} EN				0.3*V _{CC}	V
Input High Logic Level	V _{IH} EN		0.7*V _{CC}			V
Output Bypass Capacitor	C _{OUT}		1	2.2	4.7	μF
Input Bypass Capacitor	C _{BYP}			0.1		μF
Quiescent Current:	I _{QQ}	V _{CC} = 4.2V, I _{OUT} =0		20		nA
Quiescent Current: Power-Down Mode	I _{QQpd}	I _{OUT} =0, EN = 0		100		pA
Operating Current	I _{OP-GND}	V _{CC} = 2.5V, I _{OUT} = 200mA		200		μA
		V _{CC} = 3.3V, I _{OUT} = 200mA		200		μA
		V _{CC} = 5.5V, I _{OUT} = 200mA		200		μA
Load Capability	I _{OUT}		0		200	mA
DC Line Regulation	V _{LINE}	V _{CC} = 2.5V to 5V, V _{OUT} = 1.8V, I _{OUT} = 50mA		0.5	1	%
DC Load Regulation	V _{LOAD}	V _{CC} = 4.2V, I _{OUT} = 0.02mA to 200mA, V _{OUT} = V _{OUT,nominal} +300mV		1	2	%
Current Limit	I _{LIMIT}	I _{OUT} measured at V _{OUT} = 0.9*V _{OUT,nominal}		250		mA

ZSPM4141

Ultra-Low-Power Linear Regulator w/ Minimal Quiescent Current Technology



The Analog Mixed Signal Company



2 Typical Performance Characteristics

$C_{IN} = 10\mu F$ and $T = 25^\circ C$ (unless otherwise noted)

Figure 2.1 I_{QQ} Performance vs. V_{CC}

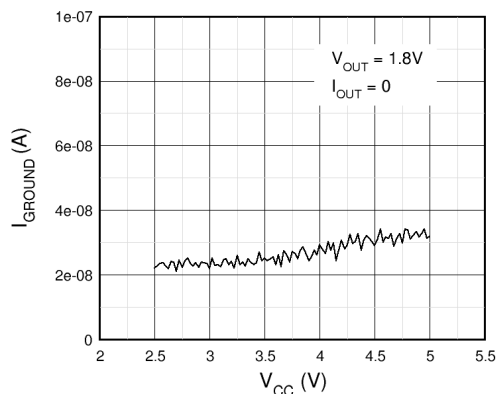

Figure 2.2 I_{QQ} Performance vs. Temperature

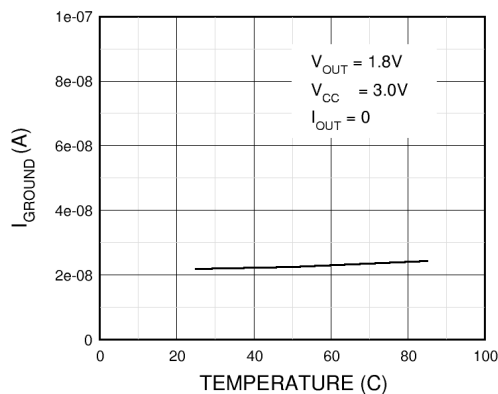

Figure 2.3 I_{QQ} Performance vs. Load Current

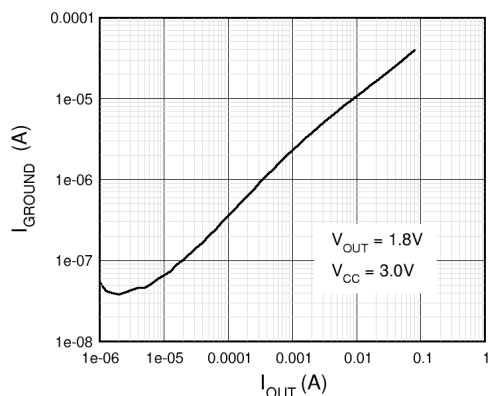

Figure 2.4 I_{QQ} Performance vs. Load Current in %

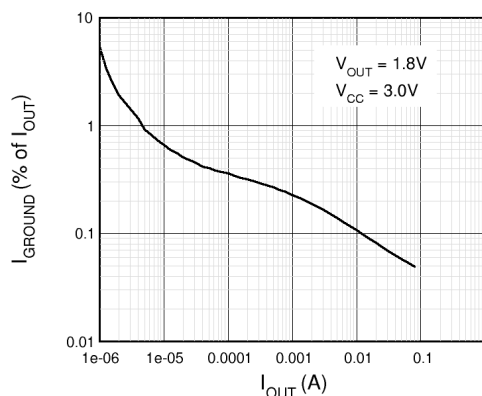

Figure 2.5 Line Regulation Performance

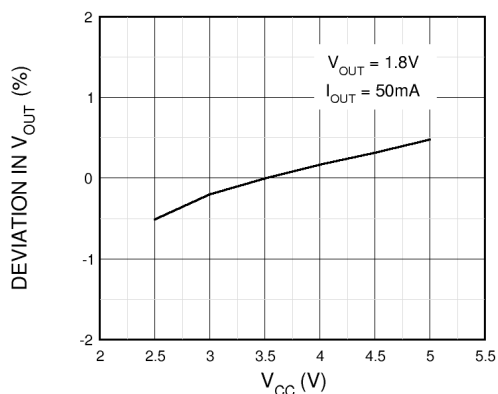
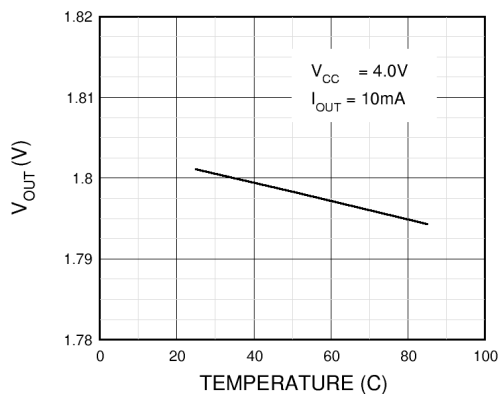

Figure 2.6 V_{OUT} Performance vs. Temperature



ZSPM4141

Ultra-Low-Power Linear Regulator w/ Minimal Quiescent Current Technology



The Analog Mixed Signal Company



Figure 2.7 Dropout Voltage When V_{OUT} Drops By 3%

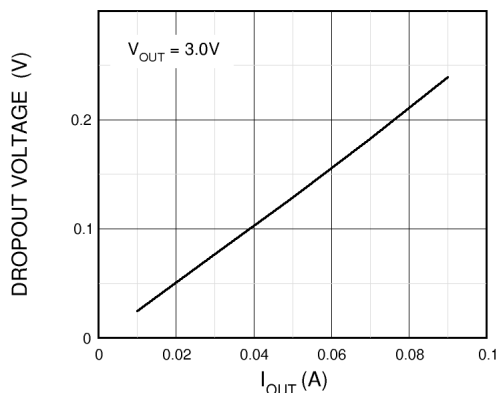

Note: Dropout voltage is defined as $V_{CC} - V_{OUT}$ when V_{OUT} drops 3% below its nominal value.

Figure 2.8 Load Regulation Performance

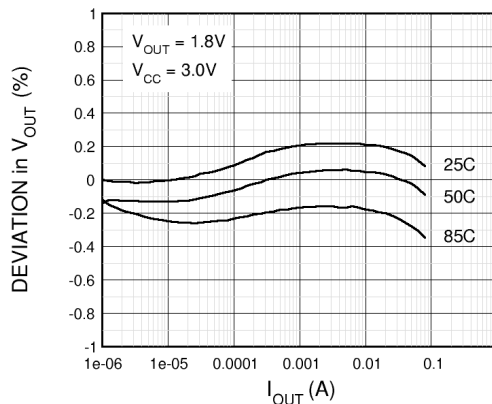

Figure 2.9 Load Step Response— $I_{OUT} = 0$ to 30mA

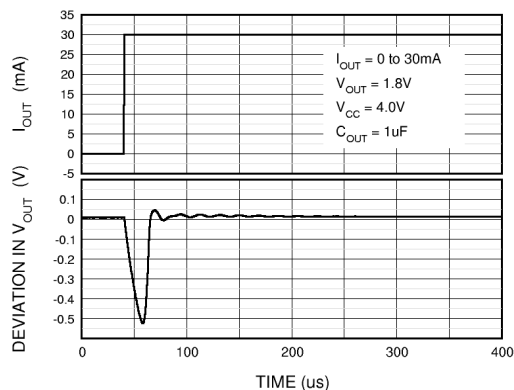

Figure 2.10 Load Step Response— $I_{OUT} = 30mA$ to 0

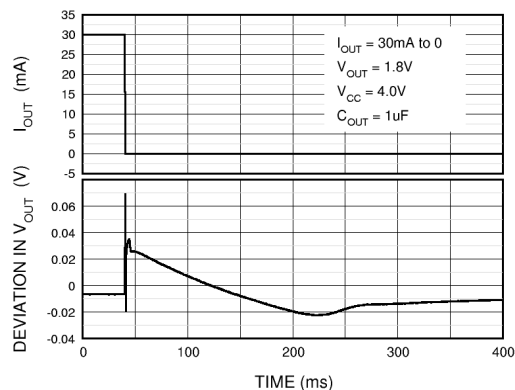

Figure 2.11 Load Step Response— $I_{OUT} = 1mA$ to 30mA

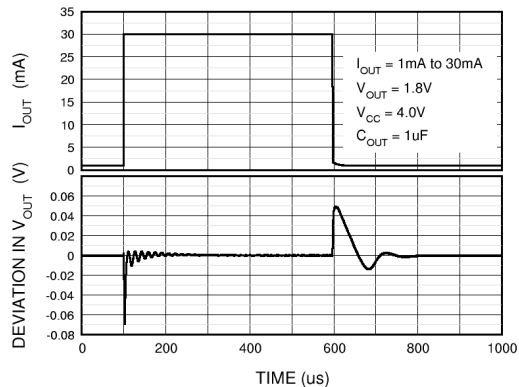
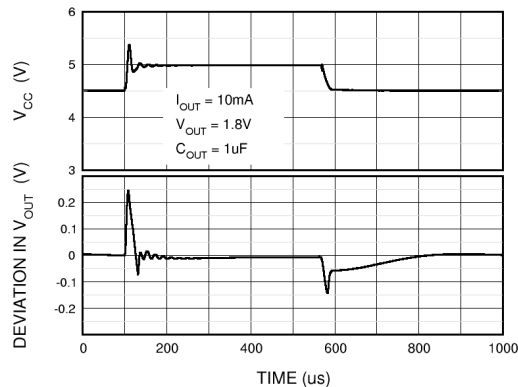

Figure 2.12 Line Step Response



ZSPM4141

Ultra-Low-Power Linear Regulator w/ Minimal Quiescent Current Technology

ZMDI[®]

The Analog Mixed Signal Company



Figure 2.13 Output Enable Timing

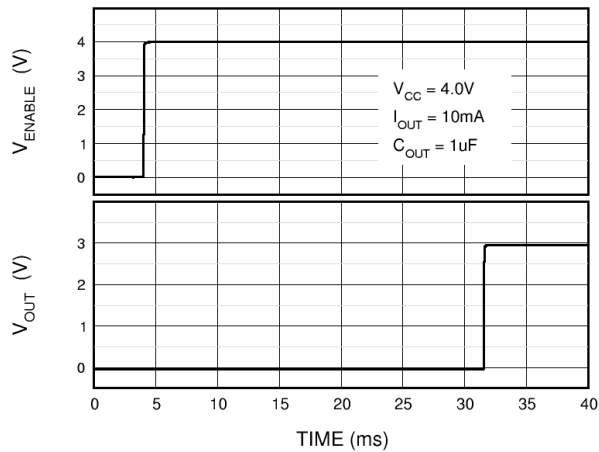

3 Description of Circuit

The ZSPM4141 is an ultra-low-power linear regulator optimized for minimal quiescent current losses via advanced, proprietary technology. It draws low nA-level quiescent current for light loads, yet it can regulate current loads as high as 200mA. The linear regulated output voltage is factory-configured to an option from 1.2V to 4.2V in 100mV steps. The ZSPM4141 also provides over-current protection (see Table 1.4).

Figure 3.1 ZSPM4141 Block Diagram

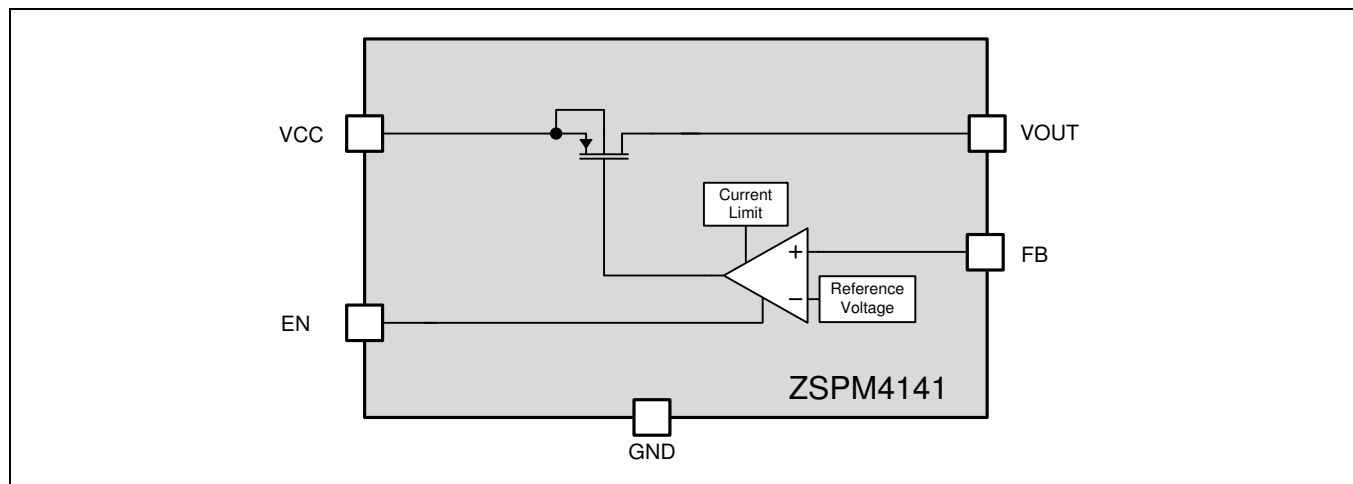



4 Application Circuits

4.1 Selection of External Components

4.1.1 Output Bypass Capacitor C_{OUT}

Connect a bypass capacitor (C_{OUT}) from the VOUT pin to ground. The typical value for C_{OUT} is 2.2 μ F. See Table 1.4 for further specifications.

4.1.2 Input Bypass Capacitor C_{BYP}

Connect a bypass capacitor (C_{BYP}) from the VCC pin to ground. The typical value for C_{OUT} is 0.1 μ F.

4.1.3 Output Voltage Adjustment Resistors R1 and R2

The ZSPM4141W12KIT includes a set of output adjustment resistors for R1 and R2 shown in the variable output circuit on page 2. Refer to Table 4.1 for the effect of different combinations of the resistors on the output voltage and the resulting increase in I_{QQ} current.

Table 4.1 Output Voltage Adjustment Resistors and Resulting I_{QQ} Increase

Vout	R1 (+/-0.1%)	R2 (+/-1%)	I_{QQ} increase
1.2	0		
1.5	1.00M Ω	4.02M Ω	0.30 μ A
1.8	1.00M Ω	2M Ω	0.60 μ A
3	1.00M Ω	665k Ω	1.80 μ A
3.3	1.00M Ω	576k Ω	2.10 μ A
4.2	1.00M Ω	402k Ω	3.00 μ A

ZSPM4141

Ultra-Low-Power Linear Regulator w/ Minimal Quiescent Current Technology



The Analog Mixed Signal Company



4.2. Typical Application Circuit

Figure 4.1 Basic ZSPM4141 Application Circuit—Fixed Output

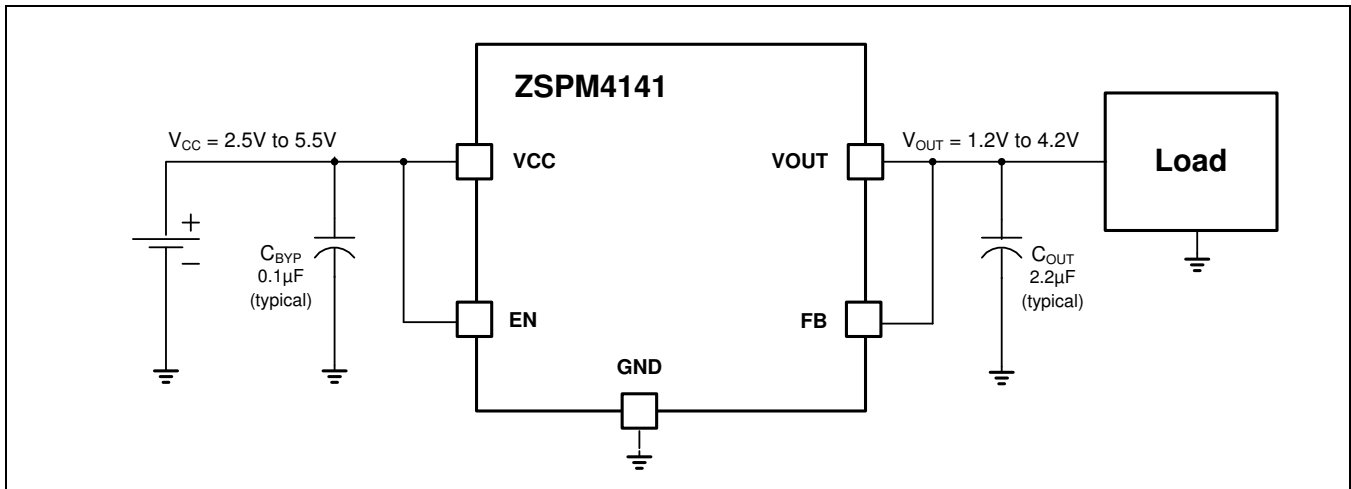
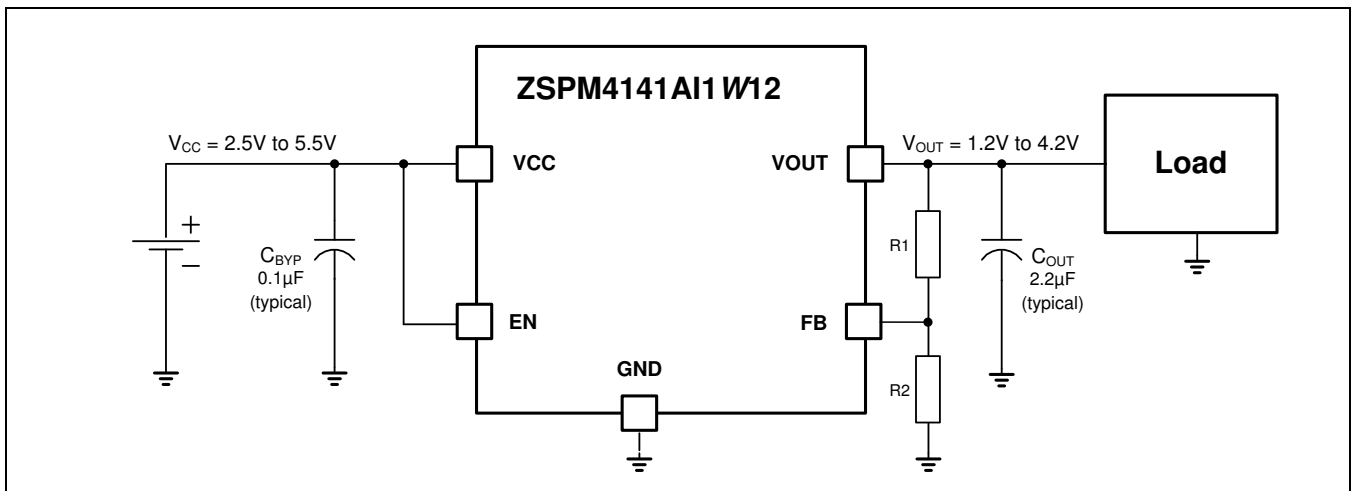

Figure 4.2 ZSPM4141A1W12 Application Circuit—Variable Output



ZSPM4141

Ultra-Low-Power Linear Regulator w/ Minimal Quiescent Current Technology

ZMDI[®]

The Analog Mixed Signal Company



5 Pin Configuration and Package

5.1. ZSPM4141 Package Dimensions and Marking Diagram

Figure 5.1 ZSPM4141 Package Drawing

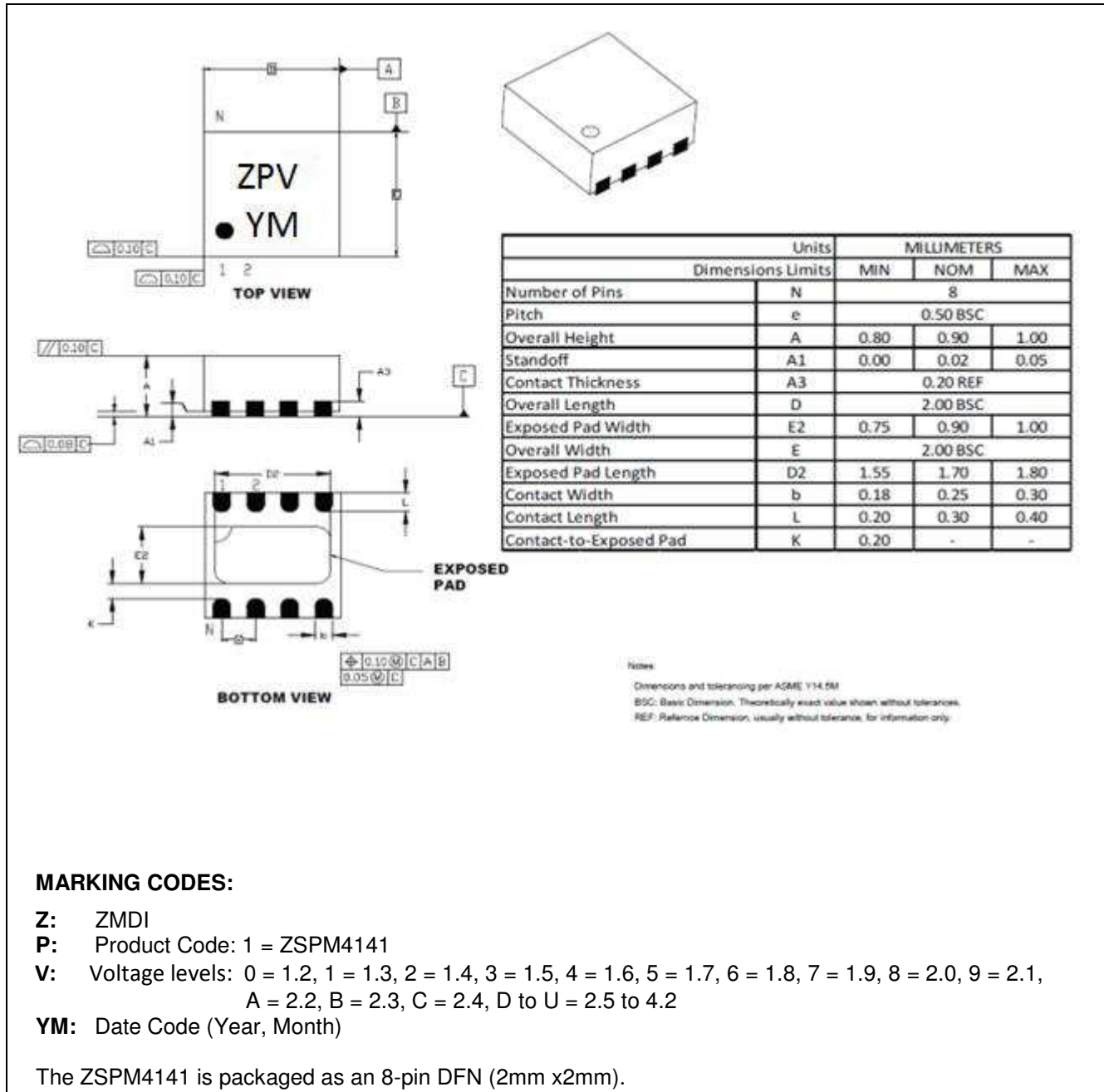

ZSPM4141

Ultra-Low-Power Linear Regulator w/ Minimal Quiescent Current Technology



The Analog Mixed Signal Company



5.2. Pin Assignments

Figure 5.2 ZSPM4141 Pin Assignments (top view)

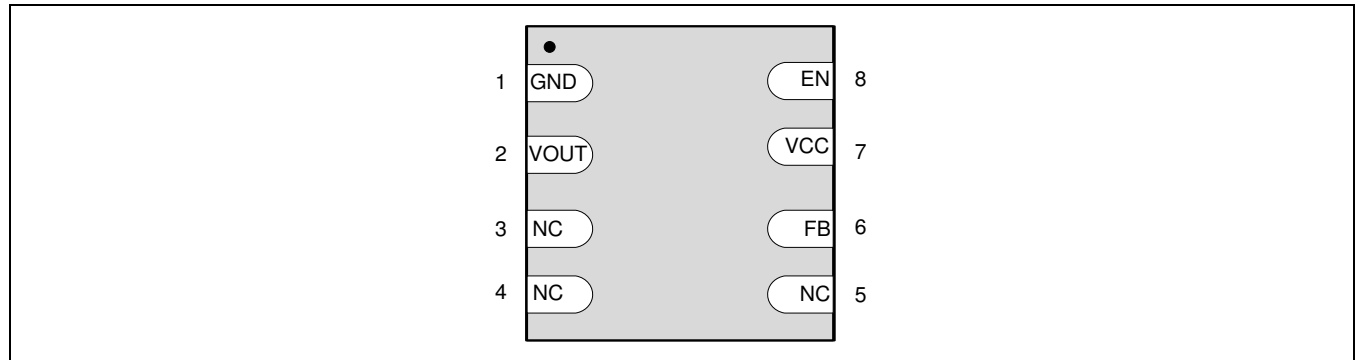

Table 5.1 Pin Description, 8-Pin DFN (2mmx2mm)

Pin #	Name	Function	Description
1	GND	Ground	GND
2	VOUT	Output	Regulated Output Voltage
3	NC		No Connection (connect to GND or float)
4	NC		No Connection (connect to GND or float)
5	NC		No Connection (connect to GND or float)
6	FB	Input	Feedback Input
7	VCC	Supply	Input Power
8	EN	Input	Enable Input

ZSPM4141

Ultra-Low-Power Linear Regulator w/ Minimal Quiescent Current Technology

ZMDI[®]

The Analog Mixed Signal Company



6 Layout and Soldering Requirements

To maximize the efficiency of this package for applications on a single layer or multi-layer printed circuit board (PCB), certain guidelines must be followed when laying out this part on the PCB.

6.1. Recommended Landing Pattern for PCBs

Figure 6.1 Recommended Landing Pattern for 8-Pin DFN

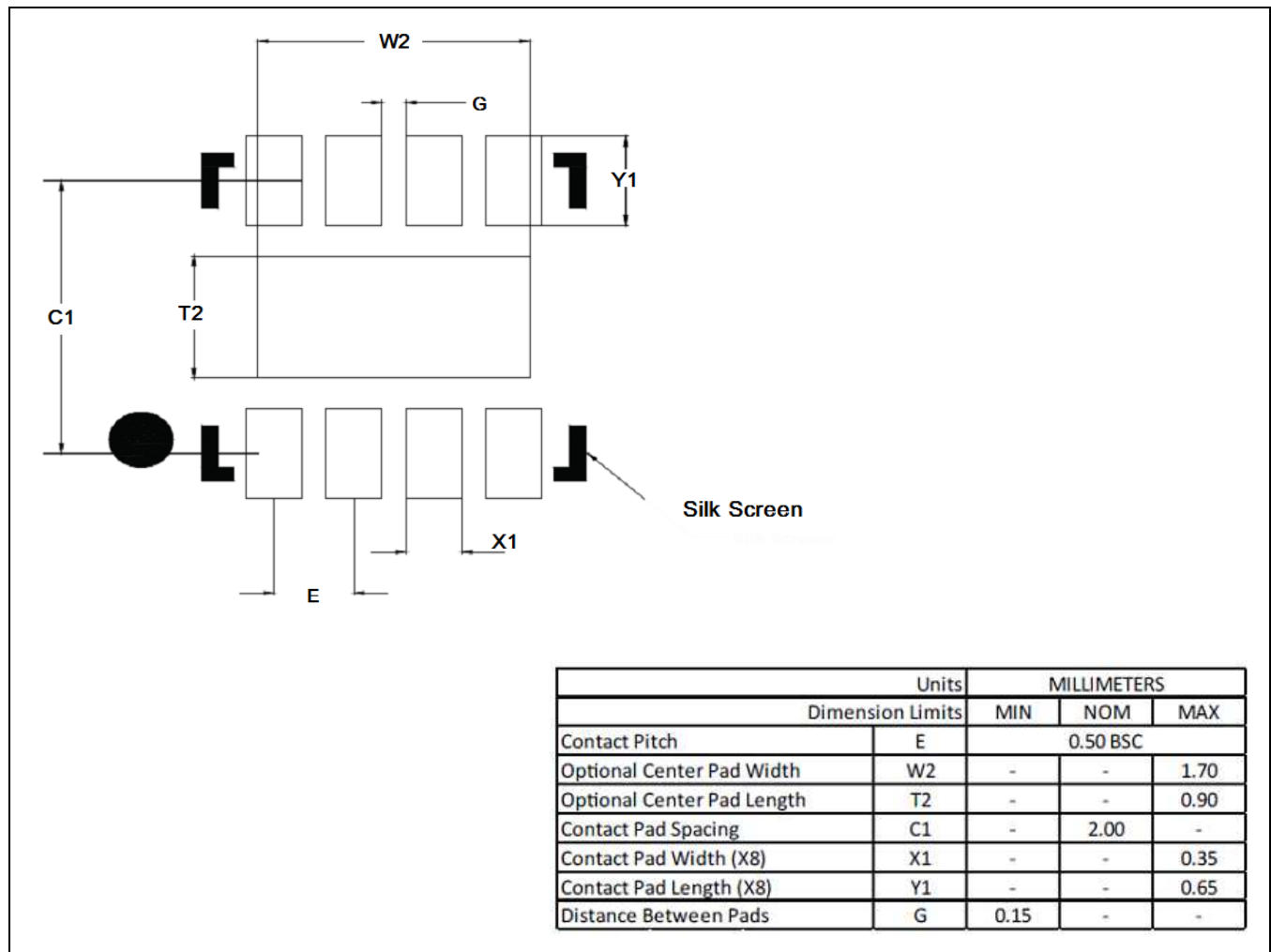

ZSPM4141

Ultra-Low-Power Linear Regulator w/ Minimal Quiescent Current Technology



The Analog Mixed Signal Company



6.2. Multi-Layer PCB Layout

The following are guidelines for mounting the exposed pad ZSPM4141 on a multi-layer PCB with ground a plane. In a multi-layer board application, the thermal vias are the primary method of heat transfer from the package thermal pad to the internal ground plane. The efficiency of this method depends on several factors, including die area, number of thermal vias, and thickness of copper, etc.

Figure 6.2 Package and PCB Land Configuration for Multi-Layer PCB

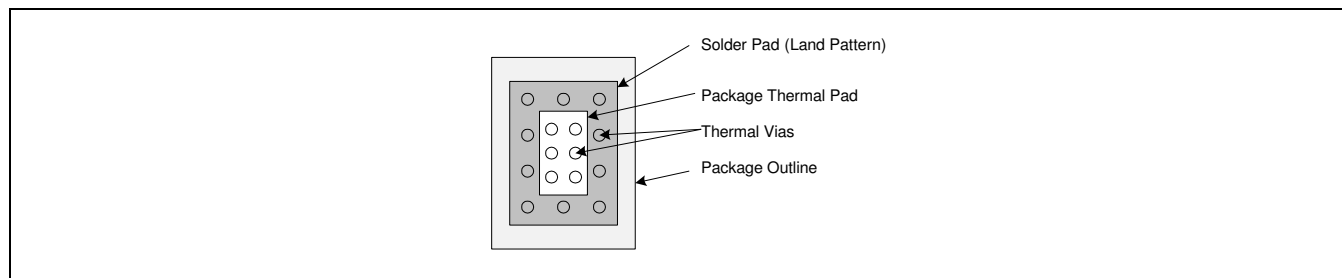

Figure 6.3 JEDEC Standard FR4 Multi-Layer Board – Cross-Sectional View

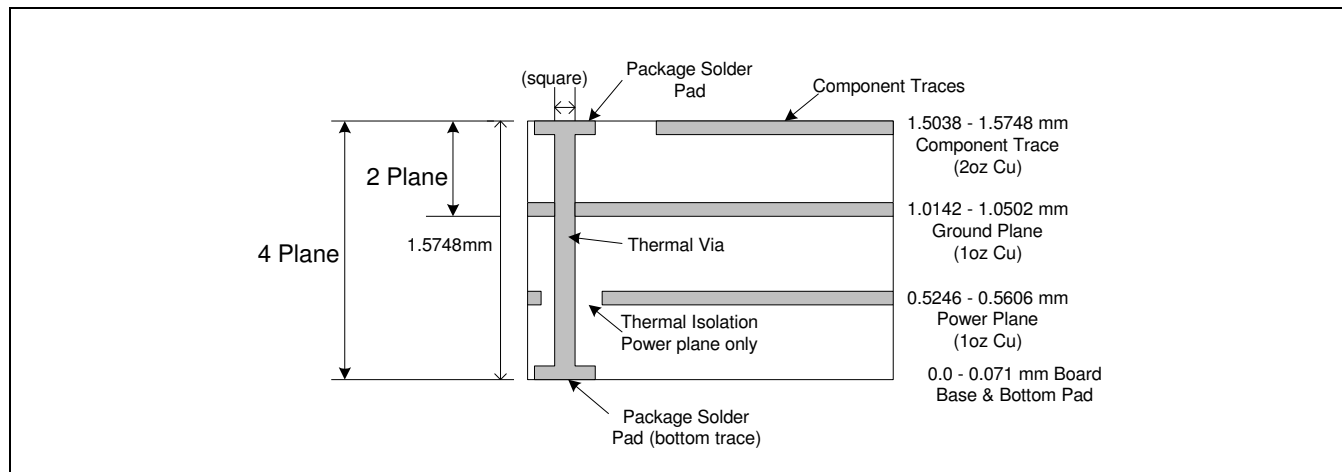
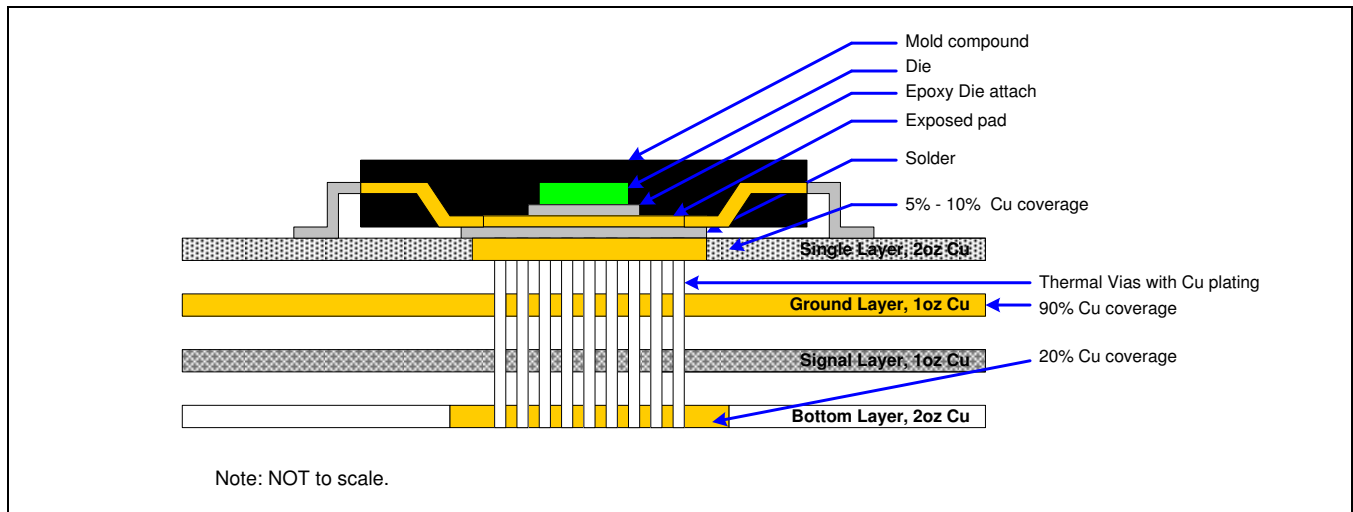

Figure 6.4 is a representation of how the heat can be conducted away from the die using an exposed pad package. Each application will have different requirements and limitations, and therefore the user should use sufficient copper to dissipate the power in the system. The output current rating for the linear regulators might need to be de-rated for ambient temperatures above 85°C. The de-rated value will depend on calculated worst-case power dissipation and the thermal management implementation in the application.



Figure 6.4 Conducting Heat Away from the Die using an Exposed Pad Package



6.3. Single-Layer PCB Layout

Layout recommendation for a single-layer PCB: utilize as much copper area for power management as possible. In a single-layer board application, the thermal pad is attached to a heat spreader (copper areas) by using a low thermal impedance attachment method (solder paste or thermal conductive epoxy).

In both of the methods mentioned above, it is advisable to use as much copper trace as possible to dissipate the heat.

Figure 6.5 Application Using a Single-Layer PCB

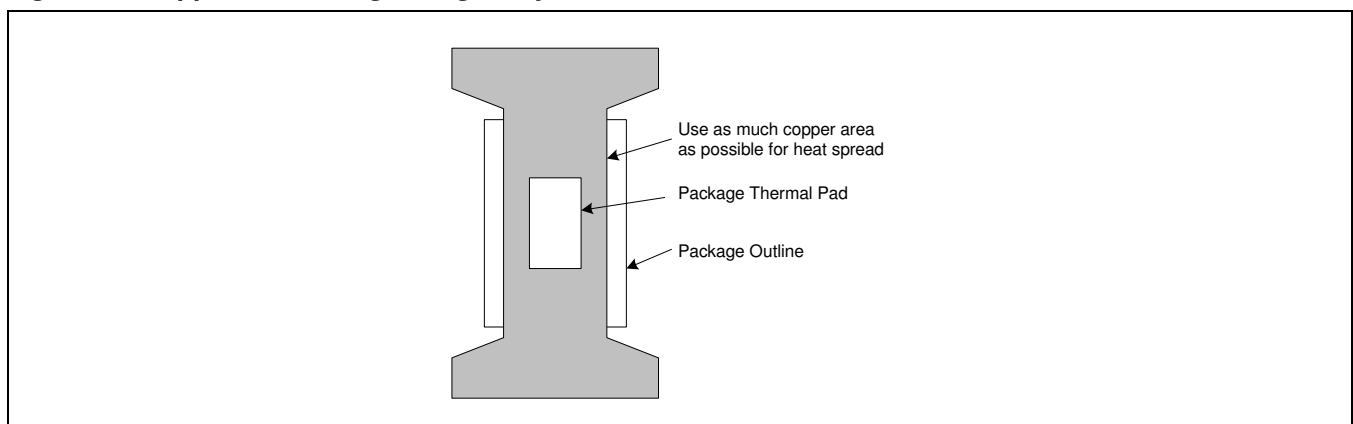

Important: If the attachment method is NOT implemented correctly, the functionality of the product is not guaranteed. Power dissipation capability will be adversely affected if the device is incorrectly mounted onto the circuit board.

ZSPM4141

Ultra-Low-Power Linear Regulator w/ Minimal Quiescent Current Technology



The Analog Mixed Signal Company



7 Ordering Information

Ordering Code*	Description	Package
ZSPM4141A11W12	ZSPM4141 Ultra-Low Power Line Regulator — V_{OUT} factory set to 1.2V	8-pin DFN / Reel
ZSPM4141A11W18	ZSPM4141 Ultra-Low Power Line Regulator — V_{OUT} factory set to 1.8V	8-pin DFN / Reel
ZSPM4141A11W25	ZSPM4141 Ultra-Low Power Line Regulator — V_{OUT} factory set to 2.5V	8-pin DFN / Reel
ZSPM4141A11W30	ZSPM4141 Ultra-Low Power Line Regulator — V_{OUT} factory set to 3.0V	8-pin DFN / Reel
ZSPM4141A11W31	ZSPM4141 Ultra-Low Power Line Regulator — V_{OUT} factory set to 3.1V	8-pin DFN / Reel
ZSPM4141A11W33	ZSPM4141 Ultra-Low Power Line Regulator — V_{OUT} factory set to 3.3V	8-pin DFN / Reel
ZSPM4141A11W42	ZSPM4141 Ultra-Low Power Line Regulator — V_{OUT} factory set to 4.2V	8-pin DFN / Reel
ZSPM4141W12KIT	ZSPM4141 Evaluation Kit w/ V_{out} adjusting resistors (default 1.2 V_{out})	

Custom V_{OUT} values are also available: 1.2V to 4.2V (typical) in 100mV increments.

8 Related Documents

Document	File Name
ZSPM4141 Feature Sheet	ZSPM4141_Feature_Sheet_revX_xy.pdf
ZSPM4141 Evaluation Kit Description	ZSPM4141_Eval_Kit_Description_revX_xy.pdf
ZSPM4141 Application Note—Low Power Battery Control and Voltage Regulator Solutions for Remote Sensor Networks	ZSPM4141_App_Note_LP-Batt-Contr-VReg-Remote-Sensor-Net_X_xy.pdf

Note: X_xy refers to the current revision of the document.

Visit ZMDI's website www.zmdi.com or contact your nearest sales office for the latest version of these documents.

ZSPM4141

Ultra-Low-Power Linear Regulator w/ Minimal Quiescent Current Technology

ZMDI[®]

The Analog Mixed Signal Company



9 Document Revision History

Revision	Date	Description
1.00	August 6, 2012	First release.
2.00	January 11, 2013	Addition of variable output illustration and Table 4.1. Update for ordering codes and contact information. Update for "Electrostatic Discharge" specification in Table 1.1.

Sales and Further Information

www.zmdi.com

Analog@zmdi.com

Zentrum Mikroelektronik Dresden AG Grenzstrasse 28 01109 Dresden Germany Phone +49.351.8822.7.776 Fax +49.351.8822.8.7776	ZMD America, Inc. 1525 McCarthy Blvd., #212 Milpitas, CA 95035-7453 USA Phone +855.275.9634 (USA) Phone +408.883.6310 Fax +408.883.6358	Zentrum Mikroelektronik Dresden AG, Japan Office 2nd Floor, Shinbashi Tokyu Bldg. 4-21-3, Shinbashi, Minato-ku Tokyo, 105-0004 Japan Phone +81.3.6895.7410 Fax +81.3.6895.7301	ZMD Far East, Ltd. 3F, No. 51, Sec. 2, Keelung Road 11052 Taipei Taiwan Phone +886.2.2377.8189 Fax +886.2.2377.8199	Zentrum Mikroelektronik Dresden AG, Korea Office U-space 1 Building 11th Floor, Unit JA-1102 670 Sampyeong-dong Bundang-gu, Seongnam-si Gyeonggi-do, 463-400 Korea Phone +82.31.950.7679 Fax +82.504.841.3026
---	--	---	--	--

DISCLAIMER: This information applies to a product under development. Its characteristics and specifications are subject to change without notice. Zentrum Mikroelektronik Dresden AG (ZMD AG) assumes no obligation regarding future manufacture unless otherwise agreed to in writing. The information furnished hereby is believed to be true and accurate. However, under no circumstances shall ZMD AG be liable to any customer, licensee, or any other third party for any special, indirect, incidental, or consequential damages of any kind or nature whatsoever arising out of or in any way related to the furnishing, performance, or use of this technical data. ZMD AG hereby expressly disclaims any liability of ZMD AG to any customer, licensee or any other third party, and any such customer, licensee and any other third party hereby waives any liability of ZMD AG for any damages in connection with or arising out of the furnishing, performance or use of this technical data, whether based on contract, warranty, tort (including negligence), strict liability, or otherwise.

Data Sheet

January 11, 2013

© 2013 Zentrum Mikroelektronik Dresden AG — Rev. 2.00

All rights reserved. The material contained herein may not be reproduced, adapted, merged, translated, stored, or used without the prior written consent of the copyright owner. The information furnished in this publication is subject to changes without notice.

19 of 19