

## SY05-HLPL

Date: May 20, 2002



- **INTRODUCTION**

The SY05-HLPL is a high frequency clock that has been designed to be use at high speed Line Interface Cards in telecommunication products mainly related to STN-n or OC-n.

- **FEATURES**

- ✓ A high frequency clock intended to be used at line cards for OC3 and OC12 (STM3 and STM12).
- ✓ Along with SY0001 or SY05-HLPL provides complete timing solution.
- ✓ Provides very low jitter output signal from **51.84MHz to 800MHz**
- ✓ Performs hitless switching between two reference signals
- ✓ Supports four timing modes: (1) Free-run, (2) Locked to Reference 1 (3) Locked to Reference 2, and (4) Loop-back timing.
- ✓ Accepts reference inputs from two clock sources from **8kHz to 77.76MHz**
- ✓ Manual or Automatic selection between operating modes.
- ✓ Alarm and status signals.
- ✓ Complies with ITU-T Recommendations G.813, ETSI-ETS 300 462-4 and Bellcore GR-1244-CORE for Stratum 3 and 3E applications.
- ✓ Small dimensions of 1.8 x 1.8 x 0.50 inch.

- **APPLICATION**

The SY05-HLPL high frequency clock can be used in ATM, SDH, PDH, and SONET networks devices. It is designed for manufacturers of network equipment, especially Access Switches, Core Switches, Cross Connects, Digital Multiplexers-Exchangers, and SDH/SONET equipment. The SY05-HLPL is a timing solution for Line Interface Cards.

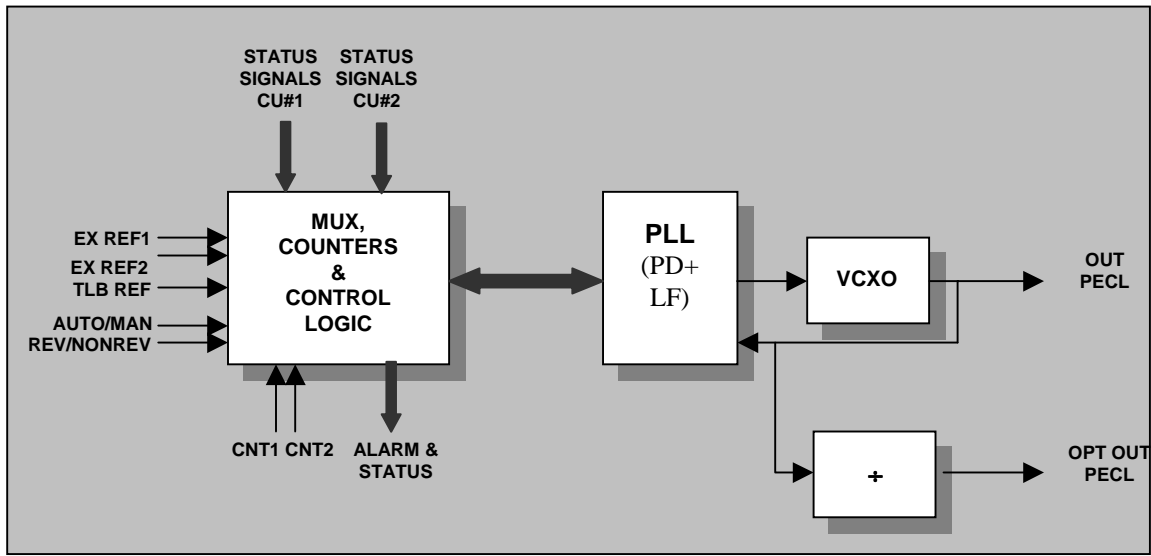

Figure 1. - The functional block diagram of SY05-HLPL

### • DESCRIPTION

The SY05-HLPL synchronization module is a high frequency PLL that performs hitless switching plus additional features necessary for timing at high-speed Line Interface Cards. The functional block diagram is shown in figure 1. The SY05-HLPL receives two reference signals, usually 19.44MHz and using PLL synthesizer generates a high frequency signal necessary for transceivers or framers. The PLL that is complemented by high-speed logic that provide processing, switching between the timing modes, alarm and status messages and etc. A high quality VCXO provides very low jitter at the output. The additional output is provided using a divider.

The module supports two operating modes: AUTO mode is the mode where all switching are done automatically and MANUAL mode is where unit will switch according to the two external control pins CON1 and CON2.

| CON1 | CON2 | Operational mode    |
|------|------|---------------------|
| 0    | 0    | Free-run (Unlocked) |
| 1    | 0    | Locked to EX REF 1  |
| 0    | 1    | Locked to EX REF 2  |
| 1    | 1    | Locked to TLB REF   |

The module operates in the following four timing modes: 1) Free-run, 2) Locked to EX REF1, 3) Locked to EX REF2 and 4) Locked to TBL REF. Free-run it a mode the unit is unlocked to either of the inputs. The accuracy of the output frequencies in this mode is equal to the accuracy of free running VCXO. Locked to EX REF 1 is the mode where the output of the module is phase locked to input reference 1. Locked to EX REF 2 is the mode where the output of the module is phase locked to input reference 2, Locked to TBL REF is the mode where is the output of the module is phase locked to the signal used in Time Loop-back operation.

• **SPECIFICATIONS**

|                              |  |   |   |
|------------------------------|--|---|---|
| General Specifications       | Mechanical   | 1.82" (D) x 1.82" (W) x 0.425" (H)<br>1.95" (D) x 1.95" (W) x 0.45" (H)             | Metal Box<br>Module on PCB                |
|                              | Power Supply<br>Current Supply<br>Operating Temperature<br>Storage Temperature<br>Humidity<br>Internal Oscillators | +3.3VDC<br>TBD<br>-20°C to 70°C<br>-40° to 85°C<br>5% to 95% non-condensing<br>VCXO | SAW oscillators                           |
| Input Signals                | Number of Inputs   | 2   |   |
|                              | Input reference frequency<br>Signal Level  | 8KHz~19.44MHz<br>HCMOS/TTL Compatible   |   |
| Output Signal                | Number of Outputs  | 2   |   |
|                              | Output 1<br>Output 2   | 155.52MHz<br>Out1 divide by 2/4 or 8  | 622.08MHz optional                        |
|                              | Signal Level   | LVPECL  | 50+/-5%                                   |
| Signal Quality Performance   | Jitter Tolerance   |   | Bell-core: GR-1244-core 4.2, ITU-T: G.812 |
|                              | Phase Transient Tolerance  |   | Bell-core: GR-1244-core 4.4               |
|                              | Wander Tolerance   |   | Bell-core: GR-1244-core 4.3, ITU-T: G.812 |
|                              | Jitter Generation and Transfer   |   | Bell-core: GR-1244-core 5.5, ITU-T: G.812 |
| Frequency Output Performance | Free run accuracy  | ±20ppm  |   |
|                              | Pull-In Range  | ±50ppm  |   |
|                              | MTIE   |   | Bell-core: GR-1244-core 4.2, ITU-T: G.812 |
|                              | TDEV   |   | Bell-core: GR-1244-core 4.2, ITU-T: G.812 |

**• PIN ASSIGNMENT**

On the picture below it is shown the pin-out for the SY05-HLPL. For other pin-out requirement please contact the Raltron.

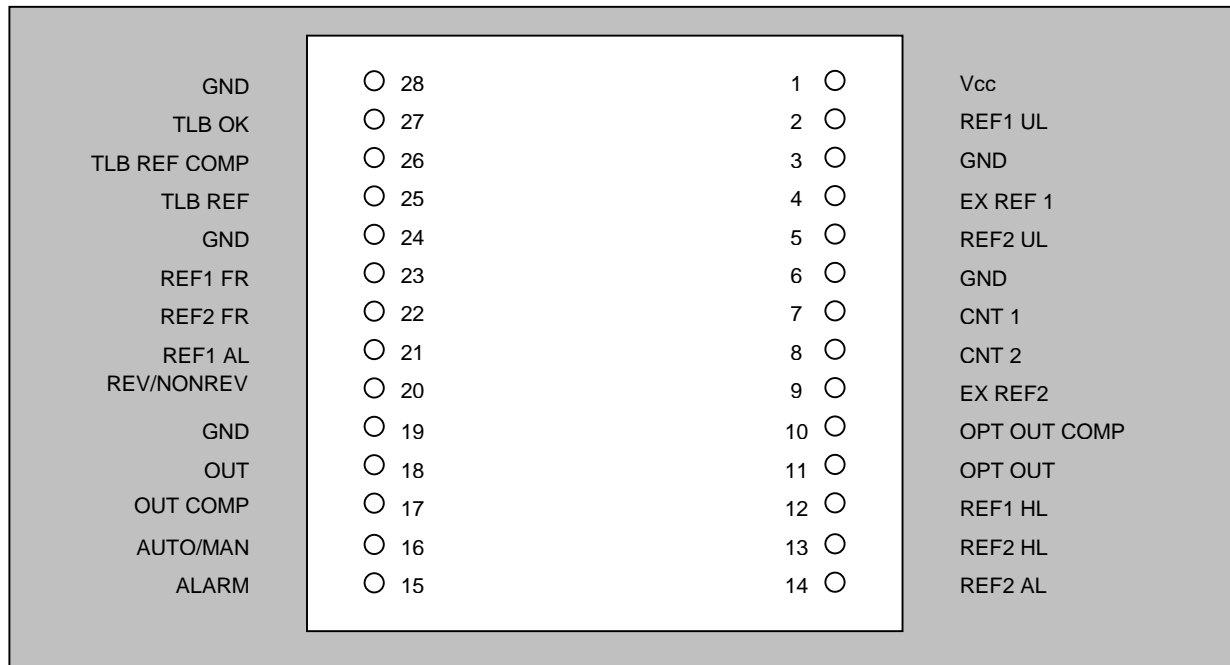

Figure 3 – Bottom view



# SYNCHRONOUS EQUIPMENT DUAL OUTPUT HITLESS SWITCHING - SY05-HLPL

| Pin # | Name         | Description  | Signal Technology           | VL        |                   |                   | VH/ DC Voltage    |                 |                   |
|-------|--------------|--|-----------------------------|-----------|-------------------|-------------------|-------------------|-----------------|-------------------|
|       |              |  |                             | Min       | Typ               | Max               | Min               | Typ             | Max               |
| 1     | +Vcc         | Positive Voltage Supply  | DC                          | -----     | -----             | -----             | 4.75**<br>(3.135) | 5.0**<br>(3.3)  | 5.25**<br>(3.465) |
| 2     | REF1 UL      | Reference 1 Unlocked Input -> the signal PLL UNLOCK comes from Clock Unit 1                              | DC                          | 0         | 0.25 **<br>(0.15) | 0.5**<br>(0.3)    | 4.5**<br>(2.97)   | 5.0**<br>(3.3)  | 5.25**<br>(3.465) |
| 3     | GND          | Ground   | -----                       | -----     | -----             | -----             | -----             | -----           |                   |
| 4     | EX REF 1     | External Reference 1 Input -> the input signal from reference 1  | HCMOS<br>(3.3<br>Tolerable) | 0         | 0.5**<br>(0.3)    | 4.5**             | (2.97)            | -----           | -----             |
| 5     | REF2 UL      | Reference 2 Unlocked Input -> the signal PLL UNLOCK comes from Clock Unit 2                              | DC                          | 0         | 0.25 **<br>(0.15) | 0.5**<br>(0.3)    | 4.5**<br>(2.97)   | 5.0**<br>(3.3)  | 5.25**<br>(3.465) |
| 6     | GND          | Ground   | -----                       | -----     | -----             | -----             | -----             | -----           |                   |
| 7     | CNT 2        | Control Input 2 -> the external input for selecting mode of the unit – see table.                        | DC                          | 0         | 0.25 (0.15)       | 0.5<br>(0.3)      | 4.5<br>(2.97)     | 5.0<br>(3.3)    | 5.25<br>(3.465)   |
| 8     | CNT 1        | Control Input 1 -> the external input for selecting mode of the unit – see table.                        | DC                          | 0         | 0.25 **<br>(0.15) | 0.5**<br>(0.3)    | 4.5**<br>(2.97)   | 5.0**<br>(3.3)  | 5.25**<br>(3.465) |
| 9     | EX REF 2     | External Reference 2 Input -> the input signal from reference 2  | HCMOS<br>(3.3<br>Tolerable) | 0         | 0.5**<br>(0.3)    | 4.5**             | (2.97)            | -----           | -----             |
| 10    | OPT OUT COMP | Optional Output -> the secondary output of the synchronized signal, for frequency range see table below  | LV/PECL                     | Vcc-1.680 | Vcc-1.620         | Vcc-1.560         | Vcc-1.085         | Vcc-1.025       | Vcc-0.885         |
| 11    | OPT OUT      | Optional Output -> the secondary output of the synchronized signal, for frequency range see table below. | LV/PECL                     | Vcc-1.680 | Vcc-1.620         | Vcc-1.560         | Vcc-1.085         | Vcc-1.025       | Vcc-0.885         |
| 12    | REF1 HL      | Reference 1 Holdover Input -> the signal HOLDOVER comes from Clock Unit 1                                | DC                          | 0         | 0.25 **<br>(0.15) | 0.5**<br>(0.3)    | 4.5**<br>(2.97)   | 5.0**<br>(3.3)  | 5.25**<br>(3.465) |
| 13    | REF2 HL      | Reference 2 Holdover Input -> the signal HOLDOVER comes from Clock Unit 2                                | DC                          | 0         | 0.25 **<br>(0.15) | 0.5**<br>(0.3)    | 4.5**<br>(2.97)   | 5.0**<br>(3.3)  | 5.25**<br>(3.465) |
| 14    | REF2 AL      | Reference 2 Alarm Input -> the signal ALARM OUT comes from Clock Unit 2                                  | DC                          | 0         | 0.25 **<br>(0.15) | 0.5**<br>(0.3)    | 4.5**<br>(2.97)   | 5.0**<br>(3.3)  | 5.25**<br>(3.465) |
| 15    | ALARM        | Alarm signal -> the output is high when there is an alarm in the module                                  | DC                          | 0         | 0.25 **<br>(0.15) | 0.5**<br>(0.3)    | 4.5**<br>(2.97)   | 5.0**<br>(3.3)  | 5.25**<br>(3.465) |
| 16    | AUTO/MAN     | Auto/Manual configuration input -> selection input for operating mode                                    | DC                          | 0         | 0.25 **<br>(0.15) | 0.5**<br>(0.3)    | 4.5**<br>(2.97)   | 5.0**<br>(3.3)  | 5.25**<br>(3.465) |
| 17    | OUT          | Synchronized Output -> the output of the synchronized signal.  | LV/PECL                     | Vcc-1.680 | Vcc-1.620         | Vcc-1.560         | Vcc-1.085         | Vcc-1.025       | Vcc-0.885         |
| 18    | OUT COMP     | Synchronized Complementary Output -> the output of the synchronized signal.                              | LV/PECL                     | Vcc-1.680 | Vcc-1.620         | Vcc-1.560         | Vcc-1.085         | Vcc-1.025       | Vcc-0.885         |
| 19    | GND          | Ground   | -----                       | -----     | -----             | -----             | -----             | -----           |                   |
| 20    | RV/NRV       | Revert / Non revert input-> selection input for revert feature<br>Revertive="1" ; Non-Revertive = "0"    | DC                          | 0         | 0.25 **<br>(0.15) | 0.5**<br>(0.3)    | 4.5**<br>(2.97)   | 5.0**<br>(3.3)  | 5.25**<br>(3.465) |
| 21    | REF1 AL      | Reference 1 Alarm Input -> the signal ALARM OUT comes from Clock Unit 1                                  | DC                          | 0         | 0.25 **<br>(0.15) | 0.5**<br>(0.3)    | 4.5**<br>(2.97)   | 5.0**<br>(3.3)  | 5.25**<br>(3.465) |
| 22    | REF2 FR      | Reference 2 Free-run Input -> the signal FREERUN comes from Clock Unit 2                                 | DC                          | 0         | 0.25 **<br>(0.15) | 0.5**<br>(0.3)    | 4.5**<br>(2.97)   | 5.0**<br>(3.3)  | 5.25**<br>(3.465) |
| 23    | REF1 FR      | Reference 1 Free-run Input -> the signal FREERUN comes from Clock Unit 1                                 | DC                          | 0         | 0.25 **<br>(0.15) | 0.5**<br>(0.3)    | 4.5**<br>(2.97)   | 5.0**<br>(3.3)  | 5.25**<br>(3.465) |
| 24    | GND          | Ground   | -----                       | -----     | -----             | -----             | -----             | -----           |                   |
| 25    | TLB REF      | Time Loop-back Reference Input -> the input from time loop-back reference                                | DC                          | 0         | 0                 | 0.25 **<br>(0.15) | 0.5**<br>(0.3)    | 4.5**<br>(2.97) | 5.0**<br>(3.3)    |
| 26    | TLB REF COMP | Time Loop-back Reference Complementary Input -> the input from time loop-back                            | DC                          | 0         | 0                 | 0.25 **<br>(0.15) | 0.5**<br>(0.3)    | 4.5**<br>(2.97) | 5.0**<br>(3.3)    |
| 27    | TLB OK       | Time Loop-back OK -> The reference is valid for use.   | DC                          | 0         | 0.25 **<br>(0.15) | 0.5**<br>(0.3)    | 4.5**<br>(2.97)   | 5.0**<br>(3.3)  | 5.25**<br>(3.465) |
| 28    | GND          | Ground   | -----                       | -----     | -----             | -----             | -----             | -----           |                   |

- ORDERING INFORMATION**

- Input Frequencies available

| Frequency  | Suffix | Frequency  | Suffix |
|------------|--------|------------|--------|
| 8KHz       | F8     | 20.4800MHz | A4     |
| 1.024MHz   | E0     | 22.2171MHz | A5     |
| 1.544MHz   | T1     | 26.0000MHz | G2     |
| 2.048MHz   | E1     | 27.0000MHz | A6     |
| 4.096MHz   | E2     | 29.4912MHz | A7     |
| 6.1760MHz  | T2     | 32.768MHz  | E4     |
| 6.480MHz   | D1     | 34.560MHz  | A8     |
| 8.192MHz   | E3     | 37.0560MHz | A9     |
| 10.000MHz  | A1     | 38.880MHz  | O2     |
| 12.800MHz  | S1     | 44.4343MHz | B1     |
| 13.000MHz  | G1     | 44.7360MHz | T3     |
| 15.000MHz  | A2     | 51.8400MHz | D1     |
| 16.384MHz  | E4     | 61.4400MHz | U1     |
| 19.440MHz  | O1     | 62.5000MHz | G1     |
| 20.000MHz  | M1     | 65.5360MHz | B2     |
| 20.1416MHz | A3     | 77.7600MHz | O3     |

- Output Frequencies available

| Frequency  | Suffix | Frequency   | Suffix | Frequency   | Suffix |
|------------|--------|-------------|--------|-------------|--------|
| 1.024MHz   | E0     | 44.4343MHz  | B1     | 178.9440MHz | C4     |
| 1.544MHz   | T1     | 44.7360MHz  | T3     | 184.3200MHz | C5     |
| 2.048MHz   | E1     | 51.8400MHz  | D1     | 311.0400MHz | O5     |
| 4.096MHz   | E2     | 61.4400MHz  | U1     | 622.0800MHz | O6     |
| 6.1760MHz  | T2     | 62.5000MHz  | G1     | 625.000MHz  | C7     |
| 6.480MHz   | D1     | 65.5360MHz  | B2     | 644.5312MHz | C8     |
| 8.192MHz   | E3     | 77.7600MHz  | O3     | 666.5143MHz | C9     |
| 10.000MHz  | A1     | 78.125MHz   | B3     | 669.1281MHz | F1     |
| 12.800MHz  | S1     | 78.6432MHz  | B4     | 669.3266MHz | F2     |
| 13.000MHz  | G1     | 82.9440MHz  | B5     | 690.5692MHz | F3     |
| 15.000MHz  | A2     | 92.6000MHz  | U3     | 710.9486MHz | F4     |
| 16.384MHz  | E4     | 100.000MHz  | B5     | 719.7344MHz | F5     |
| 19.440MHz  | O1     | 112.000MHz  | B6     | 777.6000MHz | F6     |
| 20.000MHz  | M1     | 114.000MHz  | B7     |             |        |
| 20.1416MHz | A3     | 125.000MHz  | G2     |             |        |
| 20.4800MHz | A4     | 133.000MHz  | G3     |             |        |
| 22.2171MHz | A5     | 139.264MHz  | E5     |             |        |
| 26.0000MHz | G2     | 155.520MHz  | O4     |             |        |
| 27.0000MHz | A6     | 156.250MHz  | G4     |             |        |
| 29.4912MHz | A7     | 161.1328MHz | B8     |             |        |
| 32.768MHz  | E4     | 166.6286MHz | B9     |             |        |
| 34.560MHz  | A8     | 167.3316MHz | C1     |             |        |
| 37.0560MHz | A9     | 168.0407MHz | C2     |             |        |
| 38.880MHz  | O2     | 175.0000MHz | C3     |             |        |

➤ **P/N System**

**SY05-HLPL – IP < In Freq>-OU1<Output 1 Freq.>- OU2<Output 1 Freq.>S-T-C <Cover>**

➤ See above Chart ←  
If not listed Place **NL** and state  
the Freq.)

➤ See above Chart ←  
(If Output Freq. Not applied place **NA** and state the Freq.)

➤ See above Chart ←  
(If Output Freq. Not applied place **NA** and state the Freq.)

➤ Supply Voltage; ←  
**2**- 5V  
**4** – 3.3V

➤ Operating Temperature Range; ←  
**C** - 0°C to 70°C  
**I** -40°C to +85°C

➤ Cover Option; ←  
**M** – Metal Cover  
**N** - Non Covered unit

➤ *For other Options please contact the factory*

### MECHANICAL DIMENSIONS

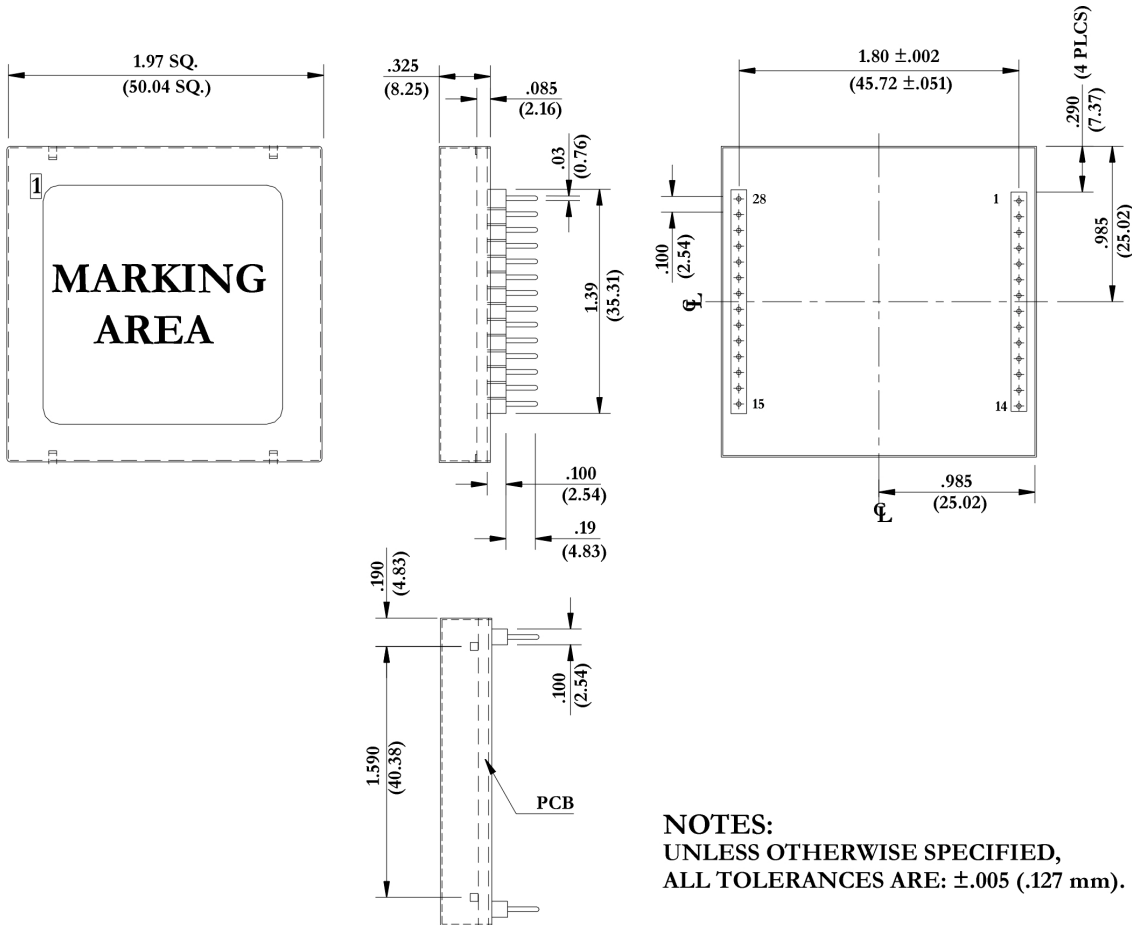

Figure 4 – The mechanical dimensions.

Figure 4 shows the mechanical dimension of the SY05-HLPL module. The module can be supplied in two different types of packaging:

- ✓ Metal box
- ✓ Module without packaging

The dimensions shown on the picture are valid for first and second type of packaging, keeping the pin-out dimensions the same for both. The label on the module shows part number, factory name, week and year of production.

➤ See above Chart

If not listed Place **NL** and state the Freq.)

➤ See Input Freq. Chart  
If Freq. not listed Place **NL**  
and state the Freq.)