

SY01-S3

Date: May 20 , 2002



• INTRODUCTION

The SY01-S3 is an accurate time and frequency source that has been designed as a module level subsystem. The module is designed to work within ATM, SONET, SDH, and wireless systems where synchronization is vital. The SY01-S3 is an OCXO based excellent synchronization solution for timing designed for Stratum 3 applications.

• FEATURES

A Hardware/Software synchronization solution for timing, jitter and wander concerns in a single module.

Complies with ITU-T Recommendations G.813 and ETSI-ETS 300 462-4 and Bellcore GR-1244-CORE for Stratum 3 applications.

Supports four modes of operation: Locked to Reference 1, Locked to Reference 2, Holdover and Free-run.

Accepts reference inputs from two independent sources from **8 kHz to 77.76 MHz**.

Provides two outputs **up to 77.76 MHz**.

Loop filtering utilizing application specific software in the digital signal processor (DSP).

Continuously monitors and evaluate input reference signals.

Creates a history buffer for Holdover mode operation.

Alarm and status signal.

Host interface and JTAG port.

Small dimensions of 1.80X1.80X 0.65 inch (open pkg)

• APPLICATION

The SY01-S3 performs clock regeneration as a Synchronous Equipment Clock (SEC), or STRATUM 3 in ATM, SDH, PDH, and SONET networks. It is designed for manufacturers of network equipment, especially Access Switches, Core Switches, Cross Connects, Digital Multiplexers-Exchangers, and SDH/SONET equipment. The unit is also suitable for PCS, WLL, and Wireless Base Stations. Wherever a Timing unit with high performance specifications is required, the SY01-S3 can be integrated into the network system and provide all necessary frequencies and interfaces. The input stage can receive two different input reference signals at various rates from 4 kHz to 77.76 MHz. An optional application can be achieved by integrating the SY01-S3 with a low cost GPS receiver and locking it to the GPS 1 pps output signal.

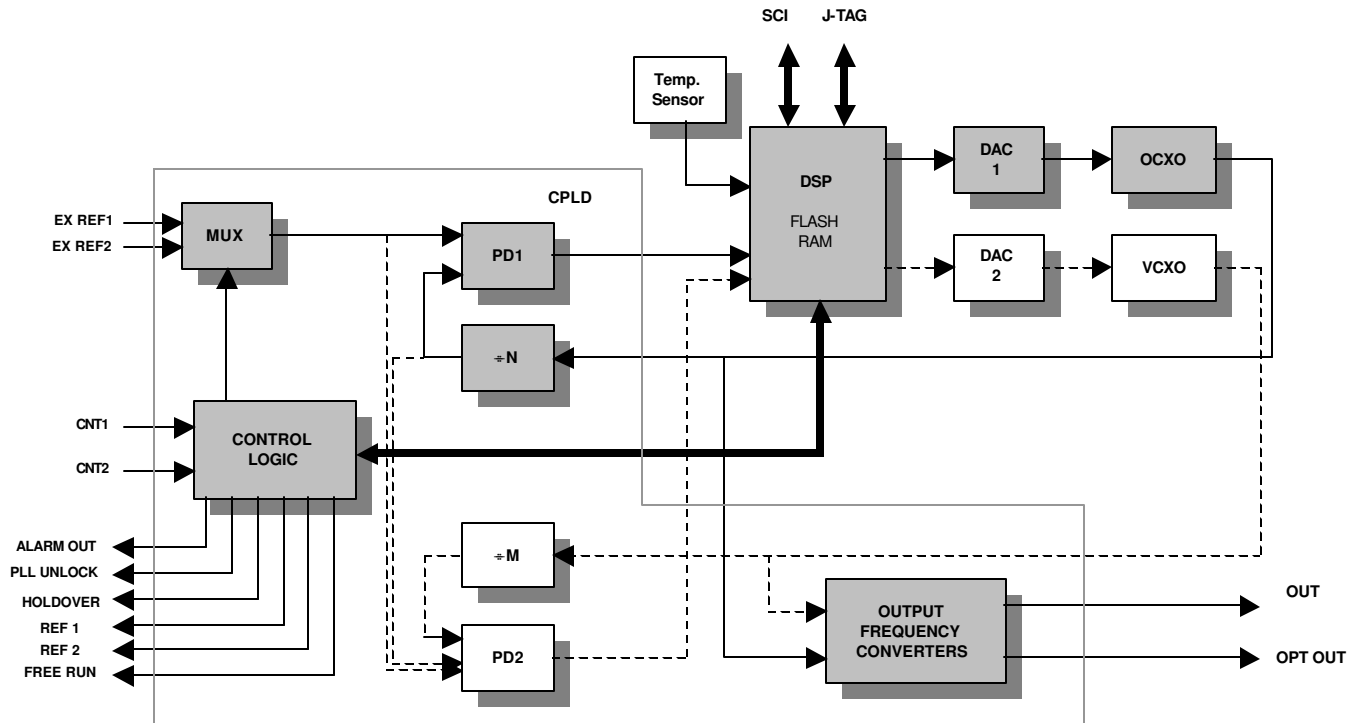

Figure 1. - The functional block diagram of SY01-S3

• DESCRIPTION

The SY01-S3 synchronization module is a Digital PLL (DPLL), which utilizes application specific software in the digital signal processor (DSP). The DSP is complemented by fast hardware logic (CPLD) where all multiplexers, counters, dividers, phase detectors, output frequency converters and other control logic circuits are completely implemented. The functional block diagram with maximum configuration is shown in figure 1. Depending on the application, the user can specify an appropriate configuration to fit their system requirements. The basic configuration utilizes one DPLL with an OCXO as on-board oscillator, shown in figure 1 as the shaded boxes. The OCXO is driven by a digital-to-analog converter (DAC1) and provides the accurate and stable signal under all conditions. The output frequency converters scale the output frequency from the oscillator. For other configurations, please contact Raltron.

✓ The module operates in the following four timing modes:

Free-run

In this mode the unit is unlocked to either of the inputs. The accuracy of the output frequencies in this mode is ± 4.6 ppm. Free-run mode is typically used when a master clock source is required, not valid history of data for the Holdover mode, or immediately following system power-up before network synchronization is achieved. In the Free-run Mode, the SY01-S3 provides timing and synchronization signals that are based on the accuracy of on-board oscillators only, and are not synchronized to the reference signals.

Holdover

In this mode the module has lost its reference inputs and is utilizing stored timing data, called history, to control the output frequency. Holdover Mode is typically used while network synchronization is temporarily disrupted. In Holdover Mode, the SY01-S3 provides timing, based on data from the history buffer, while unlocked to an external reference signal. The history data is determined while the device is locked to an external reference signal. The stability of the output signal in holdover mode depends primarily on the stability of on-board oscillator and environment effects where the clock is mounted. The SY01-S3 uses an OCXO as an on-board oscillator but other types of oscillators are available.

Locked to Ref.1

In this mode the output of the module is phase locked to input reference 1.

Locked to Ref.2

In this mode the output of the module is phase locked to input reference 2.

The REF1 or REF2 Modes are typically used when a slave clock source is synchronized to the network. In these modes, the SY01-S3 provides timing signals, which are synchronized, to one of two references inputs (REF1 or REF2). The input reference signals may have a variety of nominal frequencies, which is typically specified by the end user. When the modes are selected the unit goes through a reference evaluation, and then a frequency acquisition, and finally to phase locking.

- **Input References**

The SY01-S3 module accepts two input references EX REF1 and EX REF2. End users can specify the frequencies within a range of 8 kHz to 77.76 MHz. The input reference signals are HCMOS/TTL levels with timing characteristic in according to Bellcore GR-1244-core 3.2.1.R3-1 or equivalent standards. Please note that the end user must specify the two input frequencies at the time of order.

- **Output Signals**

The SY01-S3 module provides two output signals OUT and OPT OUT. The outputs are generated by the internal oscillator and scaled by the output frequency converters. The performance of the module significantly depends on the internal oscillator and special care was taken to define its specification. A Oven Controlled Crystal Oscillator (OCXO) is used as the internal oscillator. The frequency of the oscillator is specified according to the network application where the SY01-S3 will be used. The frequency converters divide signal from the oscillator to the specified frequencies.

- **The SY01 Operation mode**

By changing the control inputs the user can change the state of the SY01 according to the state diagram. The SY01 offers two ways to manage state machine:

J1 jumper	State diagram control
Open	Manual
Closed	Automatic

The behavior of the Manual and Automatic controls are shown on the figures 2 and 3 with an explanation for each transition. In the Automatic control the SY01 can be automatically switched to the reference (if available) regardless of status of the control inputs. In Manual control the unit waits for control inputs to be changed. In both modes the unit will go to the REFERENCE EVALUATION if the previously lost reference is required.

- **Control**

Two controls are available for the user to control the operation of the SY01. The two external inputs CNT1 and CNT2 provide this feature. Below, the truth table shows behavior of the SY01 module according to the control inputs states.

CNT2	CNT1	MODE OF OPERATION
0	0	Free-run
0	1	Locked to REF1
1	0	Locked to REF2
1	1	Holdover

• **SPECIFICATIONS**

General Specifications	Mechanical	2" (D) x 2" (W) x 0.75" (H) 1.85" (D) x 1.85" (W) x 0.7" (H) 1.8" (D) x 1.8" (W) x 0.65" (H)	Hermetically Sealed Metal box Metal Box Module on PCB
	Power Supply Warm Up Current Supply Steady State Current Supply Operating Temperature Storage Temperature Humidity Internal Oscillators	5VDC 900mA max 400mA max. -20°C to 70°C -40° to 85°C 5% to 95% non-condensing OCXO	Regulated Other ranges available on request
Input Signals	Number of Inputs	2	
	Input reference frequency Signal Level	8kHz to 77.76MHz HCMOS/TTL Compatible	User selectable
	Time Reference characteristics		Bellcore: GR-1244-core 3.2.1.R3-1
Output Signal	Number of Outputs	2	
	Output 1 Output 2	8kHz to 77.76MHz 8kHz to 77.76MHz	User define User define
	Signal Level	HCMOS	Depend of the frequency output
Signal Quality Performance	Jitter Tolerance		Bellcore: GR-1244-core 4.2 ITU-T: G.813
	Phase Transient Tolerance		Bellcore: GR-1244-core 4.4
	Wander Generation		Bellcore: GR-1244-core 5.3 ITU-T: G.812
	Wander Tolerance		Bellcore: GR-1244-core 4.3 ITU-T: G.812
	Jitter Generation and Transfer		Bellcore: GR-1244-core 5.5 ITU-T: G.812
	Wander Transfer		Bellcore: GR-1244-core 5.4 ITU-T: G.812
Frequency Output Performance	Free run accuracy	±4.6ppm	GR-1244-core 5.1 ITU-T: G.812
	Holdover frequency stability	±3.7x10 ⁻⁷ for 24hours	
	Initial Offset	±50x10 ⁻⁹	Bellcore: GR-1244-core 5.2 ITU-T: G.812
	Temperature	±0.28x10 ⁻⁶ ±1.0x10 ⁻⁶	Over operating temperature range
	Drift	±40x10 ⁻⁹	Bellcore: GR-1244-core 5.2 ITU-T: G.812
	DPLL bandwidth	0.1Hz	Or adjustable
	Lock Time	<30sec	GR-1244-core 3.7
	Lock accuracy	±1x10 ⁻¹¹	

• PIN ASSIGNMENT

On the picture below it is shown the pin-out for the SY01-S3. The design is done in such a way that it can support basically any other pin-out without changes in the hardware. For other pin-out requirements please contact the Raltron.

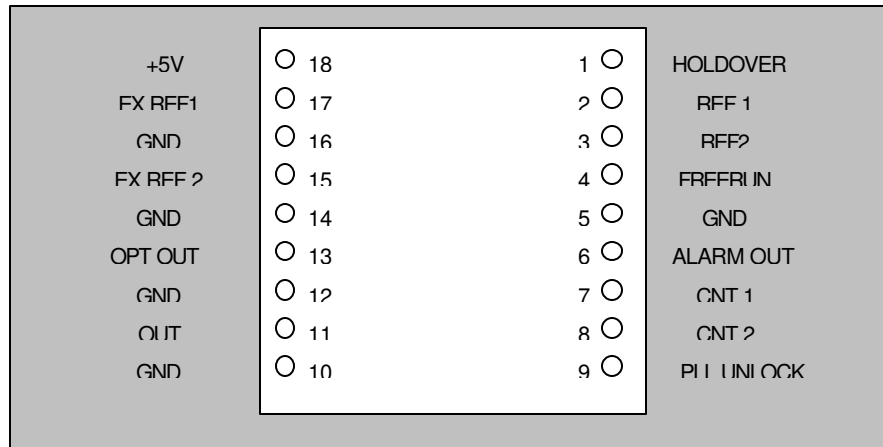
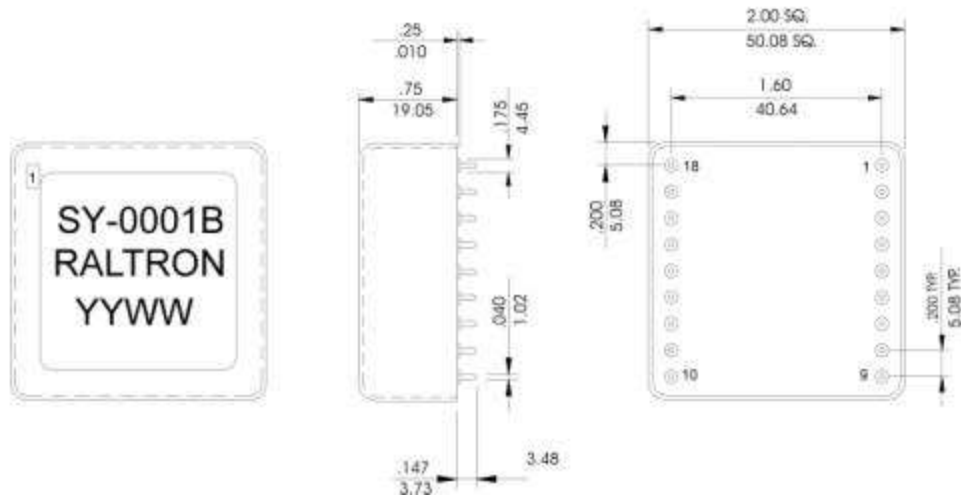

Figure 4 – Bottom view

Pin #	Name	Description
1	HOLDOVER	Holdover Signal -> the output is high when the unit is in holdover mode
2	REF 1	Reference 1 Signal -> the output is high when the unit is using the reference 1
3	REF 2	Reference 2 Signal -> the output is high when the unit is using the reference 2
4	FREERUN	Free-run Signal -> the output is high when the unit is in the free run mode
6	ALARM OUT	Alarm signal -> the output is high when there is an alarm in the module, alarm condition is during free-run mode, holdover mode,
7	CNT 1	Control Input 1 -> the external input for selecting mode of the unit – see table.
8	CNT 2	Control Input 2 -> the external input for selecting mode of the unit – see table.
9	PLL UNLOCK	PLL Unlocked Signal -> the output is high when the unit is not locked to any of the references
5,10,12,14,16	GND	Ground
18	+5V	Positive Voltage Supply
11	OUT	Synchronized Output -> the output of the synchronized signal, for frequency range see table below.
13	OPT OUT	Optional Output -> the secondary output of the synchronized signal, for frequency range see table below.
17	EX REF 1	External Reference 1 Input -> the input signal from reference 1
15	EX REF 2	External Reference 2 Input -> the input signal from reference 2

For other pin-out configurations contact the factory!

- MECHANICAL DIMENSIONS



Hermetically Sealed option

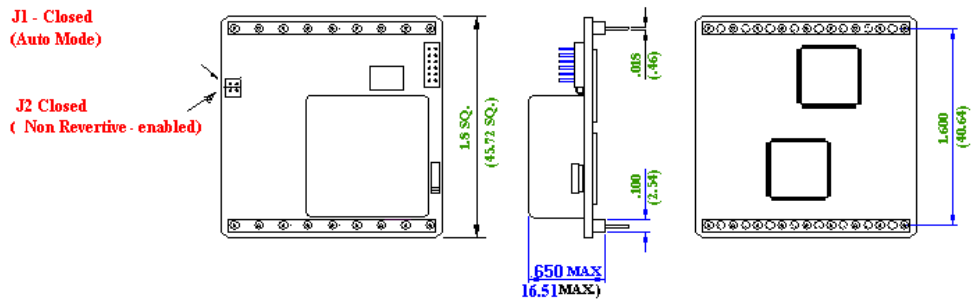

PCB option

- Order Information

Please contact Factory for assigned P/N