

SERIES CX21, CX22, AND CX23

● FEATURES

- COST EFFECTIVE MPU CLOCK
- TOLERANCE AND STABILITY TO ± 5 PPM
- CUSTOM SPECIFICATIONS

● SPECIFICATIONS

FREQUENCY RANGE	1.00 MHz TO 100.00 MHz
FREQUENCY STABILITY OVER TEMPERATURE RANGE (REF. TO25°C)	± 5 PPM TO ± 50 PPM MAX AT VCC = +5.0 VDC (SEE TABLE 1)
OPERATING TEMPERATURE RANGE	0°C TO +50°C (NARROW) 0°C TO +70°C (STANDARD) -40°C TO +85°C (EXTENDED) AT VCC = +5.0VDC AND STANDARD LOAD (SEE TABLE 1)
STORAGE TEMPERATURE RANGE	-40°C TO +85°C
AGING CHARACTERISTICS	± 4 PPM MAX FOR THE FIRST YEAR AND ± 20 PPM MAX FOR 10 YEARS
OUTPUT WAVEFORM OPTIONS	TTL, HCMOS, OR ACNOS
SYMMETRY	NORMAL: 40/60% TIGHT: 45/55% (OPTION)
FREQUENCY STABILITY OVER LOAD VARIATION	± 3 PPM MAX FOR 10% VARIATION AT VCC = +5.0 VDC AT 25°C
SUPPLY VOLTAGE	+5.0 VDC $\pm 5\%$ (3.3 VDC AVAILABLE)
ENABLE/DISABLE FUNCTION	CONTROL PIN 1: HIGH OR OPEN (+2.0 VDC MIN)OUTPUT PIN 8: ENABLED CONTROL PIN 1: LOW OR GROUND (+0.8 VDC MIN)OUTPUT PIN 8: DISABLED (HIGH Z)
FREQUENCY STABILITY OVER SUPPLY VOLTAGE VARIATION	± 5 PPM MAX FOR 5% VARIATION AT VCC = +5.0 VDC AND STANDARD LOAD AT 25°C
SUPPLY CURRENT	50 mA MAX AT VCC = +5.0 VDC AND STANDARD LOAD AT 25°C



● OUTLINE DRAWING

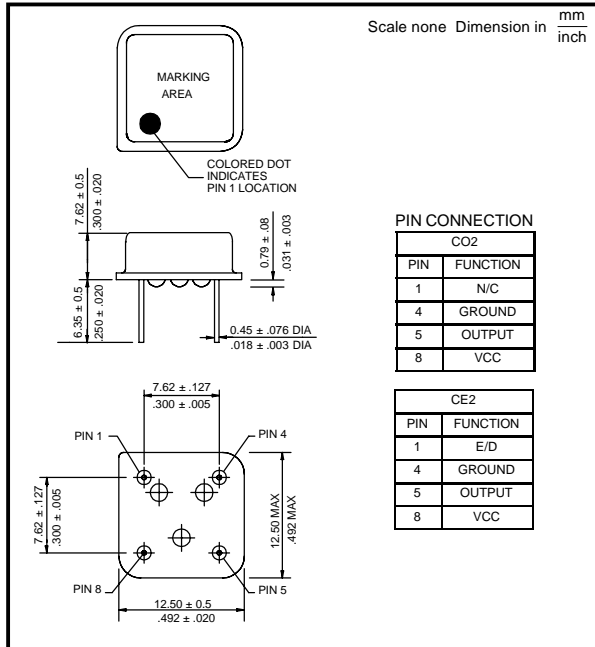

● TEMPERATURE RANGE DESIGNATIONS

TABLE 1		
CODE	TEMPERATURE RANGE	TEMPERATURE STABILITY
A	0°C TO +50°C	± 5 PPM
B	0°C TO +50°C	± 10 PPM
C	0°C TO +50°C	± 15 PPM
D	0°C TO +50°C	± 20 PPM
E	0°C TO +50°C	± 25 PPM
F	0°C TO +70°C	± 10 PPM
G	0°C TO +70°C	± 15 PPM
H	0°C TO +70°C	± 20 PPM
I	0°C TO +70°C	± 25 PPM
J	0°C TO +70°C	± 35 PPM
K	0°C TO +70°C	± 50 PPM
L	-40°C TO +85°C	± 20 PPM
M	-40°C TO +85°C	± 25 PPM
O	-40°C TO +85°C	± 30 PPM
P	-40°C TO +85°C	± 35 PPM
Q	-40°C TO +85°C	± 50 PPM

● PHASE NOISE CHARACTERISTICS

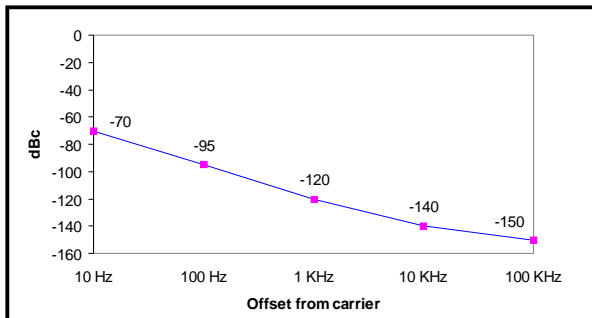

● PART NUMBERING SYSTEM

SERIES	OUTPUT	CODE	FREQUENCY	SYMMETRY
CO2	1 TTL	A THROUGH M	IN MHZ	T (45/55%)
	2 HCMOS			
CE2	3 ACNOS			

EXAMPLE:

CO22L-20.000-T

HCMOS OUTPUT ± 20 PPM OVER -40° C TO +85° C

TIGHT SYMMETRY