

Rancho SysTech Inc

PO Box 4796
Rancho Cucamonga, CA 91729
Phone and Fax 909-987-3966

www.rancho.com

RTSASR-12X

12-Port Serial Attached SCSI (SAS)
Edge Expander

Operating Manual



June 2009
Version 1.0e

TABLE OF CONTENTS

OVERVIEW..... 3
GENERAL FEATURES 3
SPECIFICATIONS 4
LED Color Pattern 4
CONFIGURATIONS 5
CABLE CONFIGUATIONS 5
SAS ROUTING..... 6
APPLICATIONS..... 6
Simple topology 7
Multiple initiators and targets 8
Cascading 8
Path redundancy 9
EXPANDER COMMUNICATION 9



To protect the global environment, Rancho Systech, Inc. reminds you that the European Union (“EU”) Directive on Waste Electrical and Electronic Equipment, Directive 2002/96/EU, which took effect August 13, 2005, states that products of “electrical and electronic equipment” cannot be discarded as municipal waste. Manufacturers of covered electronic equipment will be obligated to take back such products at the end of their useful life, Rancho Systech, Inc. will comply with the product take back requirements at the end of life of Rancho Systech, Inc. branded products that are sold into the EU. You can return these products to local collection points.

OVERVIEW and GENERAL FEATURES

The RTSASR-12X is a 12-port, 3Gb/s Serial Attached SCSI Edge Expander in a 1U rackmount chassis. It is fully compliant with ANSI Serial Attached SCSI specification with improved performance, cabling, and power requirements. The RTSASR-12X supports Serial Attached SCSI Protocol, SAS management protocol, Serial ATA protocol, and Serial ATA tunneling protocol. The RTSASR-12X expander supports both 1.5Gb/s and 3Gb/s data transfer per port.

Rancho's RTSASR-12X expander complies with SAS standard and enhanced reliability compared to parallel SCSI. Rancho's SAS expander provides functionality for connecting targets and initiators with up to 12 phys integrated for SAS initiators, SAS targets, SAS expanders, or Serial ATA (SATA) target devices. The RTSASR-12X supports both wide and narrow port configurations.

- ? 1.72 x 17 x 16 inches, fits 1U 19" rack mount
- ? Weight 12.5 lbs
- ? 12 full independent SAS and SATA ports
- ? Supports SSF, STP, SMP, and SATA standards
- ? Supports multiple data rates and auto negotiation (SAS only)
 - o SAS – 3.0Gb/s
 - o SATA – 1.5Gb/s
- ? Supports direct, subtractive decode, and table routing
- ? SATA/SAS HDD spin up sequencing
- ? Provide low latency connection router
- ? Provide configurable drive spin up sequencing on per phy basis
- ? Front and back Act/Fault LED light indicators
- ? Allows concurrent connections for SAS and SATA targets
- ? Allows Addressing of multiple SATA targets
- ? Allows multiple initiators to address a single target
- ? Decode SMP packets that are destined for the expander
- ? Performs CRC checking and generation on the request frames and response frames
- ? UART interface for debug functions

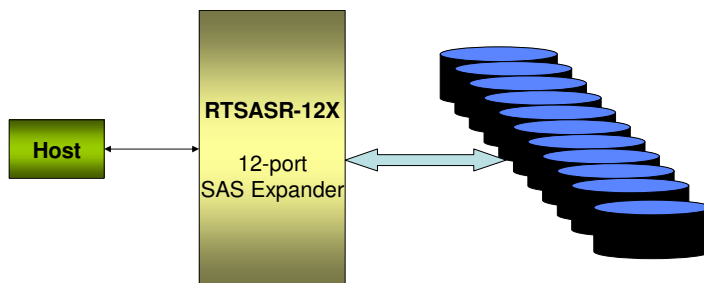

Figure 1: SAS topology offers high scalability

SPECIFICATIONS

Operating Voltages	100-240 VAC @ 50/60Hz
Power consumption	10 Watts
Data Connector	3 x SFF-8470 (4X connector) Serial Port – DB9 HSSDC2 – 1X Infiniband
Throughput	3.0Gb/s – SAS 1.5Gb/s – SATA
Operating temperature	0-50° C
Altitude	3000 meters
Relative humidity	5-95% (non condensing)



Figure 2: Front view



Figure 3: Back view

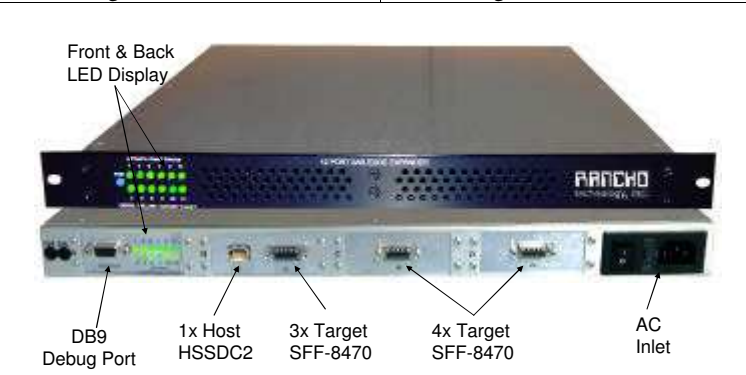

Figure 4: Data connector descriptions.
Green = Activity, Yellow = Fault

LED Color Pattern

Yellow = Fault

1. Medium blink rate when waiting for spin up
2. Fast blink rate when between OOB and first FIS
3. Solid yellow when device is not READY
4. Off when device is connected and ready

Green = Activity

CONFIGURATIONS

Host and Target configurations

- ? Host Connector: 1X Infiniband connector
- ? Target: 4X and 3X connector
- ? Debug: Serial Port (DB9)

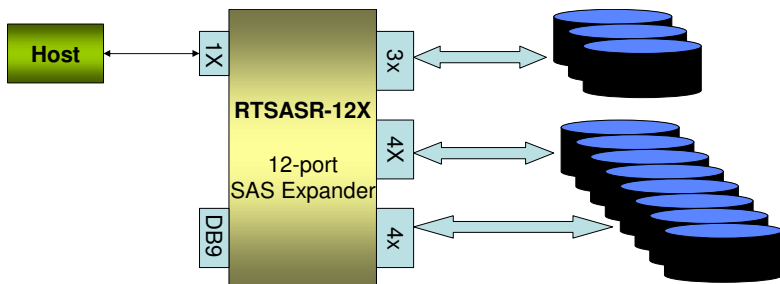
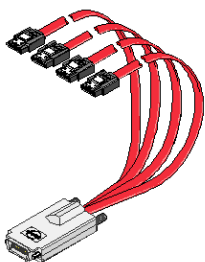

Figure 5: Basic SAS topology

The RTSASR-12X provides up to 11 SAS/SATA target devices. Port [3:1] is available on the first 4X connector from the left near the LED indicator on the back side of the enclosure. Port [10:4] is available on the other two 4X connectors. Port0 is reserved for HBA interface. Refer to Figure 4 on the previous page for their physical locations.

Cable requirements

- ? Host: 1x External Infiniband to 1x SATA
- ? Target: 4x External (SFF-8470) to 1x SAS/SATA (SFF-8482)



SFF-8470 Plug				SATA SIGNALS
Signal	Pin	Signal	Pin	
RX0+	S1	TX0+	S16	SATA 0
RX0-	S2	TX0-	S15	
RX1+	S3	TX1+	S14	SATA 1
RX1-	S4	TX1-	S13	
RX2+	S5	TX2+	S12	SATA 2
RX2-	S6	TX2-	S11	
RX3+	S7	TX3+	S10	SATA 3
RX3-	S8	TX3-	S9	
G1-G9:	Signal Ground			
Housing	Chassis Ground			

Figure 6: 4x external (SFF-8470) to 1x SAS/SATA

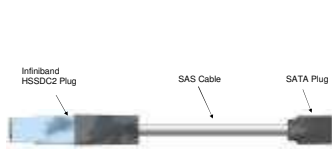

HSSDC2		SATA	
Signal	Pin	Pin	Signal
G	1	7	G
R+	2	6	T+
R-	3	5	T-
G	4	4	G
T-	5	3	R-
T+	6	2	R+
G	7	1	G

Figure 7: 1x Infiniband HSSDC2 to 1x SATA crossover cable

CABLE CONFIGURATIONS and SAS ROUTING

The RTSASR-12X supports direct routing, table routing, and subtractive routing. The individual routing method is configurable for each individual port.

DIRECT ROUTING

Direct routing is done on the SAS initiators, SAS/SATA targets that direct attached to one of the RTSASR-12X port. Rancho SAS expander does not use subtractive or table routing in this configuration.

SUBTRACTIVE ROUTING

Subtractive routing occurs when the RTSASR-12X routes unresolved addresses to a specific port. Subtractive routing is enabling through the register bus interface.

TABLE ROUTING

The RTSASR-12X supports up to 144 routing table entries. Table routing is used for cascading multiple SAS expander. Refer to Figure 9 for typical application in this topology.

SAS PORT CONFIGURATION

Port[04:01] = Subtractive
Port[12:05] = Table

By default, all ports support direct attach devices.

APPLICATIONS

SAS Edge Expanders are ideal for servers and hard drive enclosure to provide interface connection for multiple devices.

Typical applications

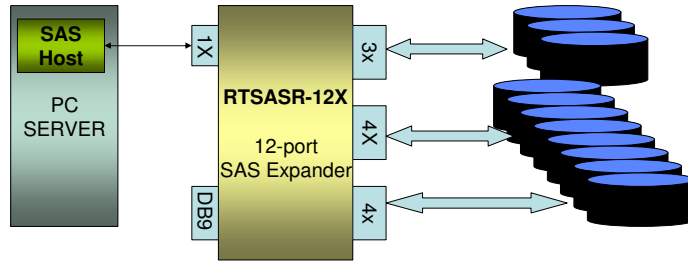

Figure 8: Server with multiple SAS/SATA target devices.

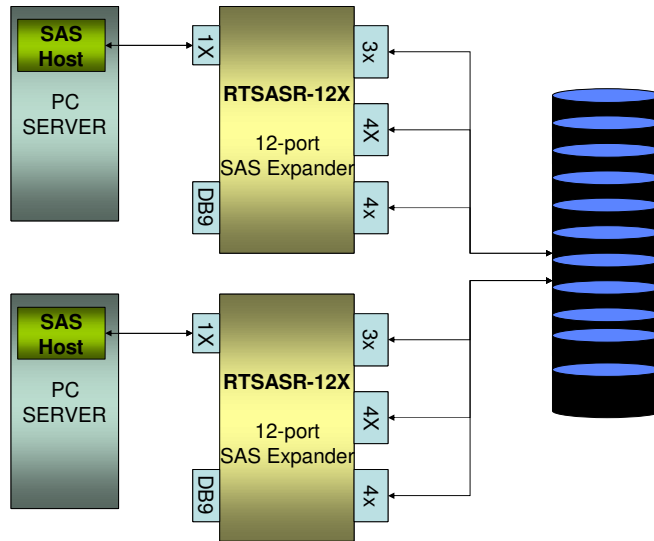

Figure 9: Multiple initiator and multiple target

APPLICATIONS...Continued

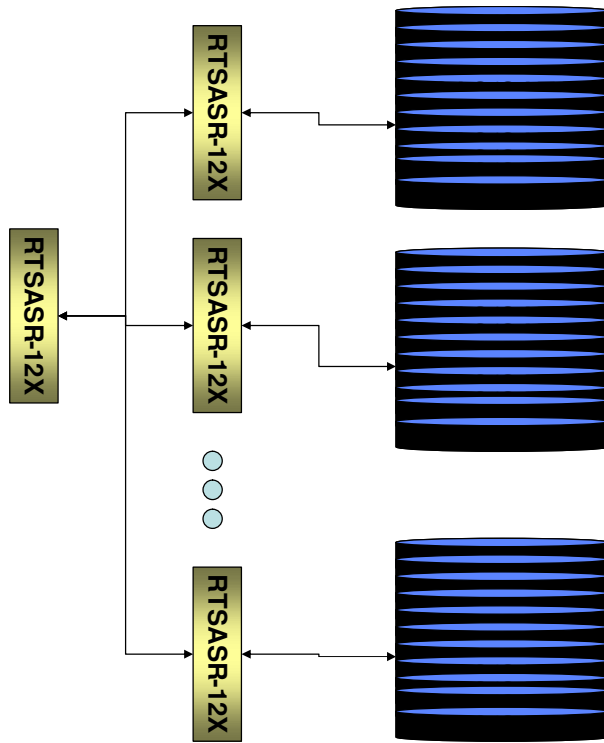

Figure 10: Multiple Expanders Cascading

This SAS topology supports up to 144 devices by cascading 12 Rancho's RTSASR-12X expanders. The primary SAS expander on the left hand side of Figure 10 acts like a fan out expander for other SAS expander. The primary expander uses table routing to route traffic between expanders in this topology.

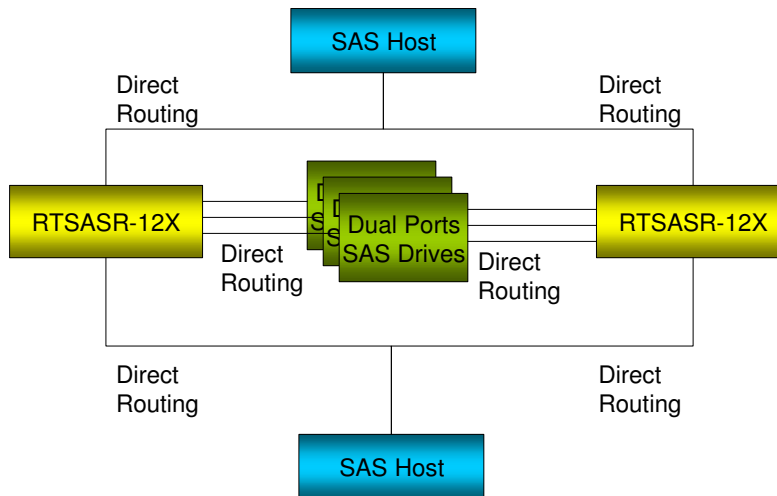

Figure 11: Path redundancy application

EXPANDER COMMUNICATION

Rancho RTSASR-12X supports Serial Protocol (SSP), Serial ATA Tunneled Protocol (STP), Serial Management Protocol (SMP), and Serial ATA Protocol (SATA). SSP provides SCSI mapping command that supports initiators, targets and enabling the expander to communicate with other SSP devices. STP maps SATA commands to support multiple initiators and targets, and enabled the RTSASR-12X to communicate with SATA devices.

Rancho Systech, Inc.
 Telephone and Fax : (909) 987-3966
 Website: <http://www.rancho.com>
 General information: scsi@rancho.com
 Technical support: support@rancho.com
 Sales: sales@rancho.com
 Copyright 2004

Information in this manual is subject to change without notice.
 Rancho Systech, Inc. assumes no responsibility for errors appearing in or information omitted from this manual.