

## Gallium Nitride 28V, 50W, DC-2.5 GHz HEMT

Built using the SIGANTIC<sup>®</sup> process - A proprietary GaN-on-Silicon technology

### Features

- Suitable for linear and saturated applications
- Tunable from DC-2.5 GHz
- 28V Operation
- Industry Standard Package
- High Drain Efficiency (>60%)
- Rugged Design Passes 15:1 VSWR test
- Reliable with MTTF > 10<sup>6</sup> at T<sub>J</sub> = 200°C

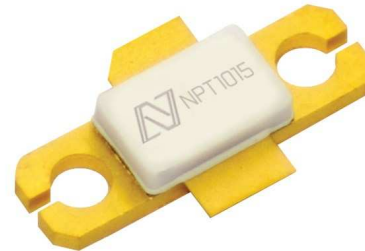

### Applications

- Defense Communications
- Land Mobile Radio
- Avionics
- Wireless Infrastructure
- ISM Applications
- VHF/UHF/L-Band Radar

**DC-2.5 GHz**  
**50W**  
**GaN HEMT**



### Product Description

The NPT1015 GaN HEMT is a wideband transistor optimized for DC-2.5 GHz operation. This device has been designed for CW, pulsed, and linear operation with output power levels to 50W (47 dBm) in an industry standard metal-ceramic package with a bolt down flange. This product has been designed to be reliable, with a low thermal resistance, and rugged, able to withstand extreme mismatch on the input and output with no device damage.

**RF Specifications (CW, 2.5 GHz):** V<sub>DS</sub> = 28V, I<sub>DQ</sub> = 400mA, T<sub>C</sub> = 25°C

Symbol	Parameter	Min	Typ	Max	Units
G <sub>SS</sub>	Small-signal Gain	-	13.5	-	dB
P <sub>SAT</sub>	Saturated Output Power	-	47.5	-	dBm
η <sub>SAT</sub>	Efficiency at Saturated Output Power	-	61	-	%
G <sub>P</sub>	Gain at P <sub>OUT</sub> = 45W	-	12	-	dB
η	Drain Efficiency at P <sub>OUT</sub> = 45W	-	56	-	%
V <sub>DS</sub>	Drain Voltage	-	28	-	V
Ψ	Ruggedness: Output Mismatch, All Phase Angles	VSWR = 15:1, No Device Damage			

# NPT1015



DC Specifications:  $T_C = 25^\circ\text{C}$

Symbol	Parameter	Min	Typ	Max	Units
<b>Off Characteristics</b>					
$I_{DLK}$	Drain-Source Leakage Current ( $V_{GS}=-8\text{V}$ , $V_{DS}=100\text{V}$ )	-	-	16	mA
$I_{GLK}$	Gate-Source Leakage Current ( $V_{GS}=-8\text{V}$ , $V_{DS}=0\text{V}$ )	-	-	8	mA
<b>On Characteristics</b>					
$V_T$	Gate Threshold Voltage ( $V_{DS}=28\text{V}$ , $I_D=16\text{mA}$ )	-2.3	-1.7	-1.1	V
$V_{GSQ}$	Gate Quiescent Voltage ( $V_{DS}=28\text{V}$ , $I_D=400\text{mA}$ )	-2.1	-1.5	-0.9	V
$R_{ON}$	On Resistance ( $V_{DS}=2\text{V}$ , $I_D=120\text{mA}$ )	-	0.3	-	$\Omega$
$I_{D, MAX}$	Maximum Drain Current ( $V_{DS}=7\text{V}$ pulsed, 300 $\mu\text{s}$ pulse width, 0.2% Duty Cycle)	-	9.2	-	A

## Thermal Resistance Specification:

Symbol	Parameter	Typ	Units
$R_{\theta JC}$	Thermal Resistance (Junction-to-Case), $T_J = 180^\circ\text{C}$	2.1	$^\circ\text{C/W}$

Junction Temperature ( $T_J$ ) measured using IR Microscopy, Case Temperature ( $T_C$ ) measured using a thermocouple embedded in heatsink.

## Absolute Maximum Ratings: Not simultaneous, $T_C = 25^\circ\text{C}$ unless otherwise noted

Symbol	Parameter	Max	Units
$V_{DS}$	Drain-Source Voltage	100	V
$V_{GS}$	Gate-Source Voltage	-10 to 3	V
$I_G$	Gate Current	32	mA
$P_T$	Total Device Power Dissipation (Derated above $25^\circ\text{C}$ )	83	W
$T_{STG}$	Storage Temperature Range	-65 to 150	$^\circ\text{C}$
$T_J$	Operating Junction Temperature	200	$^\circ\text{C}$
HBM	Human Body Model ESD Rating (per JESD22-A114)	Class 1B	

## Load-Pull Data, Reference Plane at Device Leads

$V_{DS}=28V$ ,  $I_{DQ}=400mA$ ,  $T_C=25^\circ C$  unless otherwise noted

### Optimum Source and Load Impedances:

(CW Drain Efficiency and Output Power Tradeoff Impedance)

Frequency (MHz)	$Z_S (\Omega)$	$Z_L (\Omega)$	$P_{SAT} (W)$	$G_{SS} (dB)$	Drain Efficiency @ $P_{SAT}$ (%)
900	$1.1 - j0.3$	$6.3 + j1.0$	53.7	22.5	65.1
2200	$1.7 - j8.5$	$5.5 - j2.8$	53.2	15.8	64.8
2500	$1.6 - j9.6$	$5.3 - j4.8$	50.9	15.0	60.8

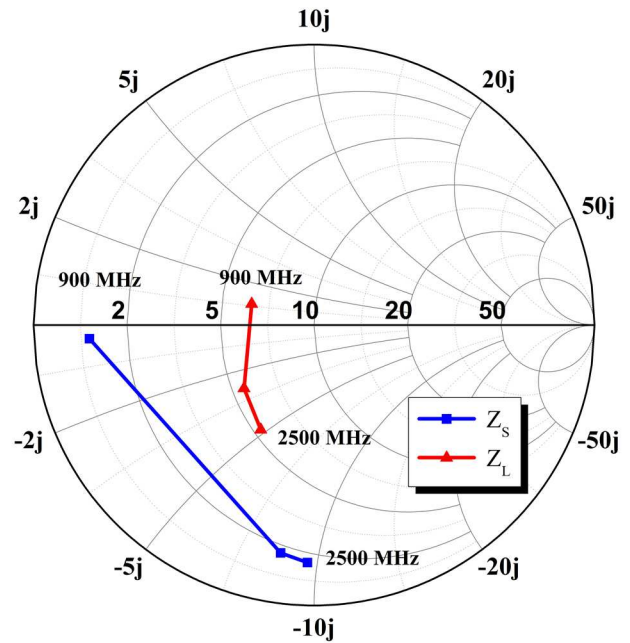
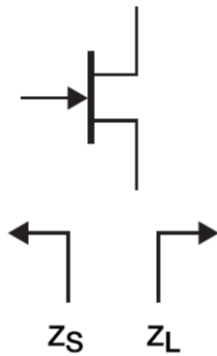

**Figure 1: CW Power/Drain Efficiency Tradeoff Impedances,  $Z_O=10\Omega$**

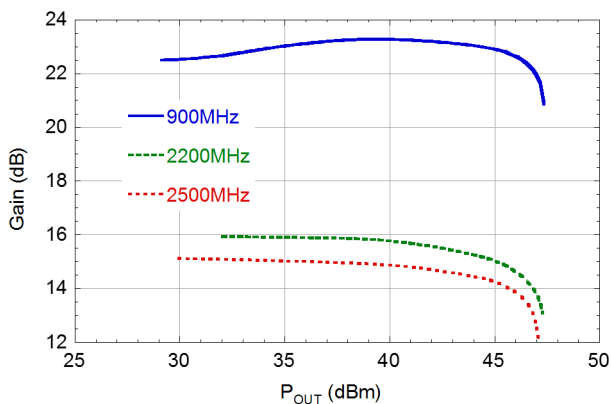

**Figure 2: Gain vs.  $P_{OUT}$**

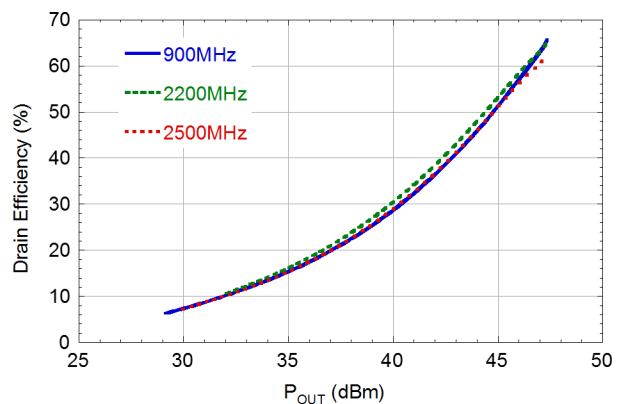

**Figure 3: Drain Efficiency vs.  $P_{OUT}$**

## 2.5 GHz Narrowband Circuit

(CW,  $V_{DS}=28V$ ,  $I_{DQ}=400mA$ ,  $T_C=25^{\circ}C$ , unless otherwise noted)

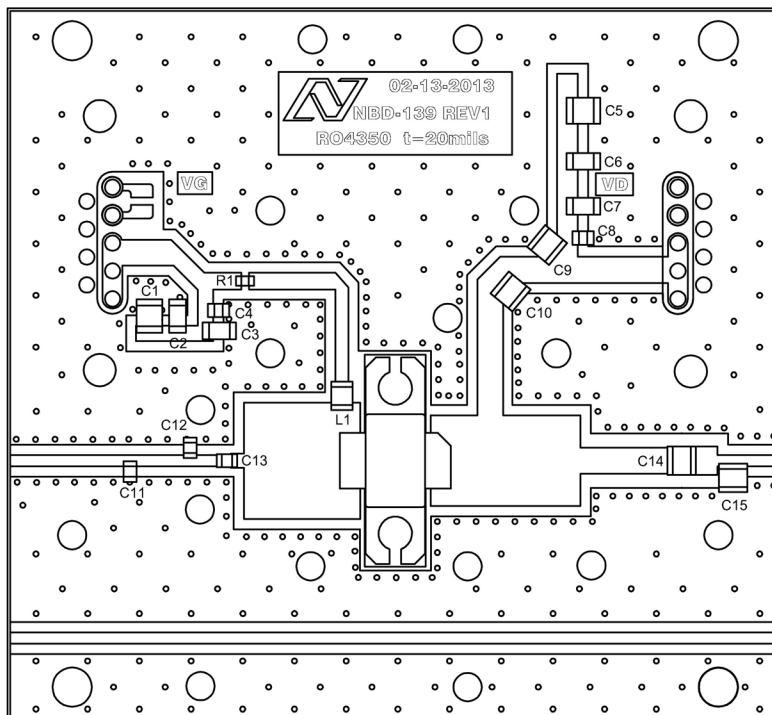
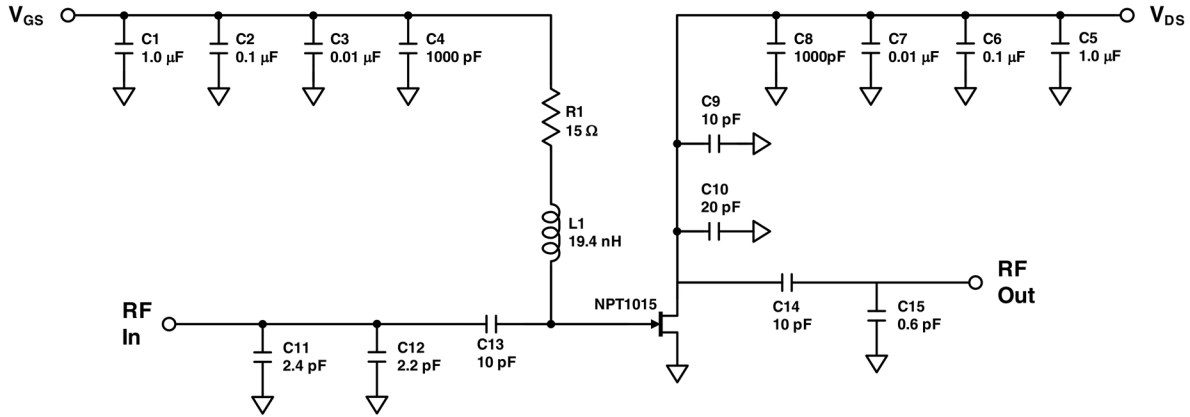

**Figure 4:** Component Placement of 2.5 GHz Narrowband Circuit for NPT1015

Reference	Value	Manufacturer	Part Number
C1, C5	1uF	AVX	1210C105KAT2A
C2, C6	0.1uF	Kemet	C1206C104K1RACTU
C3, C7	0.01uF	AVX	1206C103KAT2A
C4, C8	1000pF	Kemet	C0805C102K1RACTU
C9, C14	10pF	ATC	ATC800B100B
C10	20pF	ATC	ATC800B200B
C11	2.4pF	ATC	ATC600F2R4B
C12	2.2pF	ATC	ATC600F2R2B
C13	10pF	ATC	ATC600F100B
C15	0.6pF	ATC	ATC600F0R6B
L1	19.4nH	CoilCraft	0806SQ-19NJL
R1	15Ω	Panasonic	ERJ-2RKF15R0X
PCB	RO4350, $\epsilon_r=3.5$ , 0.020"	Rogers	Nitronex NBD-139r1

## Typical Performance in 2.5 GHz Narrowband Circuit

(CW,  $V_{DS}=28V$ ,  $I_{DQ}=400mA$ ,  $f=2.5GHz$ ,  $T_C=25^\circ C$ , unless otherwise noted)



**Figure 5.** Electrical Schematic of 2.5 GHz Narrowband Circuit for NPT1015  
(For RF Tuning details see Component Placement Diagram Figure 4)

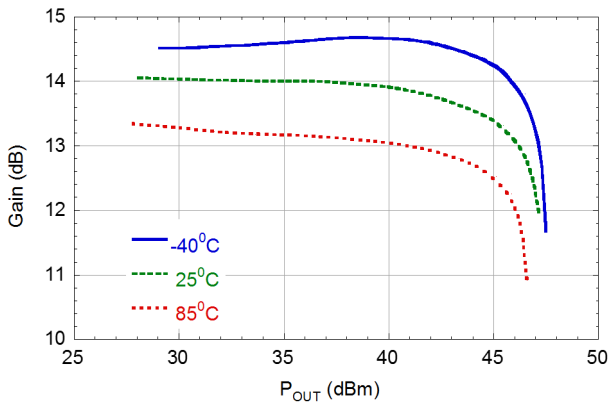

**Figure 6:** Gain vs.  $P_{OUT}$

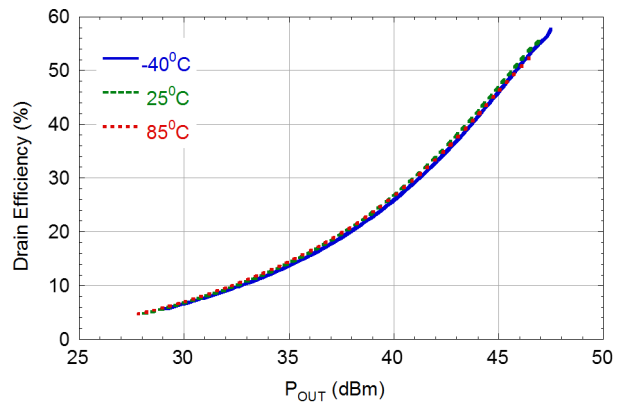

**Figure 7:** Drain Efficiency vs.  $P_{OUT}$

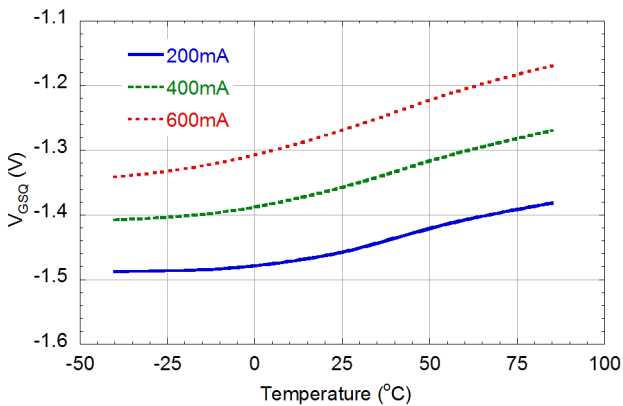

**Figure 8:** Quiescent  $V_{GS}$  vs. Temperature

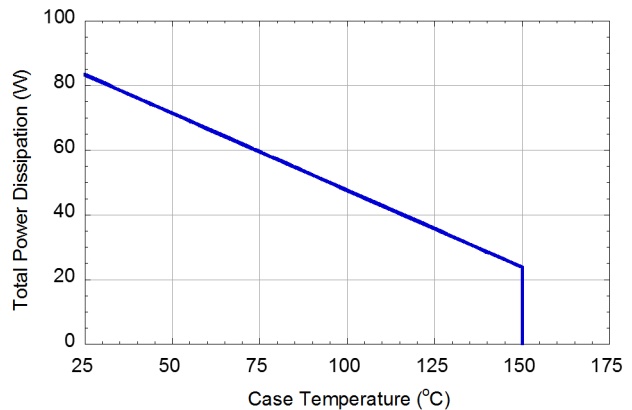

**Figure 9:** Power De-rating Curve  
( $T_J = 200^\circ C$ ,  $T_C > 25^\circ C$ )

## Typical Performance in 2.5 GHz Narrowband Circuit

(CW,  $V_{DS}=28V$ ,  $I_{DQ}=400mA$ ,  $f=2.5GHz$ ,  $T_C=25^\circ C$ , unless otherwise noted)

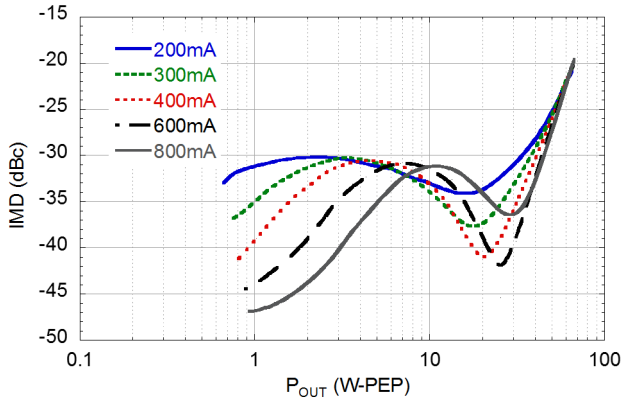

**Figure 10:** 2-Tone IMD3 vs.  $P_{OUT}$  vs.  $I_{DQ}$   
(1MHz Tone Spacing)

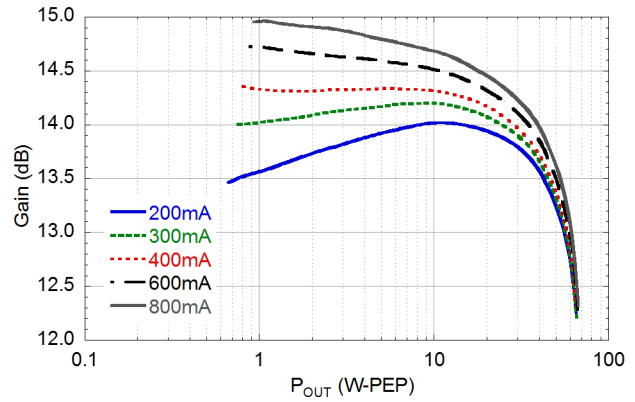

**Figure 11:** 2-Tone Gain vs.  $P_{OUT}$  vs.  $I_{DQ}$   
(1MHz Tone Spacing)

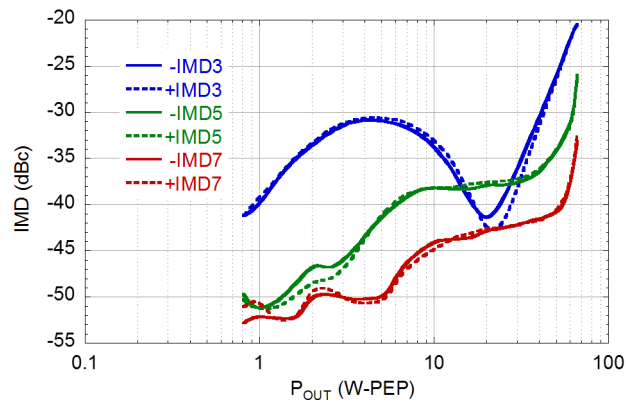

**Figure 12:** 2-Tone IMD vs.  $P_{OUT}$   
(1MHz Tone Spacing)

## 600-1000 MHz Broadband Circuit

(CW,  $V_{DS}=28V$ ,  $I_{DQ}=400mA$ ,  $T_C=25^\circ C$ , unless otherwise noted)

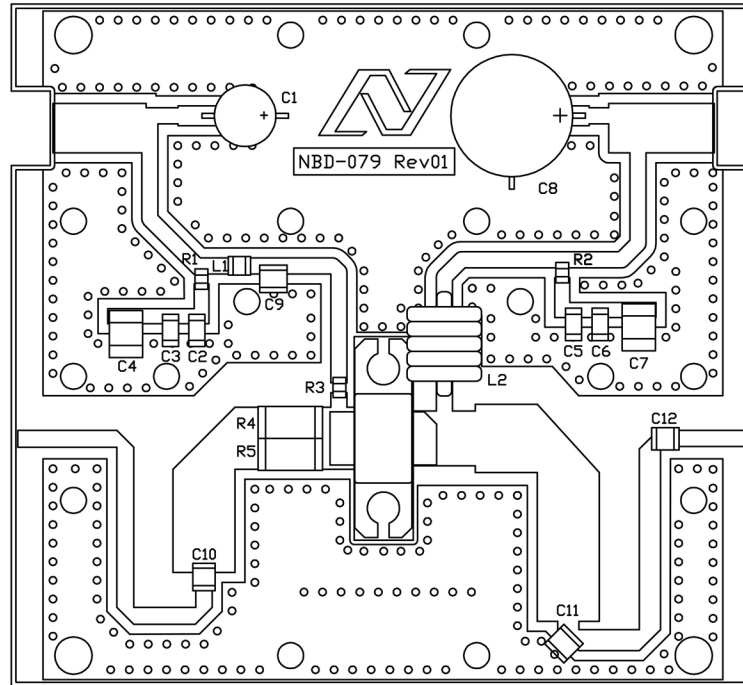
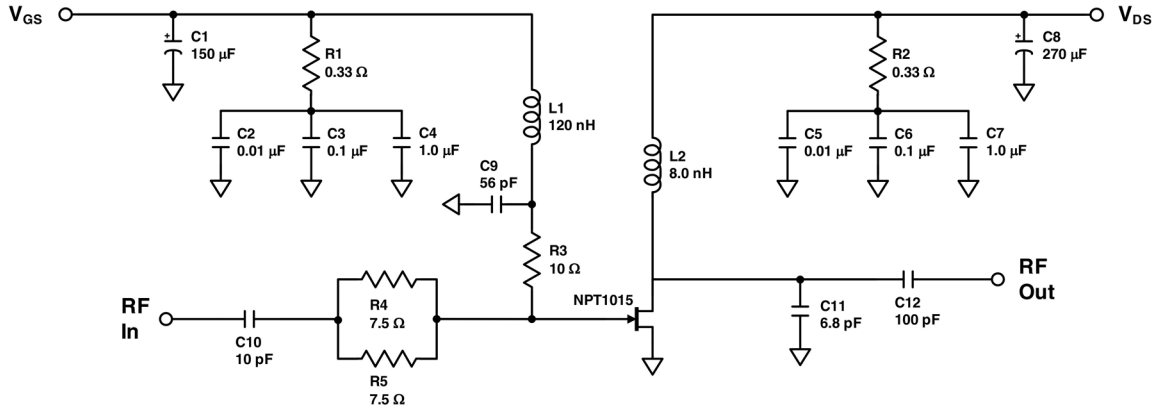

**Figure 13:** Component Placement of 600-1000 MHz Broadband Circuit for NPT1015

Reference	Value	Manufacturer	Part Number
C1	150uF	Nichicon	UPW1C151MED
C2, C5	0.01uF	AVX	1206C103KAT2A
C3, C6	0.1uF	Kemet	C1206C104K1RACTU
C4, C7	1uF	AVX	1210C105KAT2A
C8	270uF	United Chemi-Con	ELXY 630ELL271MK25S
C9	56pF	ATC	ATC100B560J
C10, C12	100pF	ATC	ATC100B101J
C11	6.8pF	ATC	ATC100B6R8J
R1, R2	0.33Ω	Panasonic	ERJ-6RQFR33V
R3	10Ω	Panasonic	ERJ-6ENF10R0V
R4, R5	7.5Ω	Stackpole	RHC2512FT7R50
L1	120nH	Coilcraft	0805CS-121XJB
L2	~50nH	16 AWG Cu Wire	5 turn, 0.2"ID
PCB	RO4350, $\epsilon_r=3.5$ , 0.020"	Rogers	Nitronex NBD-079r1

## Typical Performance in 600-1000 MHz Broadband Circuit

(CW,  $V_{DS}=28V$ ,  $I_{DQ}=400mA$ ,  $T_C=25^\circ C$ , unless otherwise noted)



**Figure 14.** Electrical Schematic of 600-1000 MHz Broadband Circuit for NPT1015  
(For RF Tuning details see Component Placement Diagram Figure 13)

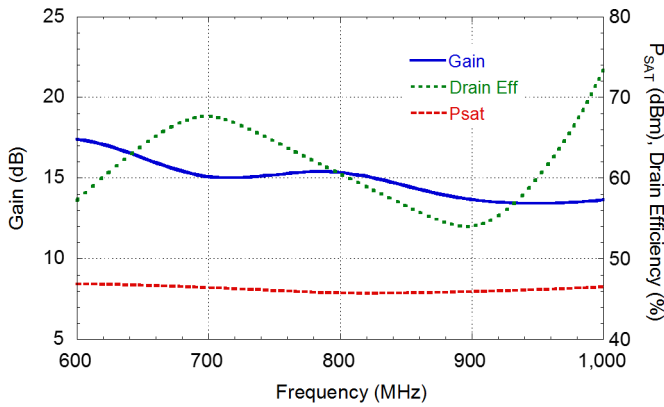

**Figure 15:** Performance vs. Frequency  
( $P_{OUT} = P_{SAT}$ )

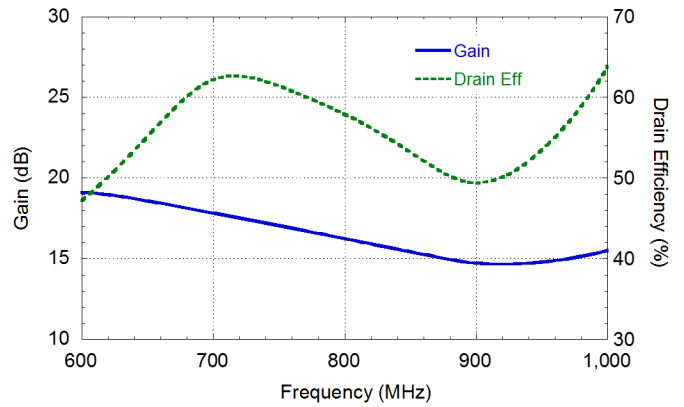

**Figure 16:** Performance vs. Frequency  
( $P_{OUT} = 45dBm$ )

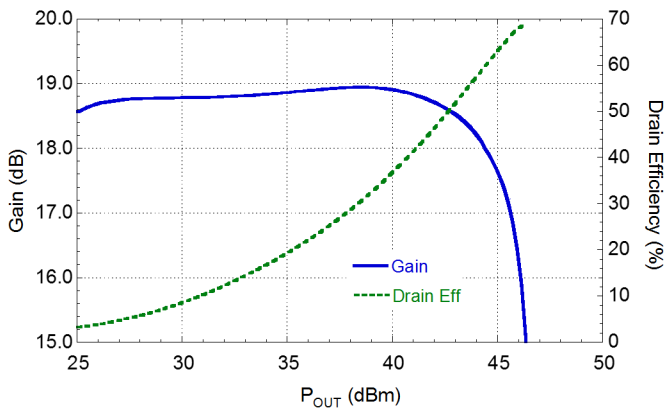

**Figure 17:** Gain/Drain Efficiency vs.  $P_{OUT}$   
( $f = 700MHz$ )

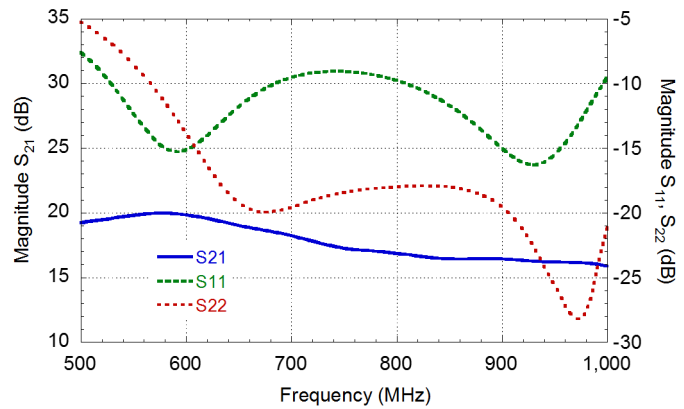

**Figure 18:** Small Signal s-parameters vs. Frequency

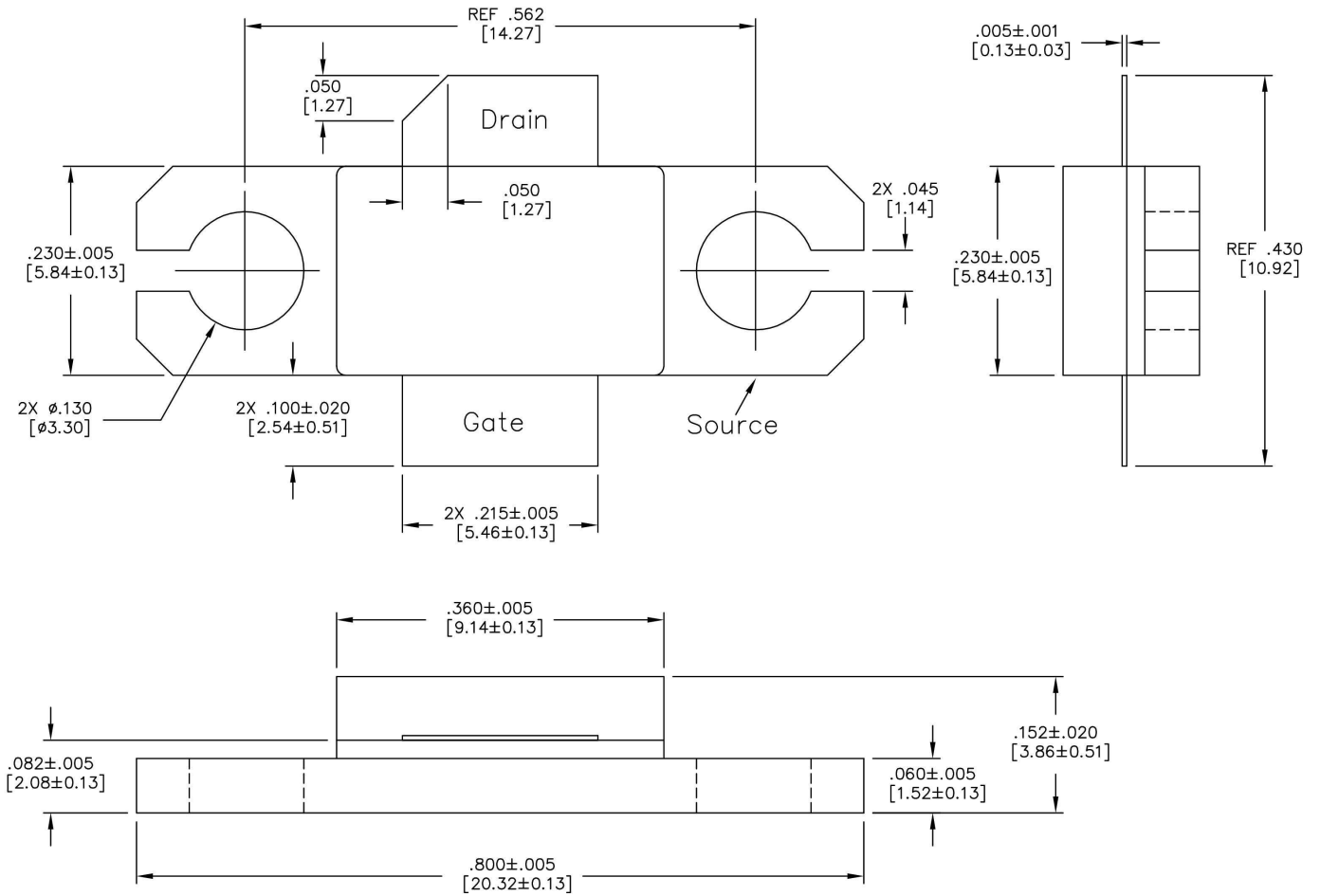

**Figure 19** - AC360B-2 Metal-Ceramic Package Dimensions (all dimensions in inches [millimeters])

Function
Gate — RF Input
Drain — RF Output (Cut lead)
Source — Ground (Flange)

## Nitronex, LLC

2305 Presidential Drive  
Durham, NC 27703 USA  
+1.919.807.9100 (telephone)  
+1.919.807.9200 (fax)  
[info@nitronex.com](mailto:info@nitronex.com)  
[www.nitronex.com](http://www.nitronex.com)

## Additional Information

**This part is lead-free and is compliant with the RoHS directive  
(Restrictions on the Use of Certain Hazardous Substances in Electrical and Electronic Equipment).**

## Important Notice

Nitronex, LLC reserves the right to make corrections, modifications, enhancements, improvements and other changes to its products and services at any time and to discontinue any product or service without notice. Customers should obtain the latest relevant information before placing orders and should verify that such information is current and complete. All products are sold subject to Nitronex terms and conditions of sale supplied at the time of order acknowledgment. The latest information from Nitronex can be found either by calling Nitronex at 1-919-807-9100 or visiting our website at [www.nitronex.com](http://www.nitronex.com).

Nitronex warrants performance of its packaged semiconductor or die to the specifications applicable at the time of sale in accordance with Nitronex standard warranty. Testing and other quality control techniques are used to the extent Nitronex deems necessary to support the warranty. Except where mandated by government requirements, testing of all parameters of each product is not necessarily performed.

Nitronex assumes no liability for applications assistance or customer product design. Customers are responsible for their product and applications using Nitronex semiconductor products or services. To minimize the risks associated with customer products and applications, customers should provide adequate design and operating safeguards.

Nitronex does not warrant or represent that any license, either express or implied, is granted under any Nitronex patent right, copyright, mask work right, or other Nitronex intellectual property right relating to any combination, machine or process in which Nitronex products or services are used.

Reproduction of information in Nitronex data sheets is permitted if and only if said reproduction does not alter any of the information and is accompanied by all associated warranties, conditions, limitations and notices. Any alteration of the contained information invalidates all warranties and Nitronex is not responsible or liable for any such statements.

Nitronex products are not intended or authorized for use in life support systems, including but not limited to surgical implants into the body or any other application intended to support or sustain life. Should Buyer purchase or use Nitronex, LLC products for any such unintended or unauthorized application, Buyer shall indemnify and hold Nitronex, LLC, its officers, employees, subsidiaries, affiliates, distributors, and its successors harmless against all claims, costs, damages, and expenses, and reasonable attorney fees arising out of, directly or indirectly, any claim of personal injury or death associated with such unintended or unauthorized use, notwithstanding if such claim alleges that Nitronex was negligent regarding the design or manufacture of said products.

Nitronex and the Nitronex logo are registered trademarks of Nitronex, LLC.

All other product or service names are the property of their respective owners.

©Nitronex, LLC 2013 All rights reserved.