

Gallium Nitride 28V, 125W RF Power Transistor

Built using the SIGANTIC® NRF1 process - A proprietary GaN-on-Silicon technology

FEATURES

- Optimized for CW, pulsed, WiMAX, W-CDMA, LTE and other applications from 2100 – 2700MHz
- 125W P_{3dB} Peak envelope power
- 90W P_{3dB} CW power
- 10W linear power @ 2.0% EVM for single carrier OFDM, 10.3dB peak/avg, 10MHz channel bandwidth, 16.5dB gain, 26% efficiency
- Characterized for operation up to 32V
- 100% RF tested
- Thermally enhanced industry standard package
- High reliability gold metallization process
- Lead-free and RoHS compliant
- Subject to ECCN 3A982.a.1 export control

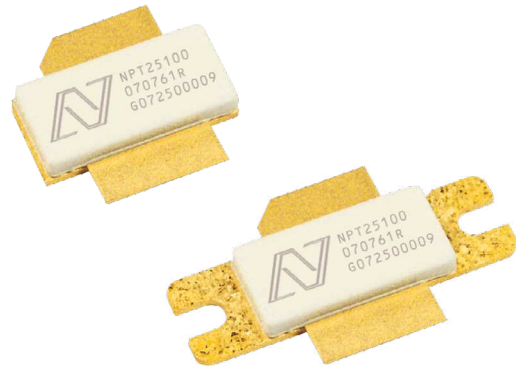

2100 – 2700 MHz
125 Watt, 28 Volt
GaN HEMT



RF Specifications (CW): $V_{DS} = 28V$, $I_{DQ} = 600mA$, Frequency = 2500MHz, $T_C = 25^\circ C$, Measured in Nitronex Test Fixture

Symbol	Parameter	Min	Typ	Max	Units
P_{3dB}	Average Output Power at 3dB Gain Compression	80	90	-	W
G_{SS}	Small Signal Gain	14	16.5	-	dB
η	Drain Efficiency at 3dB Gain Compression	55	62	-	%

Typical 2-Tone Performance: $V_{DS} = 28V$, $I_{DQ} = 600mA$, Frequency = 2500MHz, Tone spacing = 1MHz, $T_C = 25^\circ C$
 Measured in Load Pull System (Refer to Table 1 and Figure 1)

Symbol	Parameter	Typ	Units
$P_{3dB,PEP}$	Peak Envelope Power at 3dB Compression	125	W
$P_{1dB,PEP}$	Peak Envelope Power at 1dB Compression	90	W
P_{IMD3}	Peak Envelope Power at -35dBm IMD3	80	W

Typical OFDM Performance: $V_{DS} = 28V$, $I_{DQ} = 600mA$, Single carrier OFDM waveform 64-QAM 3/4, 8 burst, continuous frame data, 10MHz channel bandwidth. Peak/Avg = 10.3dB @ 0.01% probability on CCDF.
 Frequency = 2500 to 2700MHz. $P_{OUT,AVG} = 10W$, $T_C = 25^\circ C$.

Symbol	Parameter	Typ	Units
G_P	Power Gain	16.5	dB
η	Drain Efficiency	26	%
EVM	Error Vector Magnitude	2.0	%

DC Specifications: $T_C = 25^\circ\text{C}$

Symbol	Parameter	Min	Typ	Max	Units
Off Characteristics					
V_{BDS}	Drain-Source Breakdown Voltage ($V_{GS} = -8\text{V}$, $I_D = 36\text{mA}$)	100	-	-	V
I_{DLK}	Drain-Source Leakage Current ($V_{GS} = -8\text{V}$, $V_{DS} = 60\text{V}$)	-	9	18	mA
On Characteristics					
V_T	Gate Threshold Voltage ($V_{DS} = 28\text{V}$, $I_D = 36\text{mA}$)	-2.3	-1.8	-1.3	V
V_{GSQ}	Gate Quiescent Voltage ($V_{DS} = 28\text{V}$, $I_D = 700\text{mA}$)	-2.0	-1.5	-1.0	V
R_{ON}	On Resistance ($V_{GS} = 2\text{V}$, $I_D = 270\text{mA}$)	-	0.13	0.14	Ω
$I_{D,MAX}$	Drain Current ($V_{DS} = 7\text{V}$ pulsed, 300 μs pulse width, 0.2% duty cycle)	-	21.0	-	A

Thermal Resistance Specification

Symbol	Parameter	Min	Typ	Max	Units
θ_{JC}	Thermal Resistance (Junction-to-Case), $T_J = 145^\circ\text{C}$	-	1.75	-	$^\circ\text{C}/\text{W}$

Absolute Maximum Ratings: Not simultaneous, $T_C = 25^\circ\text{C}$ unless otherwise noted

Symbol	Parameter	Max	Units
V_{DS}	Drain-Source Voltage	100	V
V_{GS}	Gate-Source Voltage	-10 to 3	V
I_G	Gate Current	180	mA
P_T	Total Device Power Dissipation (Derated above 25°C)	100	W
T_{STG}	Storage Temperature Range	-65 to 150	$^\circ\text{C}$
T_J	Operating Junction Temperature	200	$^\circ\text{C}$
HBM	Human Body Model ESD Rating (per JESD22-A114)	2 (>2000V)	
MM	Machine Model ESD Rating (per JESD22-A115)	M2 (>100V)	

Table 1: Optimum Source and Load Impedances for CW Gain, Drain Efficiency, and Output Power Performance, $V_{DS} = 28V$, $I_{DQ} = 600mA$

Frequency (MHz)	$Z_S (\Omega)$	$Z_L (\Omega)$
2140	12.1 - j20.0	2.6 - j2.6
2300	10.0 - j3.0	2.5 - j2.3
2400	9.5 - j3.0	2.5 - j2.5
2500	9.0 - j3.0	2.5 - j2.7
2600	8.5 - j3.0	2.5 - j3.1
2700	8.0 - j3.0	2.5 - j3.3

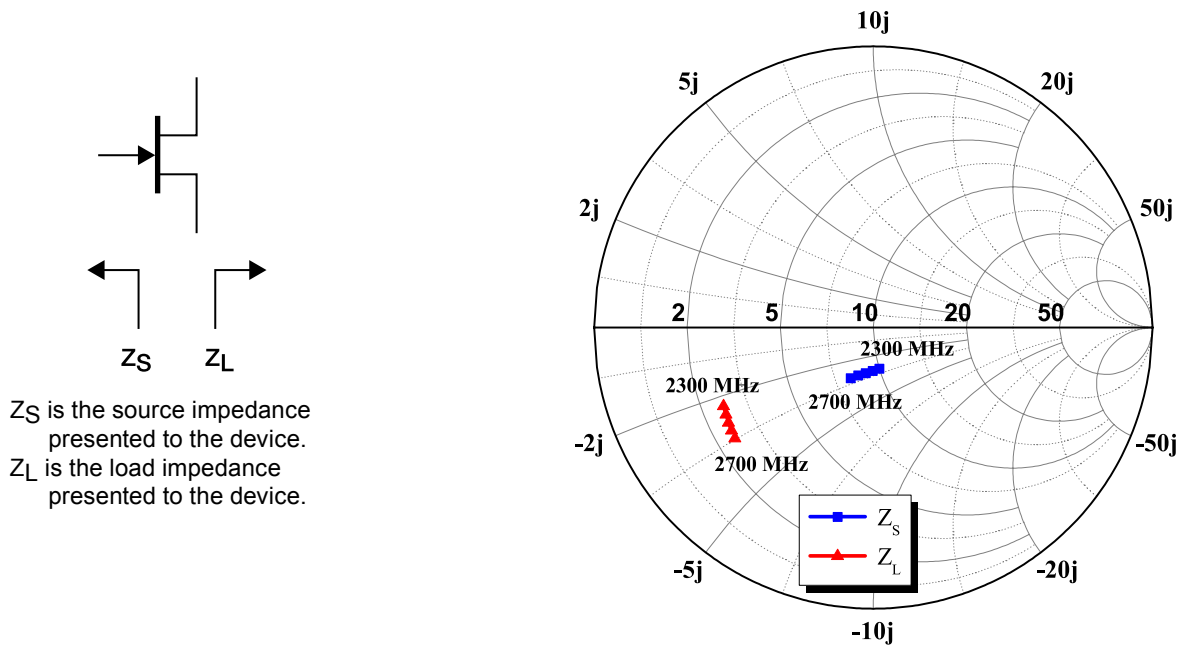

Figure 1 - Optimal Impedances for CW Performance, $V_{DS} = 28V$, $I_{DQ} = 600mA$

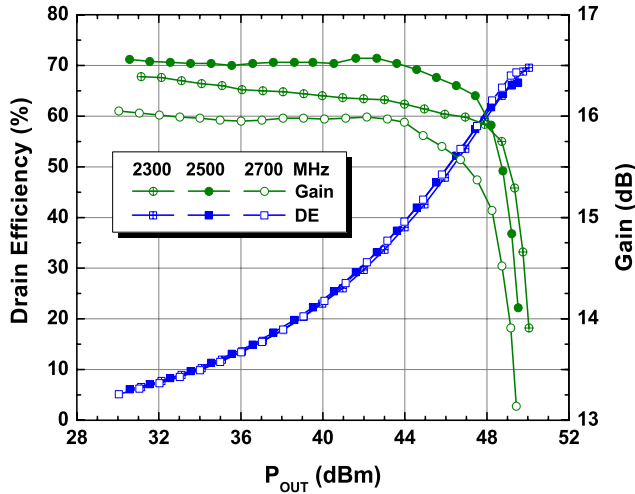

Figure 2 - Typical CW Performance in Load-Pull System, $V_{DS} = 28V$, $I_{DQ} = 600mA$, Frequency = 2300 to 2700MHz

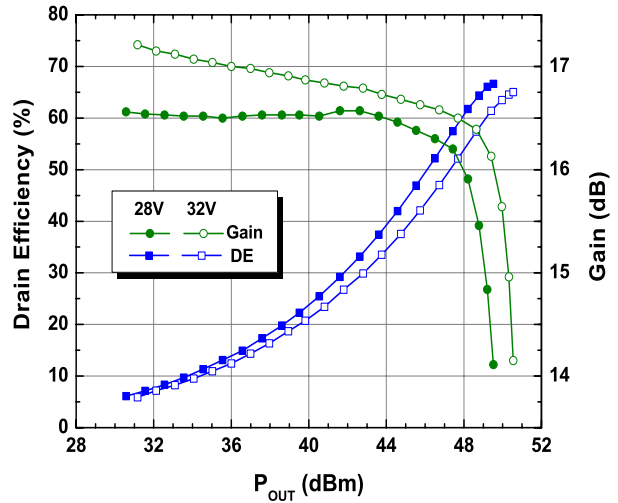

Figure 3 - Typical CW Performance in Load-Pull System, $V_{DS} = 28V$ & $32V$, $I_{DQ} = 600mA$, Frequency = 2500MHz, Impedances Held Constant

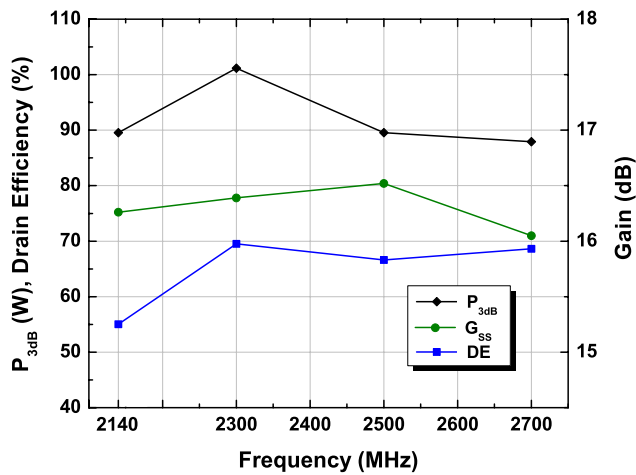

Figure 4 - Typical CW Performance in Load Pull System, $V_{DS} = 28V$, $I_{DQ} = 600mA$

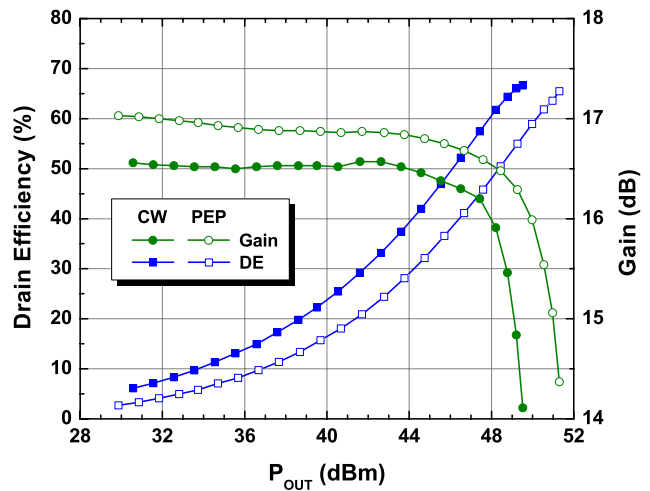

Figure 5 - Typical CW and PEP Performance in Load-Pull System, $V_{DS} = 28V$, $I_{DQ} = 600mA$, Frequency = 2500MHz, Tone Spacing = 1MHz

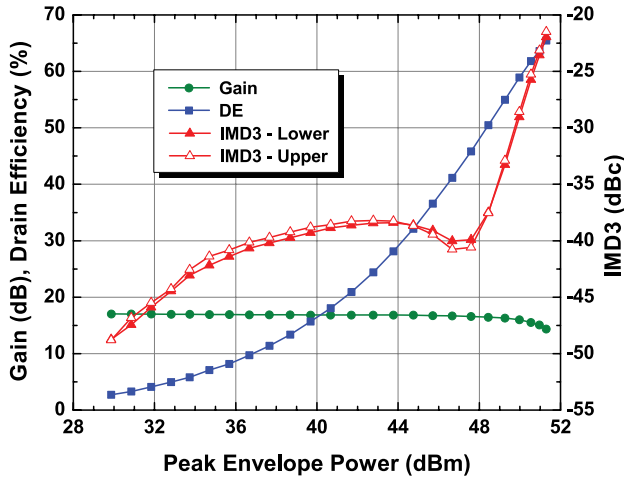

Figure 6 - Typical IMD3 Performance in Load-Pull System, $V_{DS} = 28V$, $I_{DQ} = 600mA$, Frequency = 2500MHz, Tone Spacing = 1MHz

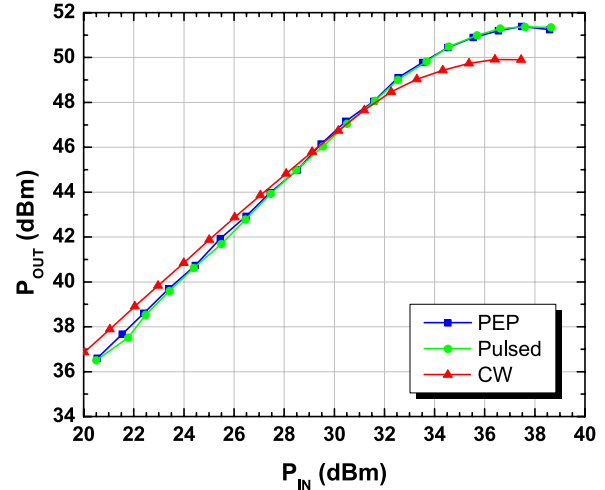

Figure 7 - Typical CW, PEP, and Pulsed Performance in Load-Pull System, Pulse Width = 10 μs , Duty Cycle = 1%, $V_{DS} = 28V$, $I_{DQ} = 600mA$, Frequency = 2500MHz, Tone Spacing = 1MHz

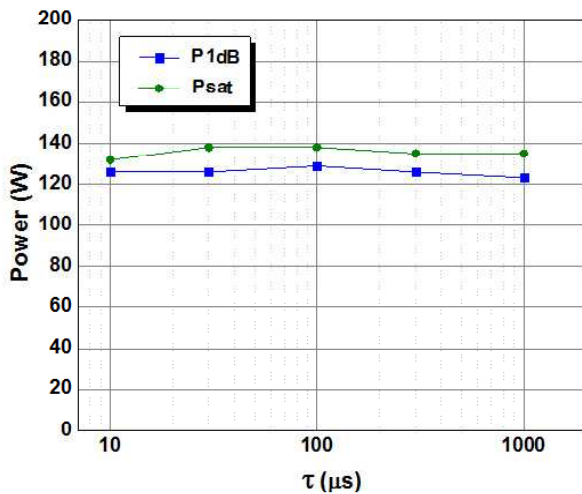

Figure 8 - Typical Pulsed CW Performance in Load-Pull System, 1% Duty Cycle, $V_{DS} = 28V$, $I_{DQ} = 600mA$, Frequency = 2500MHz

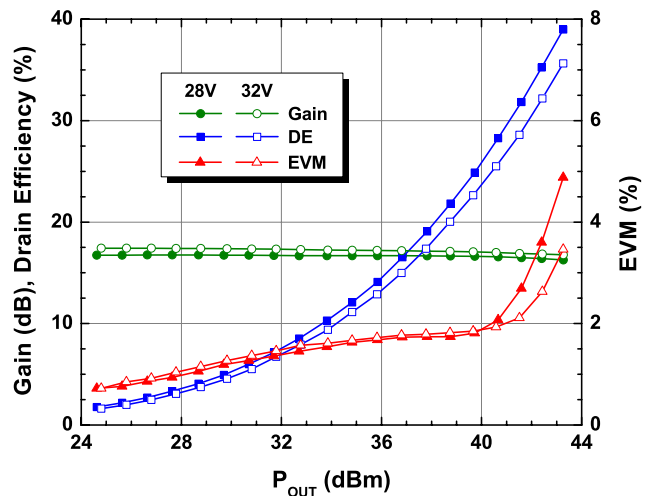

Figure 9 - Typical OFDM Performance in Load-Pull System, $V_{DS} = 28V$ & 32V, $I_{DQ} = 600mA$, Frequency = 2500MHz

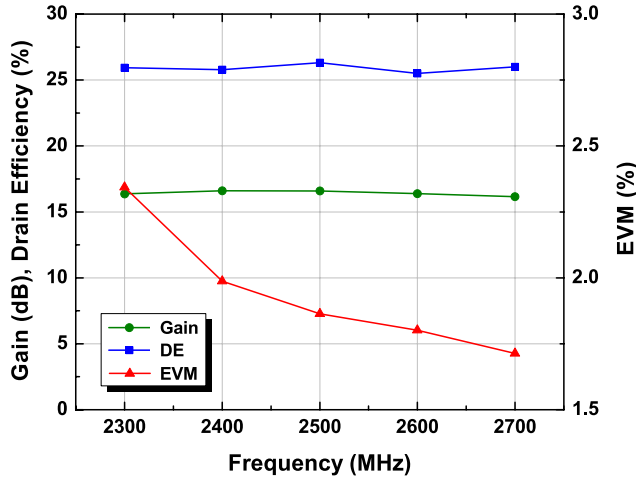

Figure 10 - Typical OFDM Performance in Load-Pull System, $P_{OUT,AVG} = 10W$, $V_{DS} = 28V$, $I_{DQ} = 600mA$

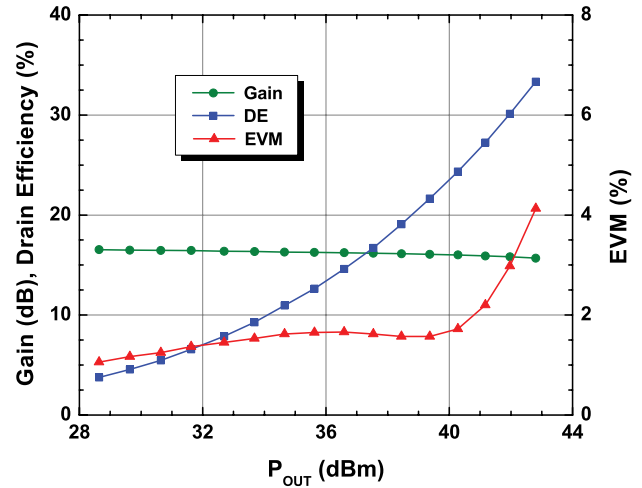

Figure 11 - Typical LTE (Long Term Evolution, 20MHz channel), Nitronex Test Fixture, $V_{DS} = 28V$, $I_{DQ} = 600mA$, Frequency = 2600MHz

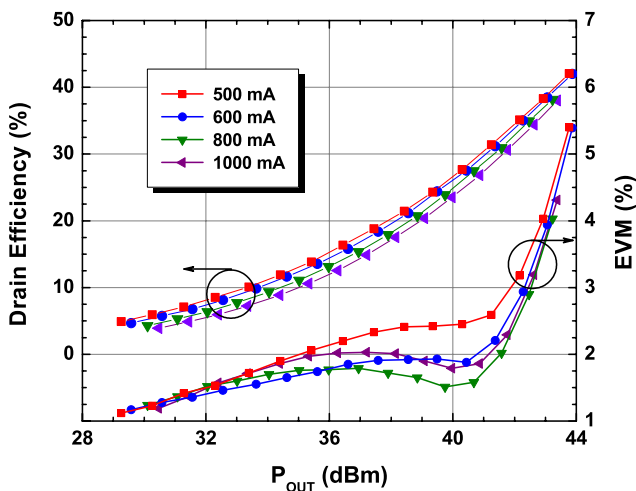

Figure 12 - OFDM Performance in Nitronex Test Fixture as a Function of I_{DQ} , $V_{DS} = 28V$, $I_{DQ} = 500$ to $1000mA$, Frequency = 2500MHz

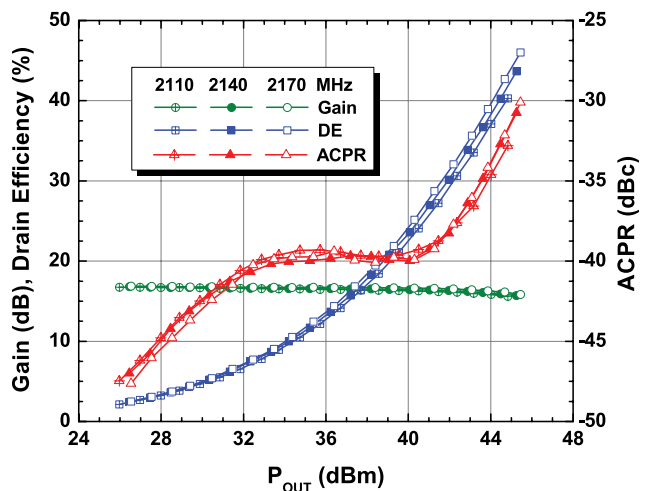

Figure 13 - Typical W-CDMA Performance in Load-Pull System, $V_{DS} = 28V$, $I_{DQ} = 600mA$, Frequency = 2110 to 2170MHz

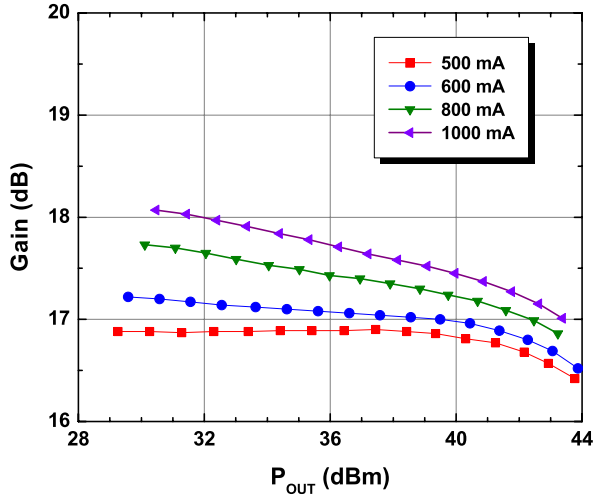

Figure 14 - OFDM performance in Nitronex Test Fixture as a Function of I_{DQ} , $V_{DS} = 28V$, $I_{DQ} = 500mA$ to $1000mA$, Frequency = $2500MHz$

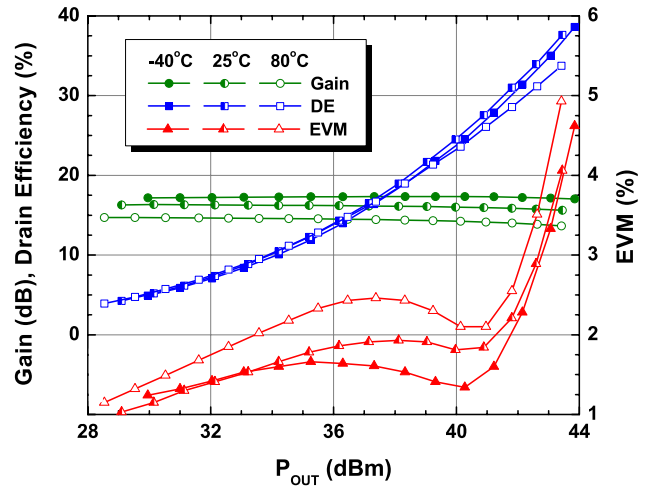

Figure 15 - OFDM performance in Nitronex Test Fixture as a Function of Case Temperature, $V_{DS} = 28V$, $I_{DQ} = 600mA$, Frequency = $2500MHz$

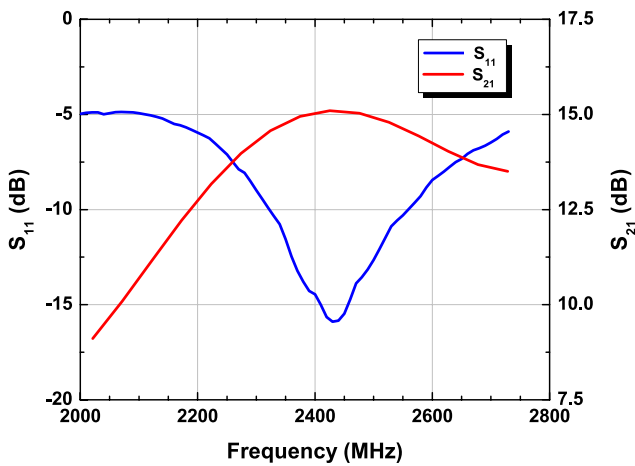

Figure 16 - S-parameters Measured in Nitronex Test Fixture, $V_{DS} = 28V$, $I_{DQ} = 600mA$

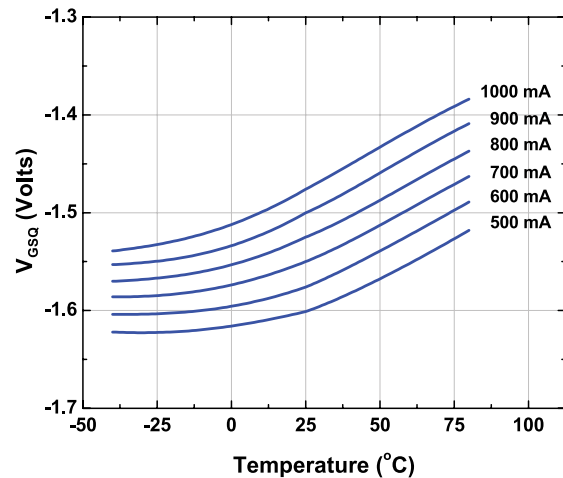

Figure 17 - Quiescent Gate Voltage (V_{GSQ}) Required to Reach I_{DQ} as a Function of Case Temperature, Measured in Nitronex Test Fixture at $V_{DS} = 28V$

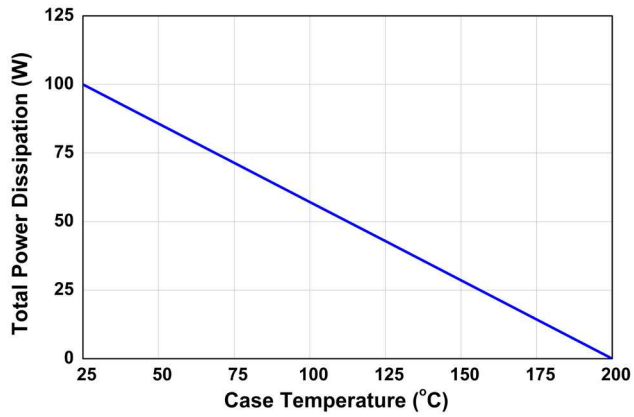

Figure 18 - Power Derating Curve

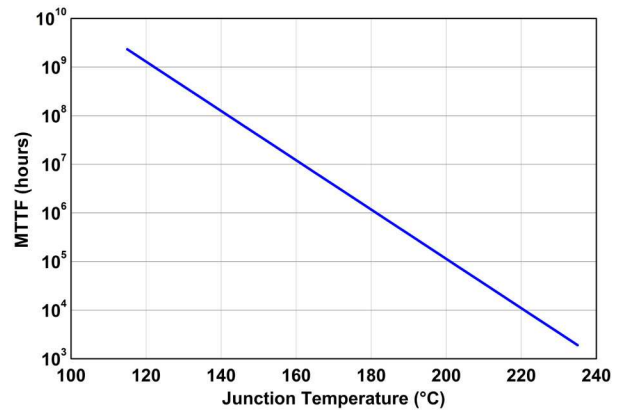

Figure 19 - MTTF of NRF1 Devices as a Function of Junction Temperature

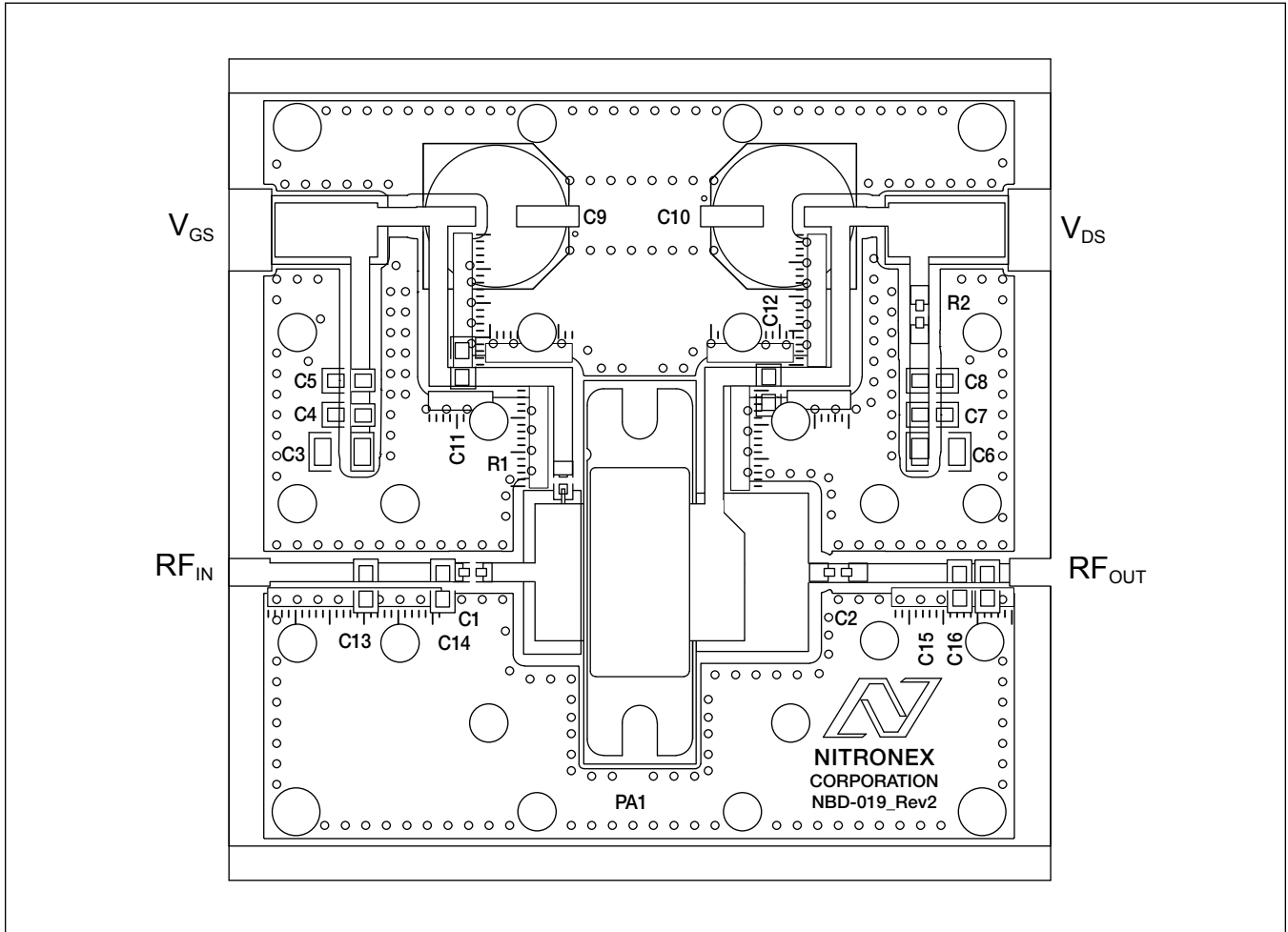

Figure 20 - APP-NPT25100-25 2500MHz Demonstration Board

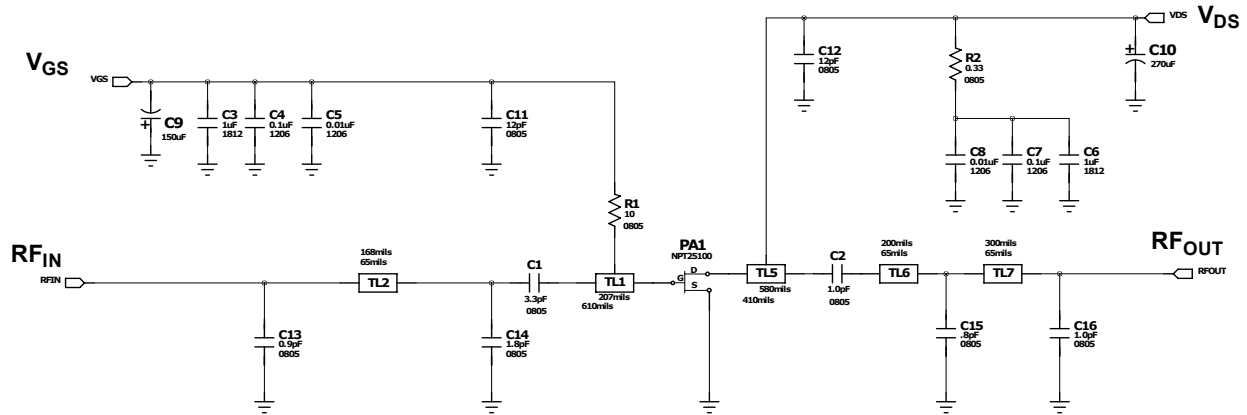

Figure 21 - APP-NPT25100-25 2500MHz Demonstration Board Equivalent Circuit

Table 2: APP-NPT25100-25 2500MHz Demonstration Board Bill of Materials

Name	Value	Tolerance	Vendor	Vendor Number
C1	3.3pF	+/- 0.1pF	ATC	ATC600F3R3B
C2	1.2pF	+/- 0.1pF	ATC	ATC100B1R2BT
C3	1uF	20%	Panasonic	ECJ-5YB2A105M
C4	0.1uF	10%	Kemet	C1206C104K1RACTU
C5	0.01uF	10%	AVX	12061C103KAT2A
C6	1uF	10%	Panasonic	ECJ-5YB2A105M
C7	0.1uF	10%	Kemet	C1206C104K1RACTU
C8	0.01uF	10%	AVX	12061C103KAT2A
C9	150uF	20%	Nichicon	UPW1C151MED
C10	270uF	20%	United Chmi-Con	ELXY630ELL271MK25S
C11	33pF	5%	ATC	ATC600F330B
C12	33pF	5%	ATC	ATC600F330B
C13	0.9pF	+/- 0.1pF	ATC	ATC600F0R9B
C14	1.8pF	+/- 0.1pF	ATC	ATC600F1R8B
C15	Do Not Place			
C16	0.8pF	+/- 0.1pF	ATC	ATC600F0R8B
PA1	--	--	--	NPT25100B
R1	10 ohm	1%	Panasonic	ERJ-6ENF10R0V
R2	0.033 ohm	1%	Panasonic	ERJ-6RQFR33V
NBD-019_Rev2	--	--	Alberta Printed Circuits	NBD-019_Rev2
Substrate			Rogers	R04350, t = 30mil $\epsilon_r = 3.5$

NPT25100



Ordering Information¹

Part Number	Description
NPT25100B	NPT25100 in AC780B-F2 Bolt-Down Package
NPT25100P	NPT25100 in AC780P-F2 Pill Package

1: To find a Nitronex contact in your area, visit our website at <http://www.nitronex.com>

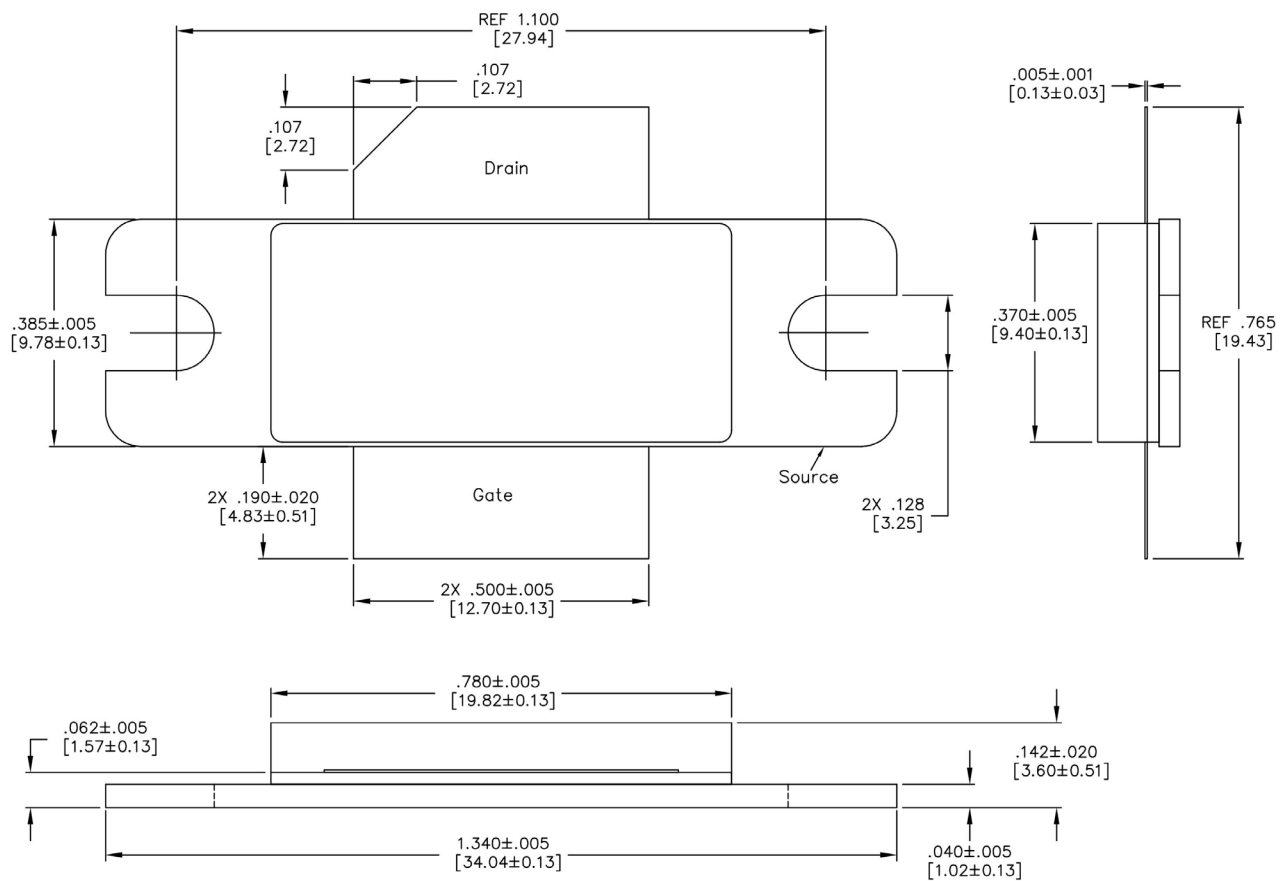

Figure 22 - AC780B-F2 Package Dimensions and Pinout (all dimensions are in inches)

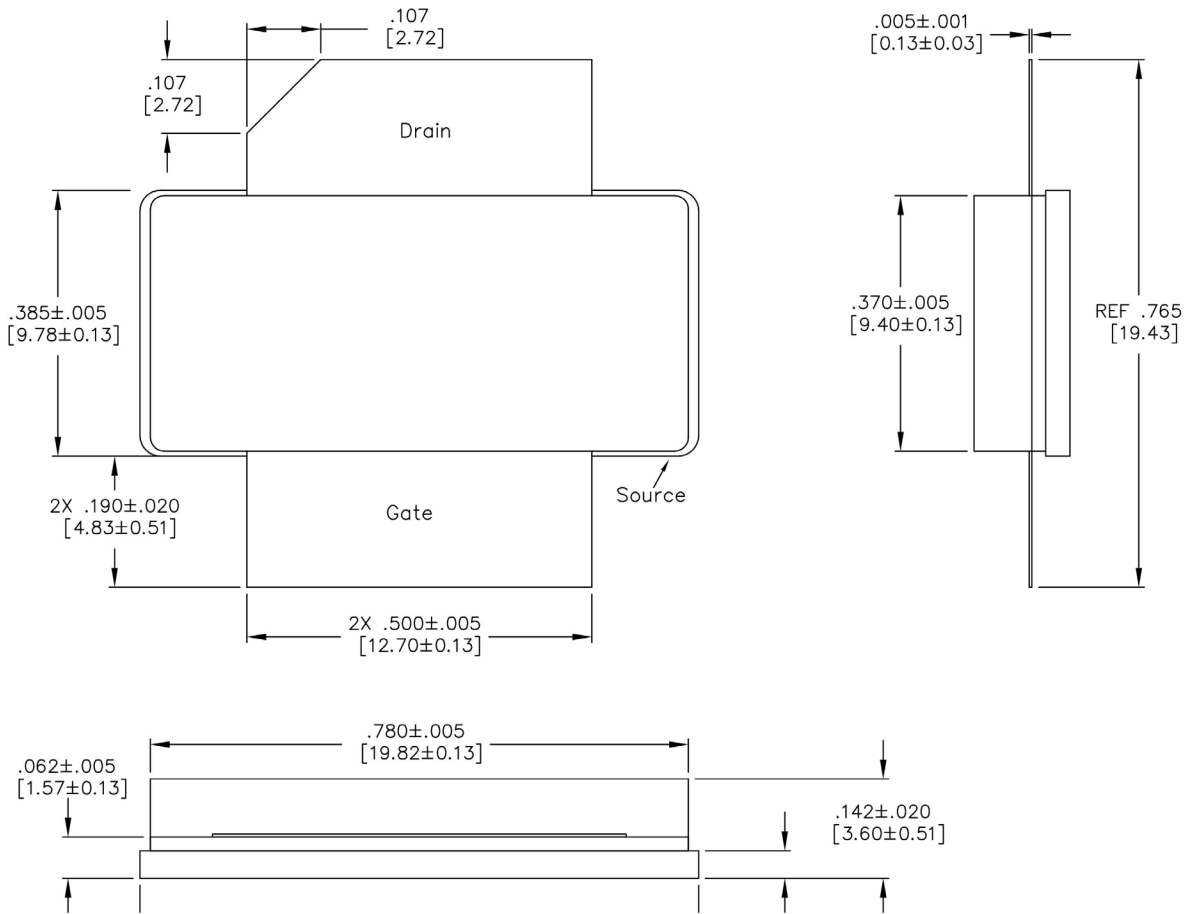

Figure 23 - AC780P-F2 Package Dimensions and Pinout (all dimensions are in inches)

Nitronex, LLC

2305 Presidential Drive
Durham, NC 27703 USA
+1.919.807.9100 (telephone)
+1.919.807.9200 (fax)
info@nitronex.com
www.nitronex.com

Additional Information

This part is lead-free and is compliant with the RoHS directive (Restrictions on the Use of Certain Hazardous Substances in Electrical and Electronic Equipment).

Important Notice

Nitronex, LLC reserves the right to make corrections, modifications, enhancements, improvements and other changes to its products and services at any time and to discontinue any product or service without notice. Customers should obtain the latest relevant information before placing orders and should verify that such information is current and complete. All products are sold subject to Nitronex terms and conditions of sale supplied at the time of order acknowledgment. The latest information from Nitronex can be found either by calling Nitronex at 1-919-807-9100 or visiting our website at www.nitronex.com.

Nitronex warrants performance of its packaged semiconductor or die to the specifications applicable at the time of sale in accordance with Nitronex standard warranty. Testing and other quality control techniques are used to the extent Nitronex deems necessary to support the warranty. Except where mandated by government requirements, testing of all parameters of each product is not necessarily performed.

Nitronex assumes no liability for applications assistance or customer product design. Customers are responsible for their product and applications using Nitronex semiconductor products or services. To minimize the risks associated with customer products and applications, customers should provide adequate design and operating safeguards.

Nitronex does not warrant or represent that any license, either express or implied, is granted under any Nitronex patent right, copyright, mask work right, or other Nitronex intellectual property right relating to any combination, machine or process in which Nitronex products or services are used.

Reproduction of information in Nitronex data sheets is permitted if and only if said reproduction does not alter any of the information and is accompanied by all associated warranties, conditions, limitations and notices. Any alteration of the contained information invalidates all warranties and Nitronex is not responsible or liable for any such statements.

Nitronex products are not intended or authorized for use in life support systems, including but not limited to surgical implants into the body or any other application intended to support or sustain life. Should Buyer purchase or use Nitronex, LLC products for any such unintended or unauthorized application, Buyer shall indemnify and hold Nitronex, LLC, its officers, employees, subsidiaries, affiliates, distributors, and its successors harmless against all claims, costs, damages, and expenses, and reasonable attorney fees arising out of, directly or indirectly, any claim of personal injury or death associated with such unintended or unauthorized use, notwithstanding if such claim alleges that Nitronex was negligent regarding the design or manufacture of said products.

Nitronex and the Nitronex logo are registered trademarks of Nitronex, LLC.
All other product or service names are the property of their respective owners.
©Nitronex, LLC 2012. All rights reserved.