

**FOUNDATION™ fieldbus
Backplane for the DPC system
DPC-49-4RMB/SY**

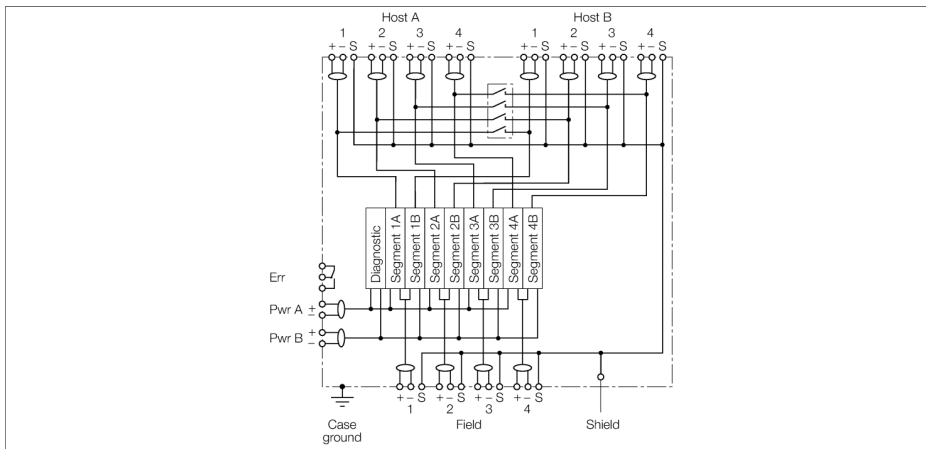

The DPC system (Diagnostic Power Conditioner) is a power supply system for the installation of FOUNDATION™ fieldbus H1 segments. It provides extensive diagnostic options for monitoring FOUNDATION™ fieldbus segments and thus supports plantwide asset management.

A DPC system consists of one or more module racks, each of which can take up to eight DPC-49-IPS1 power supply modules and one DPC-49-ADU or one DPC-49-DU diagnostic module. Up to four H1 segments per module rack can be operated and monitored redundantly in the FOUNDATION™ fieldbus network. The diagnostic data of the H1 segment can be transmitted via the HSE interface module DPC-49-HSEFD/24VDC to the higher level Asset Management System (only in conjunction with the diagnostic module DPC-49-ADU).

The module rack consist of a backplane and the actual rack system for the power supply modules and the diagnostics module.

The single components of the system are electrically linked via the connection terminals of the backplane. From electrical perspective, the backplane is to be considered passive.

The power can be supplied via two 2-pole screw connectors. The connection to the host system is provided via two system cables. Premoulded system cables are optionally available at TURCK.

For the connection of the H1 segments to the fieldbus side, each segment is individually connected with a removable 3-pole screw terminal.

The shielding is achieved via insulated shield bus or via the 3-pole screw terminal, which is internally connected with the M5 threaded bolt for equipotential bonding. A further M5 threaded bolt for equipotential bonding is simply connected to the housing.

For simple diagnostics processing, a connection is provided to the relay alarm contact of the diagnostics module.



- **Module rack for up to eight power supply modules and one diagnostic module for up to four redundant H1 segments.**
- **Redundant power supply**
- **Redundant HOST connection**
- **Removable terminal blocks with screw connections**
- **RJ45 connector for HSE fieldbus diagnostics**

FOUNDATION™ fieldbus
Backplane for the DPC system
DPC-49-4RMB/SY

TURCK

Industrial
Automation

Type code	DPC-49-4RMB/SY
Ident no.	6882025
Operating voltage range	18...32 VDC
Surge protection	> 250 VDC
Electrical connection	removable terminal block, reverse polarity protected, screw connection RJ45 socket
Protection class	IP20
MTTF	115 years acc. to SN 29500 (Ed. 99) 40 °C
Ambient temperature	-20...+60 °C
Housing material	Aluminium
Housing color	black/yellow
Dimensions	220x 210x 113 mm
Connection mode	snap-fit on DIN rail (DIN 60715)

Dimensions

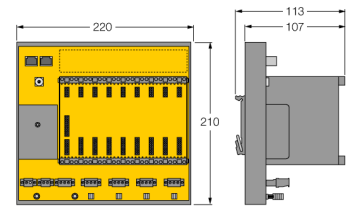

FOUNDATION™ fieldbus
Backplane for the DPC system
DPC-49-4RMB/SY

TURCK

Industrial
Automation

Accessories

Type code	Ident no.	Description	Dimension drawing
BM-DPC	6882015	blind module for unused slots	