

BL67 base module
M8 connectors
BL67-B-8M8-4-P

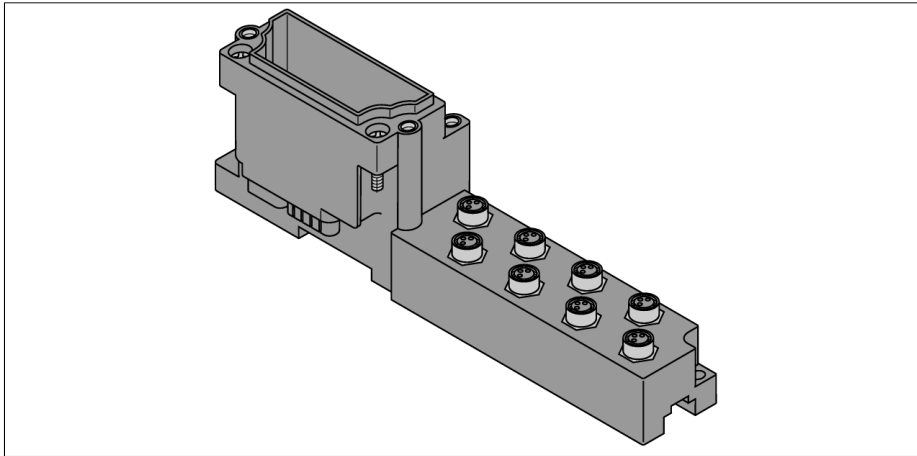

- Passive connection components for sensors and actuators
- Quick replacement of electronics in wired state
- Mechanical coding prevents accidental plugging of the wrong electronic module
- Protection class IP67
- M8 connection technology
- 4-pin

Functional principle

The pin resp. signal assignment results from the combination with an electronic module. You find the pin configuration and the wiring diagrams on the data sheet of the corresponding electronic module.

BL67 base modules are connected to the right of the gateway, using two screws for each module. A DIN rail is not required. This way, a compact and stable unit is built. The unit can now be mounted on a DIN rail or directly on the machine.

The field devices are connected to the base modules which are available with different connection technology (M8, M12, M23 and 7/8").

Note

Further technical data like temperature range are determined by the electronic modules and can be found on the data sheets.

Type code	BL67-B-8M8-4-P
Ident no.	6827384
Housing material	Polycarbonate, flame resistance (PC V0)
Housing color	Slate grey (RAL 7015)
Tightening torque fixing screw	0.9...1.2 Nm
DIN rail mounting	yes, Attention: Offset
Direct mounting	Two mounting holes, 6 mm Ø
Number of pins	4